

SAC-5P-MINMS/ 2,0-U40 - Bus system cable



1416681

<https://www.phoenixcontact.com/us/products/1416681>

Please be informed that the data shown in this PDF document is generated from our online catalog. Please find the complete data in the user documentation. Our general terms of use for downloads are valid.



Bus system cable, DeviceNet™, 5-position, Plug straight 7/8"-16UNF, on free cable end, cable length: 2 m

Commercial data

Item number	1416681
Packing unit	1 pc
Note	Made to order (non-returnable)
Sales key	BF14
Product key	BF1IMD
GTIN	4055626219363
Weight per piece (including packing)	436.1 g
Weight per piece (excluding packing)	418.7 g
Customs tariff number	85444290
Country of origin	MX

SAC-5P-MINMS/ 2,0-U40 - Bus system cable



1416681

<https://www.phoenixcontact.com/us/products/1416681>

Technical data

Notes

Trade restriction

CE note	The products are offered exclusively for export outside the EU and the European Economic Area.
---------	--

Product properties

Product type	Sensor/actuator cable
Sensor type	DeviceNet™
Number of positions	5
Application	Standard
Shielded	yes
Coding	A

Material specifications

Flammability rating according to UL 94	V-0
Material of grip body	PVC
Contact material	CuZn
Contact surface material	Au
Contact carrier material	PVC
Material for screw connection	Anodized aluminum

Electrical properties

Contact resistance	≤ 5 mΩ
Insulation resistance	≥ 100 MΩ
Nominal voltage U_N	300 V AC
	300 V DC
Nominal current I_N	8 A
Protective circuit	unwired

Signaling

Status display	No
Status display present	No

Connection data

Conductor connection

Tightening torque	10 lb _F -in.
	1.12 Nm

Pin assignment

Contact Color (signal designation) Contact (optional)	1 (Plug) SR (shield) 1
	2 (Plug) RD (V+) 2
	3 (Plug) BK (V-) 3

SAC-5P-MINMS/ 2,0-U40 - Bus system cable



1416681

<https://www.phoenixcontact.com/us/products/1416681>

	4 (Plug) WH (CAN_H) 4
	5 (Plug) BU (CAN_L) 5

Connector

Connection 1

Type	Plug straight 7/8"-16UNF
------	--------------------------

Connection 2

Type	free cable end
------	----------------

Cable/line

Cable length	2 m
--------------	-----

DeviceNet trunk cable [U40]

Number of positions	5
Shielded	yes
Cable type	DeviceNet trunk cable [U40]
Conductor structure signal line	19 x AWG 30
Conductor cross section	2 x AWG 18 data cable 2 x AWG 15 power supply 1 x AWG 18 drain wire
External cable diameter	11.43 mm
Outer sheath, material	PVC
External sheath, color	gray
Conductor material	Tin-plated Cu litz wires
Material wire insulation	Foamed PE PVC (Power supply)
Single wire, color	red-black, blue-white
Twisted pairs	2 cores to the pair
Type of pair shielding	Plastic-coated aluminum foil, aluminum side outside
Overall twist	2 pairs around a drain wire in the center to the core
Optical shield covering	65 %
Flame resistance	UL 1581, FT4
Resistance to oil	OIL RES I according to UL 2256
Other resistance	UV resistant (720 h) (UL 2556)
Ambient temperature (operation)	-20 °C ... 75 °C (cable, fixed installation) -5 °C ... 80 °C (Cable, flexible installation)

Environmental and real-life conditions

Ambient conditions

Degree of protection	IP68
Ambient temperature (operation)	-20 °C ... 75 °C (Plug / socket) -20 °C ... 75 °C (cable, fixed installation) -5 °C ... 80 °C (Cable, flexible installation)

SAC-5P-MINMS/ 2,0-U40 - Bus system cable



1416681

<https://www.phoenixcontact.com/us/products/1416681>

Standards and regulations

Other resistance

UL 2556

SAC-5P-MINMS/ 2,0-U40 - Bus system cable



1416681

<https://www.phoenixcontact.com/us/products/1416681>

Drawings

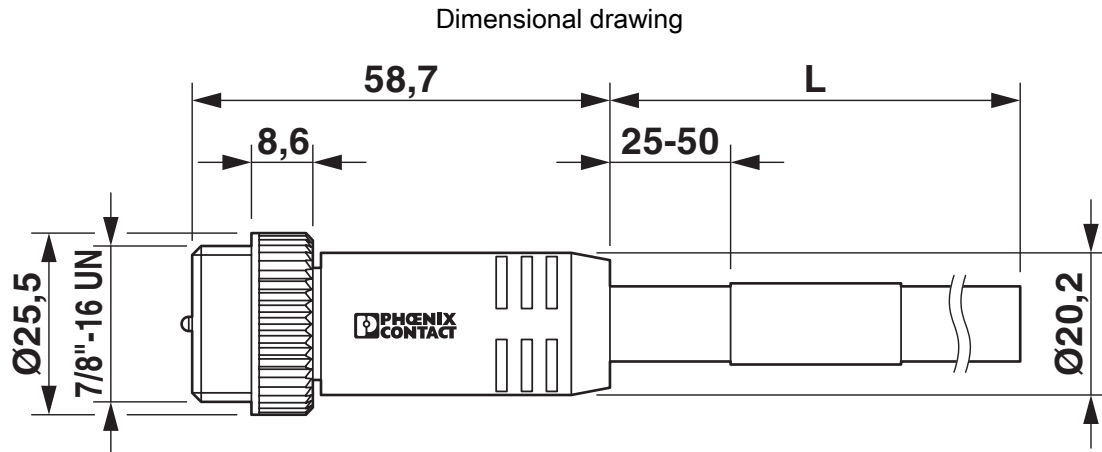

7/8"-16UNF plug, straight

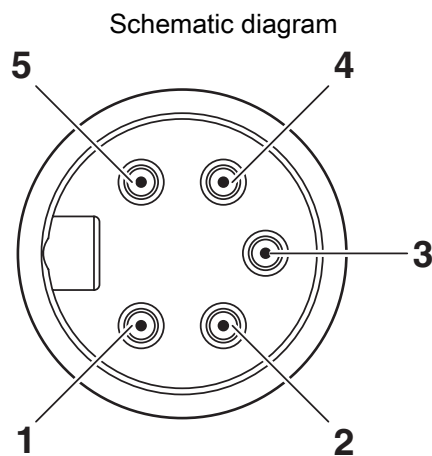

Pin assignment, plug, 7/8"-16UNF, 5-pos., view of male side

SAC-5P-MINMS/ 2,0-U40 - Bus system cable



1416681

<https://www.phoenixcontact.com/us/products/1416681>

Circuit diagram

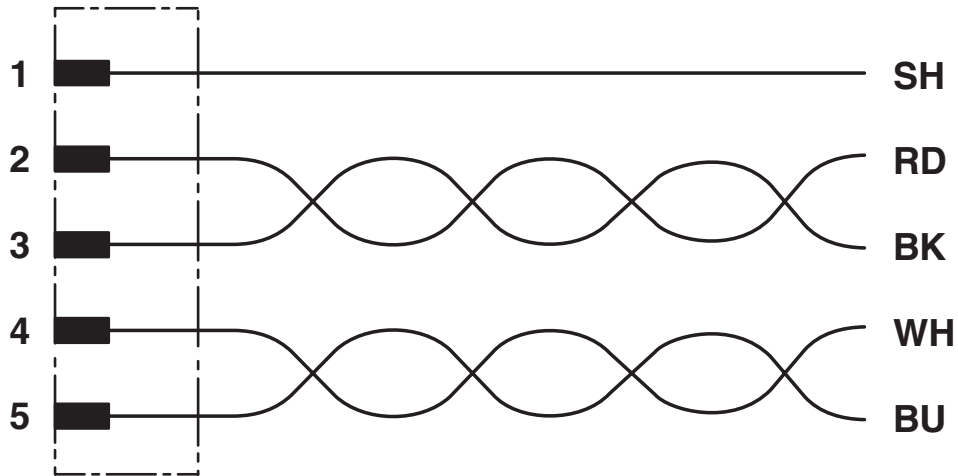

SAC-5P-MINMS/ 2,0-U40 - Bus system cable



1416681

<https://www.phoenixcontact.com/us/products/1416681>

Approvals

🔗 To download certificates, visit the product detail page: <https://www.phoenixcontact.com/us/products/1416681>



UL Listed

Approval ID: FILE E 221474



cUL Listed

Approval ID: FILE E 221474

cULus Listed

SAC-5P-MINMS/ 2,0-U40 - Bus system cable



1416681

<https://www.phoenixcontact.com/us/products/1416681>

Classifications

ECLASS

ECLASS-11.0	27060307
ECLASS-12.0	27060307
ECLASS-13.0	27060307

UNSPSC

UNSPSC 21.0	31251501
-------------	----------

SAC-5P-MINMS/ 2,0-U40 - Bus system cable



1416681

<https://www.phoenixcontact.com/us/products/1416681>

Environmental product compliance

China RoHS	Environmentally friendly use period: unlimited = EFUP-e No hazardous substances above threshold values
------------	---

Phoenix Contact 2024 © - all rights reserved
<https://www.phoenixcontact.com>

Phoenix Contact USA
586 Fulling Mill Road
Middletown, PA 17057, United States
(+717) 944-1300
info@phoenixcon.com