



Figure similar

Non-reversing motor starter, Size 1, Three phase full voltage, Amb compensate bimetal OLrelay Contactor amp rating 27Amp 380 440/440 480V 50/60HZ coil, Non-combination type, Enclosure type (open), No enclosure

product brand name	Class 14 & 22
design of the product	Full-voltage non-reversing motor starter

General technical data

weight [lb]	3.5 lb
Height x Width x Depth [in]	7.45 × 5.75 × 3.89 in
touch protection against electrical shock	Not finger-safe
installation altitude [ft] at height above sea level maximum	6560 ft
ambient temperature [°F]	
• during storage	-22 ... +149 °F
• during operation	-4 ... +104 °F
ambient temperature	
• during storage	-30 ... +65 °C
• during operation	-20 ... +40 °C
country of origin	Mexico

Horsepower ratings

yielded mechanical performance [hp] for 3-phase AC motor	
• at 200/208 V rated value	7.5 hp
• at 220/230 V rated value	7.5 hp
• at 460/480 V rated value	10 hp
• at 575/600 V rated value	10 hp

Contactors

size of contactor	NEMA controller size 1
number of NO contacts for main contacts	3
operating voltage for main current circuit at AC at 60 Hz maximum	600 V
operational current at AC at 600 V rated value	27 A
mechanical service life (operating cycles) of the main contacts typical	10000000

Auxiliary contact

number of NC contacts at contactor for auxiliary contacts	0
number of NO contacts at contactor for auxiliary contacts	1
number of total auxiliary contacts maximum	8
contact rating of auxiliary contacts of contactor according to UL	10A@600VAC (A600), 5A@600VDC (P600)

Coil

type of voltage of the control supply voltage	AC
control supply voltage	
• at AC at 50 Hz rated value	380 ... 440 V
• at AC at 60 Hz rated value	440 ... 480 V
holding power at AC minimum	8.6 W

apparent pick-up power of magnet coil at AC	218 VA
apparent holding power of magnet coil at AC	25 VA
operating range factor control supply voltage rated value of magnet coil	0.85 ... 1.1
percentual drop-out voltage of magnet coil related to the input voltage	50 %
ON-delay time	19 ... 29 ms
OFF-delay time	10 ... 24 ms

Overload relay

product function	Yes
<ul style="list-style-type: none"> • overload protection 	Yes
<ul style="list-style-type: none"> • test function 	No
<ul style="list-style-type: none"> • external reset 	Manual and automatic
reset function	0.85 ... 1.15
adjustment range of thermal overload trip unit	1
number of NC contacts of auxiliary contacts of overload relay	0
number of NO contacts of auxiliary contacts of overload relay	
operational current of auxiliary contacts of overload relay	
<ul style="list-style-type: none"> • at AC at 600 V 	10 A
<ul style="list-style-type: none"> • at DC at 250 V 	5 A
contact rating of auxiliary contacts of overload relay according to UL	10A@600VAC (A600), 5A@250VDC (P300)

Enclosure

degree of protection NEMA rating	Open device (no enclosure)
design of the housing	NA

Mounting/wiring

mounting position	Vertical
fastening method	Surface mounting and installation
type of electrical connection for supply voltage line-side	Screw-type terminals
tightening torque [lbf-in] for supply	35 ... 35 lbf-in
temperature of the conductor for supply maximum permissible	75 °C
material of the conductor for supply	AL or CU
type of electrical connection for load-side outgoing feeder	Screw-type terminals
tightening torque [lbf-in] for load-side outgoing feeder	35 ... 50 lbf-in
type of electrical connection of magnet coil	Screw-type terminals
tightening torque [lbf-in] at magnet coil	5 ... 12 lbf-in
type of connectable conductor cross-sections of magnet coil at AWG cables single or multi-stranded	2x (16 ... 12 AWG)
temperature of the conductor at magnet coil maximum permissible	75 °C
material of the conductor at magnet coil	CU
type of electrical connection for auxiliary contacts	Screw-type terminals
tightening torque [lbf-in] at contactor for auxiliary contacts	10 ... 15 lbf-in
type of connectable conductor cross-sections at contactor at AWG cables for auxiliary contacts single or multi-stranded	1x (12 AWG), 2x (16 ... 14 AWG), 2x (18 ... 16 AWG)
temperature of the conductor at contactor for auxiliary contacts maximum permissible	75 °C
material of the conductor at contactor for auxiliary contacts	CU
type of electrical connection at overload relay for auxiliary contacts	Screw-type terminals
tightening torque [lbf-in] at overload relay for auxiliary contacts	5 ... 12 lbf-in
type of connectable conductor cross-sections at overload relay at AWG cables for auxiliary contacts single or multi-stranded	2x (16 ... 12 AWG)
temperature of the conductor at overload relay for auxiliary contacts maximum permissible	75 °C
material of the conductor at overload relay for auxiliary contacts	CU

Short-circuit current rating

design of the fuse link for short-circuit protection of the main circuit required	10kA@600V (Class H or K); 100kA@600V (Class R or J)
---	---

design of the short-circuit trip
 maximum short-circuit current breaking capacity (Icu)

- at 240 V
- at 480 V
- at 600 V

certificate of suitability

Thermal magnetic circuit breaker

14 kA
 10 kA
 10 kA

NEMA ICS 2; UL 508; CSA 22.2, No.14

Further information

Industrial Controls - Product Overview (Catalogs, Brochures,...)

www.usa.siemens.com/iccatalog

Industry Mall (Online ordering system)

<https://mall.industry.siemens.com/mall/en/us/Catalog/product?mfb=US2:14DP32AH81>

Service&Support (Manuals, Certificates, Characteristics, FAQs,...)

<https://support.industry.siemens.com/cs/US/en/ps/US2:14DP32AH81>

Image database (product images, 2D dimension drawings, 3D models, device circuit diagrams, EPLAN macros, ...)

http://www.automation.siemens.com/bilddb/cax_de.aspx?mfb=US2:14DP32AH81&lang=en

Certificates/approvals

<https://support.industry.siemens.com/cs/US/en/ps/US2:14DP32AH81/certificate>

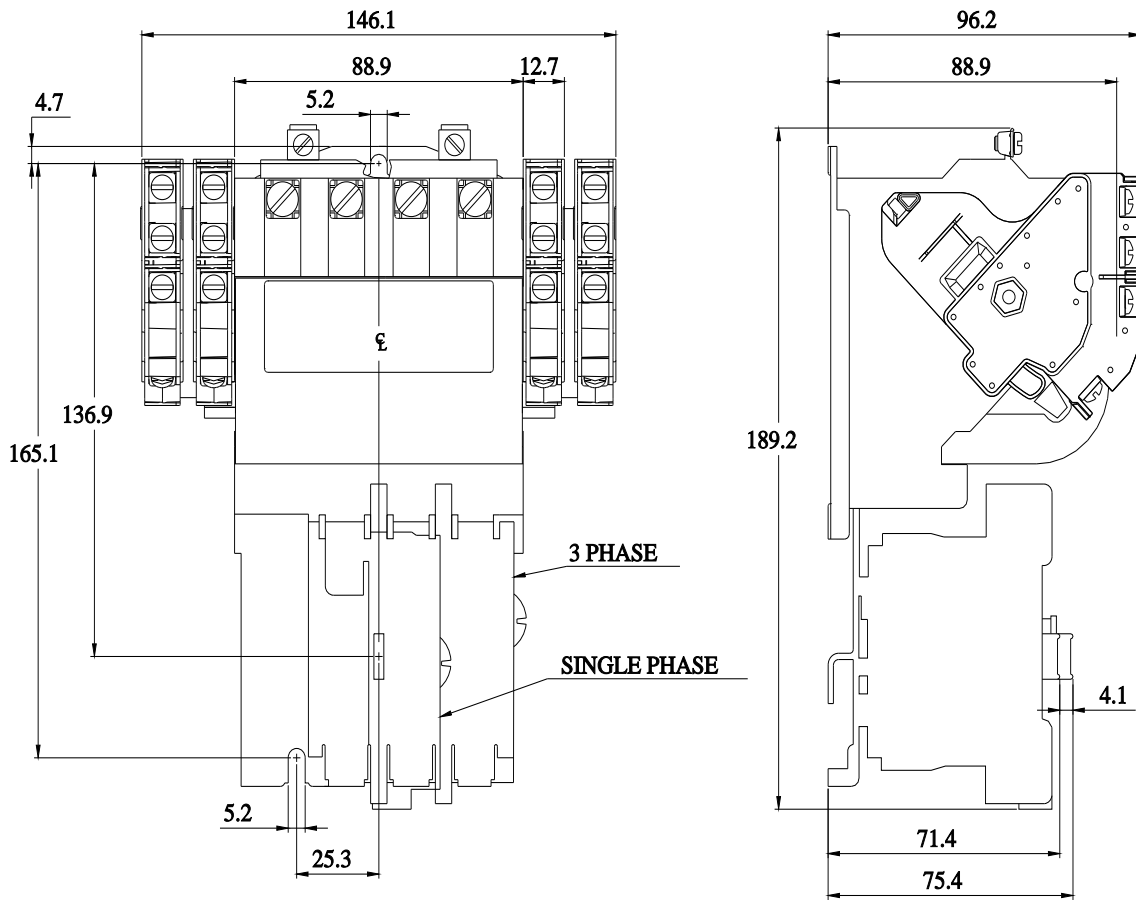

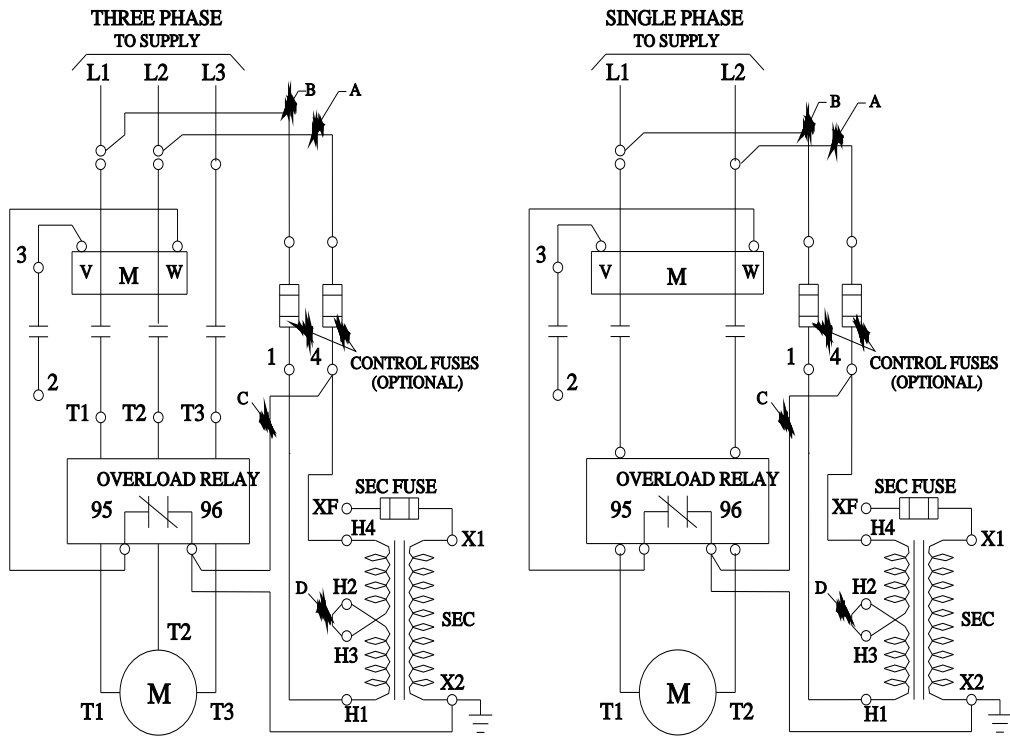

D46590001

last modified:

4/27/2021 