

QPD CW 3PE2,5 2X9-14 BK - Conductor connectors



1582539

<https://www.phoenixcontact.com/us/products/1582539>

Please be informed that the data shown in this PDF document is generated from our online catalog. Please find the complete data in the user documentation. Our general terms of use for downloads are valid.



Cable connector panel feed-through, two-sided with QPD nut, black, 3+ PE pos., 1.0 mm² ... 2.5 mm²/630 V/20 A, for cable diameters of 9 mm ... 14 mm.

Your advantages

- Innovative and time saving - QUICKON fast connection for time saving of up to 80 % for on-site connection
- Robust throughout: housing with IP68/IP69K and IK07 protection for a wide range of applications
- Safer connection with mechanical coding to protect against mismatching, and touch-proof protection in accordance with DIN EN 0105
- Easy and safe - with the cable connector, you can repair or extend cables quickly, in combination with the connector as well as the coupling connection

Commercial data

Item number	1582539
Packing unit	1 pc
Note	Made to order (non-returnable)
Sales key	BF50
Product key	BF6CBB
Catalog page	Page 384 (C-4-2013)
GTIN	4046356552479
Weight per piece (including packing)	73.3 g
Weight per piece (excluding packing)	73.3 g
Customs tariff number	85366990
Country of origin	DE

QPD CW 3PE2,5 2X9-14 BK - Conductor connectors



1582539

<https://www.phoenixcontact.com/us/products/1582539>

Technical data

Product properties

Product type	Panel feed-through
Product family	QPD
Type	QPD 4x2,5
Number of positions	4
Connection profile	3+PE
Position marking	1, 2, 3, PE
Number of connections	10
Number of connections per position	1
Coding	Coding profile

Insulation characteristics

Overvoltage category	III
Degree of pollution	3

Connection data

Connection technology

Connection method On the device side	IDC connection
Frequency of connections between conductors of the same cross section	max. 10

Conductor connection

Conductor cross section flexibel	1 mm ² ... 2.5 mm ²
Conductor cross section solid	1 mm ² ... 2.5 mm ²
Connection cross section AWG	16 ... 14
Tightening torque Union nut	5 Nm
Tightening torque Locking nut	5 Nm
Wrench size Union nut	22 mm
Wrench size Locking nut	27 mm

Dimensions

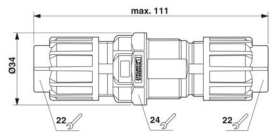
Dimensional drawing	
Width	34 mm
Height	34 mm
Length	111 mm
Diameter	34 mm

Electrical properties

QPD CW 3PE2,5 2X9-14 BK - Conductor connectors



1582539

<https://www.phoenixcontact.com/us/products/1582539>

Rated surge voltage (II/2)	8 kV
Rated surge voltage (III/2)	8 kV
Rated surge voltage (III/3)	6 kV
Rated current	20 A
Contact resistance	< 3 mΩ
rated voltage (II/2)	1000 V
rated voltage (III/2)	1000 V
Rated voltage (III/3)	690 V
Nominal voltage U_N	690 V
Nominal current I_N	20 A

Mechanical properties

Mechanical data

Insertion/withdrawal cycles	max. 50
-----------------------------	---------

Material specifications

Color	black (RAL 9005)
Material Housing	PA
Material Contact	Cu
Material Contact surface	Silver-plated
Flammability rating according to UL 94	V0
Material wire insulation	PVC / PE / rubber / TPE

Cable/line

Structure of individual litz in acc. with VDE 0295 / smallest wire diameter	VDE 0295 class 1 to 6/min. 0.15 mm
External cable diameter	6 mm ... 10 mm (Order Quickon nuts or Quickon connectors separately)
Wire diameter including insulation	2 mm ... 3.8 mm
Position marking	1, 2, 3, PE
Material wire insulation	PVC / PE / rubber / TPE
Halogen-free	no

Environmental and real-life conditions

Ambient conditions

Degree of protection	IP66
	IP68 (2 m / 24 h)
	IP69K
Ambient temperature (operation)	-40 °C ... 100 °C
Temperature when conductor connected	-5 °C ... 50 °C
Ambient temperature (storage/transport)	-40 °C ... 100 °C

QPD CW 3PE2,5 2X9-14 BK - Conductor connectors

1582539

<https://www.phoenixcontact.com/us/products/1582539>



Phoenix Contact 2024 © - all rights reserved

<https://www.phoenixcontact.com>

Phoenix Contact USA
586 Fulling Mill Road
Middletown, PA 17057, United States
(+717) 944-1300
info@phoenixcon.com