

# SPT 16/ 1-H-10,0 - PCB terminal block



1735778

<https://www.phoenixcontact.com/pc/products/1735778>

Please be informed that the data shown in this PDF document is generated from our online catalog. Please find the complete data in the user documentation. Our general terms of use for downloads are valid.



PCB terminal block, nominal current: 76 A, rated voltage (III/2): 1000 V, nominal cross section: 16 mm<sup>2</sup>, number of potentials: 1, number of rows: 1, number of positions per row: 1, product range: SPT 16/..-H, pitch: 10 mm, connection method: Push-in spring connection, mounting: Wave soldering, conductor/PCB connection direction: 0 °, color: green, Pin layout: Linear pinning, Solder pin [P]: 4 mm, number of solder pins per potential: 6, type of packaging: packed in cardboard

## Your advantages

- Time saving push-in connection, tools not required
- Defined contact force ensures that contact remains stable over the long term
- Clamping space opened by means of fixed screwdriver enables convenient conductor connection
- Operation and conductor connection from one direction enable integration into front of device

## Commercial data

Item number	1735778
Packing unit	50 pc
Minimum order quantity	1 pc
Product key	AAOBCA
Catalog page	Page 467 (C-1-2013)
GTIN	4046356179416
Weight per piece (including packing)	9.452 g
Weight per piece (excluding packing)	9.432 g
Customs tariff number	85369010
Country of origin	BG

# SPT 16/ 1-H-10,0 - PCB terminal block



1735778

<https://www.phoenixcontact.com/pc/products/1735778>

## Technical data

### Product properties

Product type	Printed circuit board terminal
Product family	SPT 16/...-H
Product line	COMBICON Terminals XL
Type	PC terminal block can be aligned
Number of positions	1
Pitch	10 mm
Number of connections	1
Number of rows	1
Number of potentials	1
Pin layout	Linear pinning
Solder pins per potential	6

### Electrical properties

Nominal current $I_N$	76 A
Nominal voltage $U_N$	1000 V
Degree of pollution	3
Rated voltage (III/3)	1000 V
Rated surge voltage (III/3)	8 kV
Rated voltage (III/2)	1000 V
Rated surge voltage (III/2)	8 kV
Rated voltage (II/2)	1000 V
Rated surge voltage (II/2)	6 kV

### Connection data

#### Connection technology

Type	PC terminal block can be aligned
Nominal cross section	16 mm <sup>2</sup>

#### Conductor connection

Connection method	Push-in spring connection
Conductor cross section rigid	0.75 mm <sup>2</sup> ... 16 mm <sup>2</sup>
Conductor cross section flexible	0.75 mm <sup>2</sup> ... 16 mm <sup>2</sup>
Conductor cross section AWG	20 ... 4
Conductor cross section flexible, with ferrule without plastic sleeve	0.75 mm <sup>2</sup> ... 16 mm <sup>2</sup>
Conductor cross section, flexible, with ferrule, with plastic sleeve	0.75 mm <sup>2</sup> ... 10 mm <sup>2</sup>
2 conductors with the same cross section, flexible, with TWIN ferrule with plastic sleeve	0.75 mm <sup>2</sup> ... 4 mm <sup>2</sup>
Stripping length	18 mm

## Mounting

# SPT 16/ 1-H-10,0 - PCB terminal block



1735778

<https://www.phoenixcontact.com/pc/products/1735778>

Mounting type	Wave soldering
Pin layout	Linear pinning

## Material specifications

### Material data - contact

Note	WEEE/RoHS-compliant, free of whiskers according to IEC 60068-2-82/JEDEC JESD 201
Contact material	Cu alloy
Surface characteristics	Tin-plated
Metal surface terminal point (top layer)	Tin (10 - 16 µm Sn)
Metal surface soldering area (top layer)	Tin (10 - 16 µm Sn)

### Material data - housing

Color (Housing)	green (6021)
Insulating material	PA
Insulating material group	I
CTI according to IEC 60112	600
Flammability rating according to UL 94	V0
Glow wire flammability index GWFI according to EN 60695-2-12	850
Glow wire ignition temperature GWIT according to EN 60695-2-13	775
Temperature for the ball pressure test according to EN 60695-10-2	125 °C

## Notes

Notes on operation	The single-position PCB terminal block can be used for voltages up to 1500 V (DC) and 1000 V (AC). The relevant device standard and the appropriate required air clearances and creepage distances should be observed following installation
--------------------	--

## Dimensions

Dimensional drawing	
Pitch	10 mm
Width [w]	11.8 mm
Height [h]	34 mm
Length [l]	29 mm
Installed height	30 mm
Solder pin length [P]	4 mm
Pin dimensions	1 x 1.2 mm

### PCB design

Pin spacing	15 mm
-------------	-------

# SPT 16/ 1-H-10,0 - PCB terminal block



1735778

<https://www.phoenixcontact.com/pc/products/1735778>

Hole diameter	1.7 mm
---------------	--------

## Electrical tests

### Air clearances and creepage distances |

Insulating material group	I
Rated insulation voltage (III/3)	1000 V
Rated surge voltage (III/3)	8 kV
Rated insulation voltage (III/2)	1000 V
Rated surge voltage (III/2)	8 kV
Rated insulation voltage (II/2)	1000 V
Rated surge voltage (II/2)	6 kV

## Packaging specifications

Type of packaging	packed in cardboard
-------------------	---------------------

# SPT 16/ 1-H-10,0 - PCB terminal block

1735778

<https://www.phoenixcontact.com/pc/products/1735778>



## Drawings

Dimensional drawing

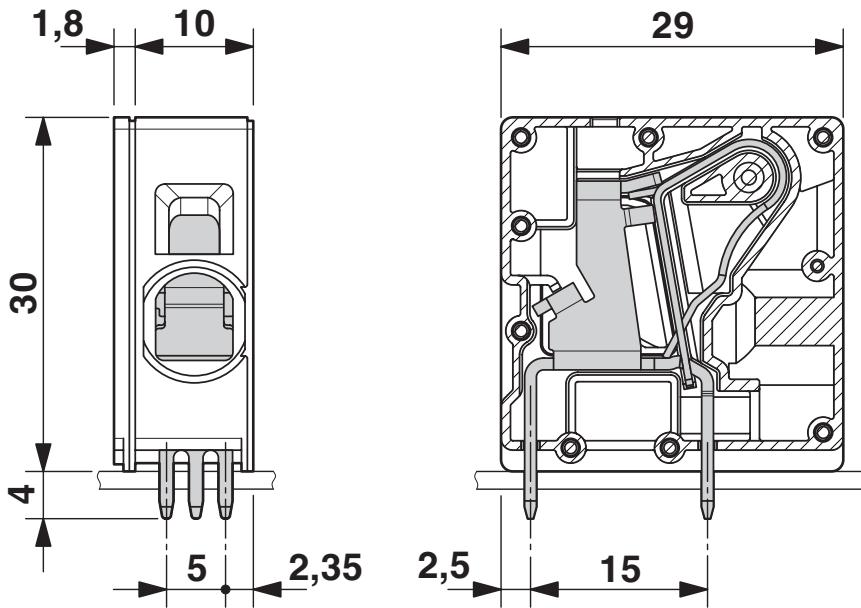

Drilling plan/solder pad geometry

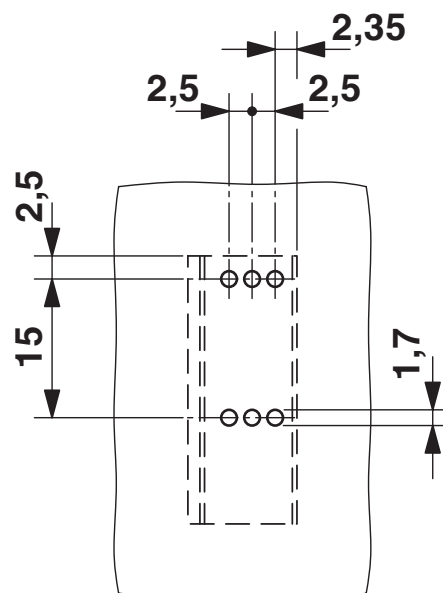

# SPT 16/ 1-H-10,0 - PCB terminal block



1735778

<https://www.phoenixcontact.com/pc/products/1735778>

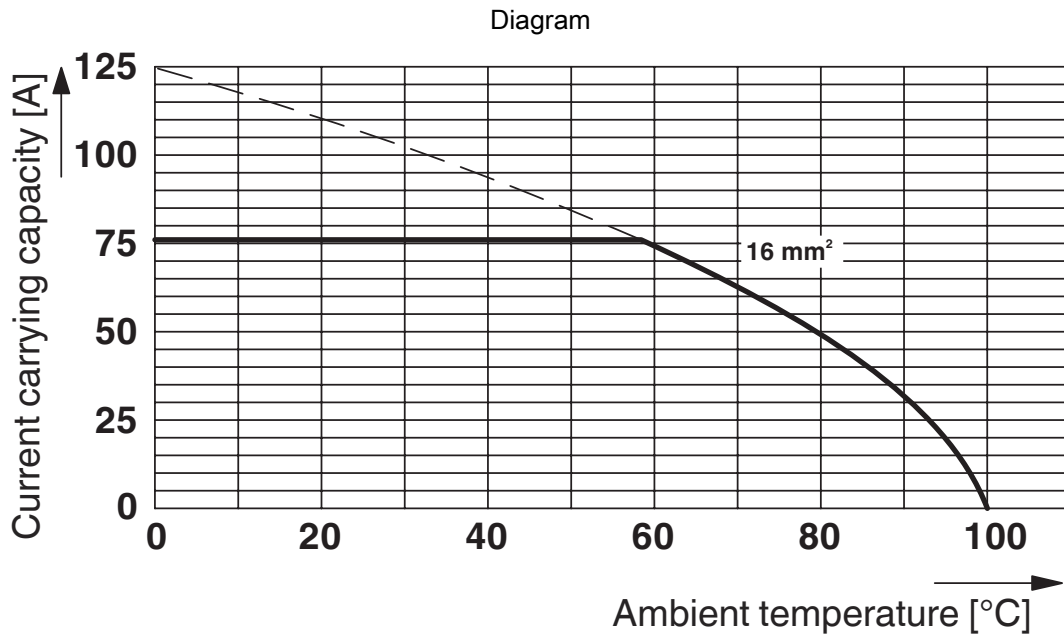

Type: SPT 16/...-H-10,0-ZB

Test based on DIN EN 60512-5-2:2003-01

Reduction factor = 1

Number of positions: 5

# SPT 16/ 1-H-10,0 - PCB terminal block



1735778

<https://www.phoenixcontact.com/pc/products/1735778>

## Approvals

To download certificates, visit the product detail page: <https://www.phoenixcontact.com/pc/products/1735778>

 <b>cULus Recognized</b> Approval ID: E60425-20061129				
	Nominal voltage $U_N$	Nominal current $I_N$	Cross section AWG	Cross section $\text{mm}^2$
Use group B	300 V	66 A	20 - 4	-
Use group C	150 V	66 A	20 - 4	-
Use group D	300 V	10 A	20 - 4	-

 <b>VDE Zeichengenehmigung</b> Approval ID: 40042909				
	Nominal voltage $U_N$	Nominal current $I_N$	Cross section AWG	Cross section $\text{mm}^2$
	1000 V	76 A	-	0.75 - 16

# SPT 16/ 1-H-10,0 - PCB terminal block



1735778

<https://www.phoenixcontact.com/pc/products/1735778>

## Classifications

### ECLASS

ECLASS-11.0	27460101
ECLASS-12.0	27460101
ECLASS-13.0	27460101

### ETIM

ETIM 9.0	EC002643
----------	----------

### UNSPSC

UNSPSC 21.0	39121400
-------------	----------

# SPT 16/ 1-H-10,0 - PCB terminal block



1735778

<https://www.phoenixcontact.com/pc/products/1735778>

## Environmental product compliance

### EU RoHS

Fulfills EU RoHS substance requirements	Yes, No exemptions
---	--------------------

### China RoHS

Environment friendly use period (EFUP)	EFUP-E
	No hazardous substances above the limits

### EU REACH SVHC

REACH candidate substance (CAS No.)	No substance above 0.1 wt%
-------------------------------------	----------------------------

Phoenix Contact 2024 © - all rights reserved  
<https://www.phoenixcontact.com>

PHOENIX CONTACT GmbH & Co. KG  
Flachmarktstraße 8  
D-32825 Blomberg  
+49 (0) 5235-3 00  
[info@phoenixcontact.com](mailto:info@phoenixcontact.com)