

SPT 16/ 8-H-10,0-ZB - PCB terminal block



1735846

<https://www.phoenixcontact.com/za/products/1735846>

Please be informed that the data shown in this PDF document is generated from our online catalog. Please find the complete data in the user documentation. Our general terms of use for downloads are valid.



PCB terminal block, nominal current: 76 A, rated voltage (III/2): 1000 V, nominal cross section: 16 mm², number of potentials: 8, number of rows: 1, number of positions per row: 8, product range: SPT 16/...-H, pitch: 10 mm, connection method: Push-in spring connection, mounting: Wave soldering, conductor/PCB connection direction: 0 °, color: green, Pin layout: Zigzag pinning W, Solder pin [P]: 4 mm, number of solder pins per potential: 3, type of packaging: packed in cardboard

Your advantages

- Time saving push-in connection, tools not required
- Defined contact force ensures that contact remains stable over the long term
- Clamping space opened by means of fixed screwdriver enables convenient conductor connection
- Unrestricted 600-V-UL approval thanks to compact zig-zag pinning
- Operation and conductor connection from one direction enable integration into front of device

Commercial data

Item number	1735846
Packing unit	50 pc
Minimum order quantity	1 pc
Sales key	055
Product key	AAOBCA
Catalog page	Page 467 (C-1-2013)
GTIN	4046356179485
Weight per piece (including packing)	60,64 g
Weight per piece (excluding packing)	60 g
Customs tariff number	85369010
Country of origin	BG

SPT 16/ 8-H-10,0-ZB - PCB terminal block



1735846

<https://www.phoenixcontact.com/za/products/1735846>

Technical data

Product properties

Type	PC terminal block can be aligned
Product line	COMBICON Terminals XL
Product type	Printed circuit board terminal
Product family	SPT 16/...-H
Number of positions	8
Pitch	10 mm
Number of connections	8
Number of rows	1
Number of potentials	8
Pin layout	Zigzag pinning W
Solder pins per potential	3

Electrical properties

Nominal current I_N	76 A
Nominal voltage U_N	1000 V
Degree of pollution	3
Rated voltage (III/3)	1000 V
Rated surge voltage (III/3)	8 kV
Rated voltage (III/2)	1000 V
Rated surge voltage (III/2)	8 kV
Rated voltage (II/2)	1000 V
Rated surge voltage (II/2)	6 kV

Connection data

Connection technology

Type	PC terminal block can be aligned
Nominal cross section	16 mm ²

Conductor connection

Connection method	Push-in spring connection
Conductor cross section rigid	0.75 mm ² ... 16 mm ²
Conductor cross section flexible	0.75 mm ² ... 16 mm ²
Conductor cross section AWG	20 ... 4
Conductor cross section flexible, with ferrule without plastic sleeve	0.75 mm ² ... 16 mm ²
Conductor cross section, flexible, with ferrule, with plastic sleeve	0.75 mm ² ... 10 mm ²
2 conductors with the same cross section, flexible, with TWIN ferrule with plastic sleeve	0.75 mm ² ... 4 mm ²
Stripping length	18 mm

Mounting

SPT 16/ 8-H-10,0-ZB - PCB terminal block



1735846

<https://www.phoenixcontact.com/za/products/1735846>

Mounting type	Wave soldering
Pin layout	Zigzag pinning W
Connection method	Push-in spring connection

Material specifications

Material data - contact

Note	WEEE/RoHS-compliant, free of whiskers according to IEC 60068-2-82/JEDEC JESD 201
Contact material	Cu alloy
Surface characteristics	Tin-plated
Metal surface terminal point (top layer)	Tin (10 - 16 μm Sn)
Metal surface soldering area (top layer)	Tin (10 - 16 μm Sn)

Material data - housing

Color (Housing)	green (6021)
Insulating material	PA
Insulating material group	I
CTI according to IEC 60112	600
Flammability rating according to UL 94	V0
Glow wire flammability index GWFI according to EN 60695-2-12	850
Glow wire ignition temperature GWIT according to EN 60695-2-13	775
Temperature for the ball pressure test according to EN 60695-10-2	125 °C

Dimensions

Dimensional drawing	
Pitch	10 mm
Width [w]	81.8 mm
Height [h]	34 mm
Length [l]	29 mm
Installed height	30 mm
Solder pin length [P]	4 mm
Pin dimensions	1.2 x 1 mm

PCB design

Pin spacing	15 mm
Hole diameter	1.7 mm

Mechanical tests

SPT 16/ 8-H-10,0-ZB - PCB terminal block



1735846

<https://www.phoenixcontact.com/za/products/1735846>

Connection test

Specification	IEC 60998-2-2:2002-12
Result	Test passed

Test for conductor damage and slackening

Specification	IEC 60998-2-2:2002-12
Result	Test passed

Pull-out test

Specification	IEC 60998-2-2:2002-12
Conductor cross section/conductor type/tractive force setpoint/actual value	0.75 mm ² / solid / > 30 N
	0.75 mm ² / flexible / > 30 N
	16 mm ² / solid / > 100 N
	16 mm ² / flexible / > 100 N

Flexion test

Specification	IEC 60998-2-2:2002-12
Result	Test passed

Insulation holder for crimp connections

Result	Test passed
--------	-------------

Electrical tests

Temperature-rise test

Specification	IEC 60998-2-1:2002-12
Requirement temperature-rise test	Increase in temperature ≤ 45 K

Insulation resistance

Specification	IEC 60998-1:2002-12
Insulation resistance, neighboring positions	> 5 MΩ

Air clearances and creepage distances |

Specification	IEC 60664-1:1992-10 + A1:2000-02 + A2:2002-05
Insulating material group	I
Comparative tracking index (IEC 60112)	CTI 600
Rated insulation voltage (III/3)	1000 V
Rated surge voltage (III/3)	8 kV
minimum clearance value - non-homogenous field (III/3)	8 mm
minimum creepage distance (III/3)	12.5 mm
Rated insulation voltage (III/2)	1000 V
Rated surge voltage (III/2)	8 kV
minimum clearance value - non-homogenous field (III/2)	8 mm
minimum creepage distance (III/2)	8 mm
Rated insulation voltage (II/2)	1000 V
Rated surge voltage (II/2)	6 kV
minimum clearance value - non-homogenous field (II/2)	5.5 mm

SPT 16/ 8-H-10,0-ZB - PCB terminal block



1735846

<https://www.phoenixcontact.com/za/products/1735846>

minimum creepage distance (II/2)	5.5 mm
----------------------------------	--------

Environmental and real-life conditions

Vibration test

Specification	IEC 60068-2-6:1995-03
Frequency	10 - 150 - 10 Hz
Sweep speed	1 octave/min
Amplitude	0.35 mm (10 Hz ... 60.1 Hz)
Sweep speed	5g (60.1 Hz ... 150 Hz)
Test duration per axis	2.5 h

Glow-wire test

Specification	IEC 60998-1:2002-12
Temperature	850 °C
Time of exposure	5 s

Ambient conditions

Ambient temperature (operation)	-40 °C ... 100 °C (Depending on the current carrying capacity/derating curve)
Ambient temperature (storage/transport)	-40 °C ... 70 °C
Relative humidity (storage/transport)	30 % ... 70 %
Ambient temperature (assembly)	-5 °C ... 100 °C

Packaging specifications

Type of packaging	packed in cardboard
-------------------	---------------------

SPT 16/ 8-H-10,0-ZB - PCB terminal block



1735846

<https://www.phoenixcontact.com/za/products/1735846>

Drawings

Diagram

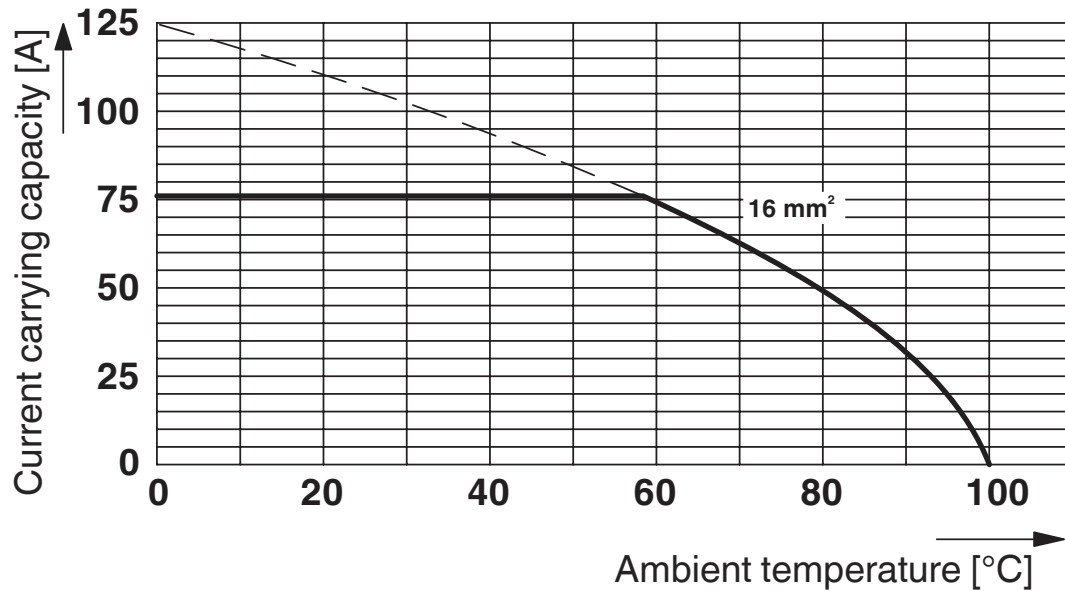

Type: SPT 16/...-H-10,0-ZB

Test based on DIN EN 60512-5-2:2003-01

Reduction factor = 1

Number of positions: 5

Dimensional drawing

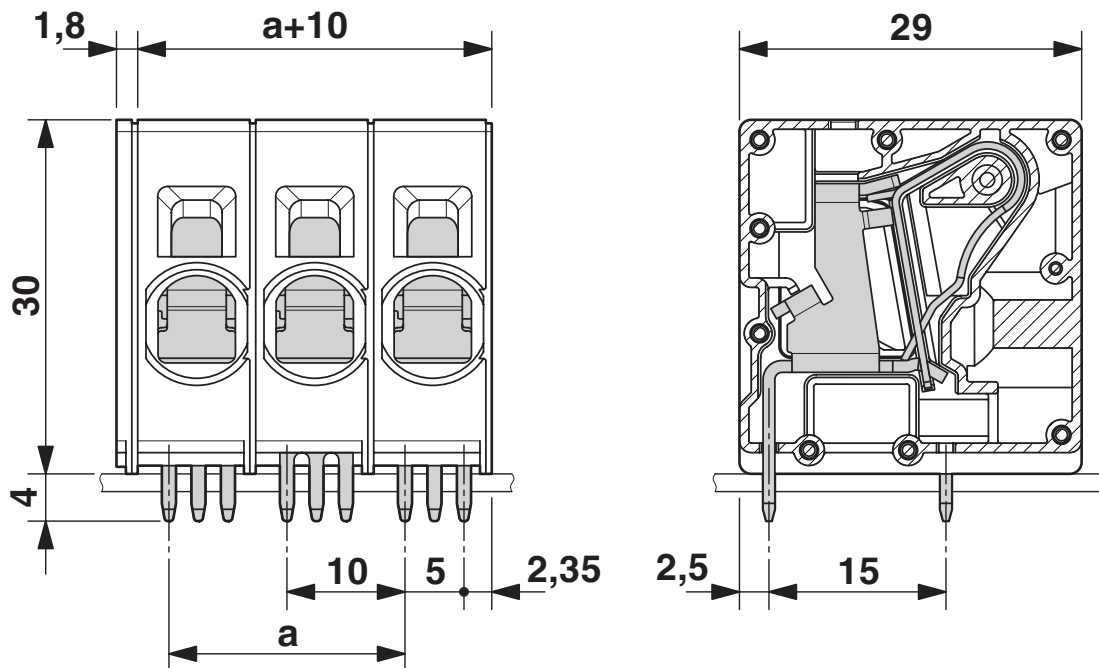

SPT 16/ 8-H-10,0-ZB - PCB terminal block

1735846

<https://www.phoenixcontact.com/za/products/1735846>



Drilling plan/solder pad geometry

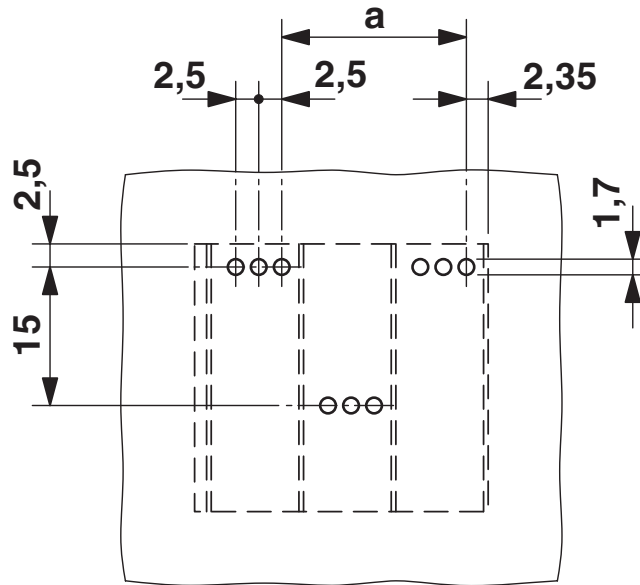

SPT 16/ 8-H-10,0-ZB - PCB terminal block





1735846

<https://www.phoenixcontact.com/za/products/1735846>

Approvals

To download certificates, visit the product detail page: <https://www.phoenixcontact.com/za/products/1735846>

 cULus Recognized Approval ID: E60425-20061129				
	Nominal voltage U_N	Nominal current I_N	Cross section AWG	Cross section mm^2
Use group B	600 V	66 A	20 - 4	-
Use group C	600 V	66 A	20 - 4	-

 VDE Zeichengenehmigung Approval ID: 40042909				
	Nominal voltage U_N	Nominal current I_N	Cross section AWG	Cross section mm^2
	1000 V	76 A	-	0.75 - 16

SPT 16/ 8-H-10,0-ZB - PCB terminal block



1735846

<https://www.phoenixcontact.com/za/products/1735846>

Classifications

ECLASS

ECLASS-11.0	27460101
ECLASS-12.0	27460101
ECLASS-13.0	27460101

ETIM

ETIM 9.0	EC002643
----------	----------

UNSPSC

UNSPSC 21.0	39121400
-------------	----------

SPT 16/ 8-H-10,0-ZB - PCB terminal block



1735846

<https://www.phoenixcontact.com/za/products/1735846>

Environmental product compliance

China RoHS	Environmentally friendly use period: unlimited = EFUP-e
	No hazardous substances above threshold values

Phoenix Contact 2024 © - all rights reserved
<https://www.phoenixcontact.com>

PHOENIX CONTACT (Pty) Ltd.
36 Lyn Road P.O. Box 916 ZA-Ferndale 2160

+27/11/801-8200
info@phoenixcontact.co.za