



Take Control

Experience Complete Satisfaction With Allen-Bradley Products

Since 1903, Rockwell Automation's Allen-Bradley has earned a worldwide reputation as the most trusted brand name in industrial automation. It's a reputation built on a very simple strategy: providing customers with products of uncompromising quality and reliability. The MicroLogix 1200 family of controllers demonstrates that commitment to high standards of product dependability, technological innovation, and performance.

More importantly, because your absolute satisfaction is important to us, we back our products with the highest levels of customer service and support in the industry. Your local Rockwell Automation representative is your source for expert sales and order support, as well as:

- Product technical training
- Warranty support
- Service agreements

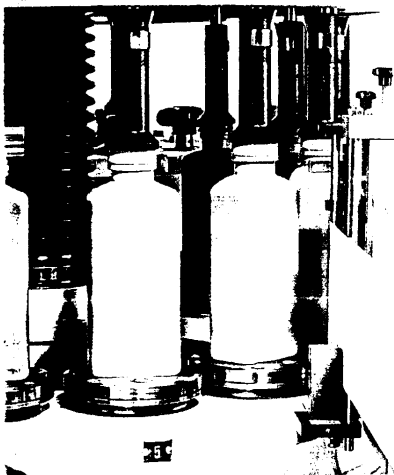

MicroLogix 1200 Processors:

High Functionality in a Compact, Cost-Effective Package

Some micro-PLCs force you to trade off between product size and functionality. Many applications requiring dedicated control also have rigorous space requirements. You may, however, want the freedom to expand your I/O as your application grows. Whatever the solution, though, it must be cost-effective.

With the MicroLogix 1200 family of micro-controllers, you can finally have the ideal blend of functionality and compact size, at a price that is more reasonable than you might expect.

The Footprint is Small, but the Functionality is Big

In 1994, we introduced the MicroLogix 1000, a miniature controller offering task-specific dedicated control at a very low price. Later came the MicroLogix 1500 with expansion I/O to suit complex, ever-growing applications.

Now there is the MicroLogix 1200, bringing together the best of both products.

The MicroLogix 1200 controllers are truly micro in size. With a footprint as small as 3.54" x 4.33" (90mm x 110mm), they are ideal

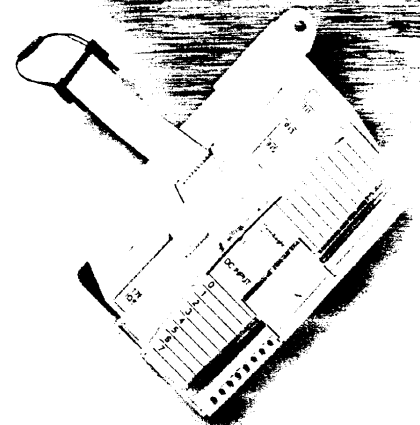
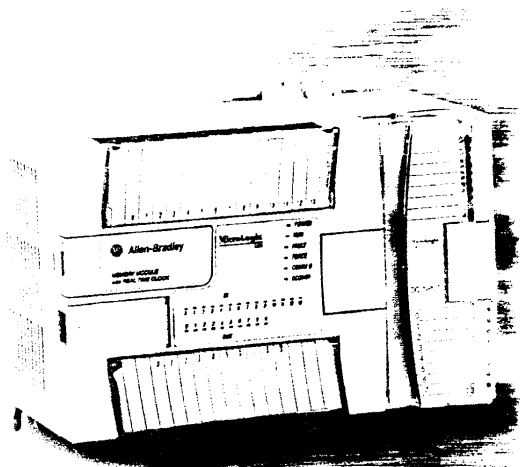

for control projects where panel space is a challenge. Make no mistake, though — small size does not mean small functionality. These tiny packages are filled with an abundance of features designed to accommodate a broad range of applications.

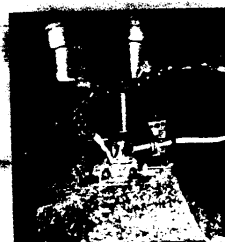

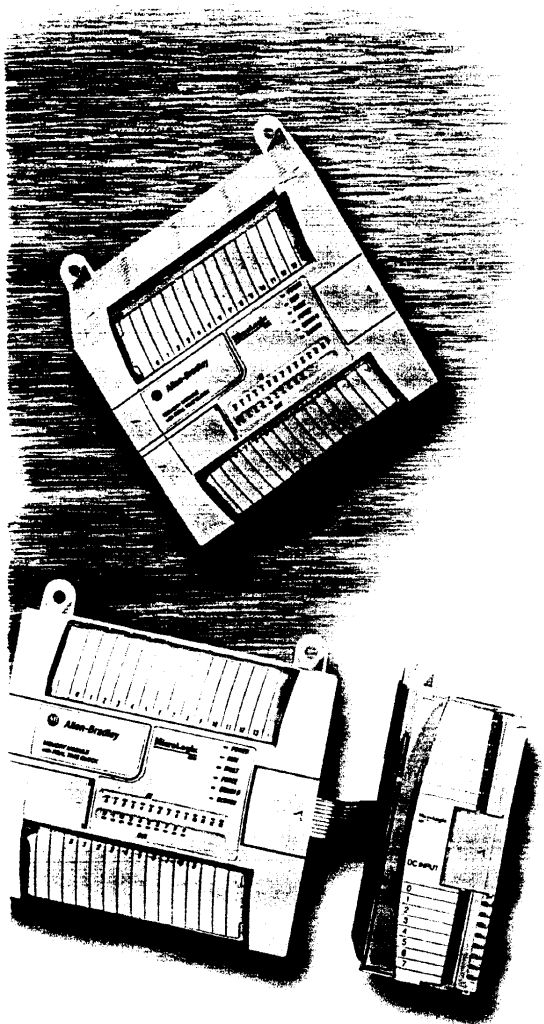

Expansion I/O

The MicroLogix 1200 makes use of discrete and analog expansion I/O modules (providing up to 88 points) for a lot of application flexibility. Removable I/O labels with a write-on area make for easy field device identification to reduce valuable troubleshooting and maintenance

time. Finally, finger-safe terminal blocks make for safe operation by meeting global safety standards.

Compatible Instructions Sets and Programming Software

Because it is part of the MicroLogix/SLC family, the MicroLogix 1200 features an instruction set that is compatible with other MicroLogix controllers as well as SLC 500 controllers. That means that programs written for the MicroLogix 1000, MicroLogix 1500 or SLC 500 can be easily scaled for the MicroLogix 1200.

Likewise, the MicroLogix 1200 is compatible with Rockwell

Software RSLogix 500 programming software, a feature-rich Windows® based package used to program a host of Allen-Bradley controllers. The result of this compatibility — reduced time spent training personnel and developing applications due to software familiarity and program reusability.

Large Non-Volatile Memory

Similar to the MicroLogix 1500, the MicroLogix 1200 boasts a large 6K memory, with 4K words available for user programs and configurable 2K words for user data. This feature of the MicroLogix 1200 expands application coverage by allowing data elements to be selected according to individual application requirements.

MicroLogix 1200 Features

Other features of the MicroLogix 1200 include:

- Real time clock & memory modules
- Communication features:
 - Built-in RS-232C port supporting DF1 full and half-duplex protocols and DH485 protocol
 - New embedded Modbus RTU slave protocol
- Direct connectivity to either DeviceNet or DH485 network interfaces
- 20 kHz High Speed Counter with eight modes of operation and direct control of outputs (independent of program scan)
- Built-in analog trim potentiometers



Table of Contents

Refer to the MicroLogix Selector Guide on the back cover of this publication for assistance in selecting the correct MicroLogix Programmable Controller for your application.

Inside...	Page
MicroLogix 1200 System	5
Expansion I/O Modules	8
Communication Choices	12
Network Interface Devices	15
Programming Software	18
Programming Instructions	20
Operator Interface Devices	21
Accessories	22
User Documentation	23
Dimensions	24

MicroLogix 1200 System

The MicroLogix 1200 programmable controllers are integrated packages of processor, power supply and embedded inputs and outputs. The 24-point and 40-point controllers provide the computing power to solve a variety of applications utilizing the proven MicroLogix family and SLC family architecture.

The MicroLogix 1200's modular, rackless design provides for lower system cost and reduced parts inventory. Expansion I/O modules allow for greater application flexibility.

Memory modules allow user programs to be uploaded, downloaded and easily transported. Real-Time Clock (RTC) capabilities allow time scheduling of control.

A flash upgradeable operating system makes it easy to upgrade operating systems without having to replace hardware. Your controller can be updated with latest firmware via a Web site download of ControlFlash software.

The MicroLogix 1200 controllers also utilize Rockwell Software RSLogix 500™ programming software and feature a common instruction set to the MicroLogix 1000, MicroLogix 1500 and SLC families of controllers.

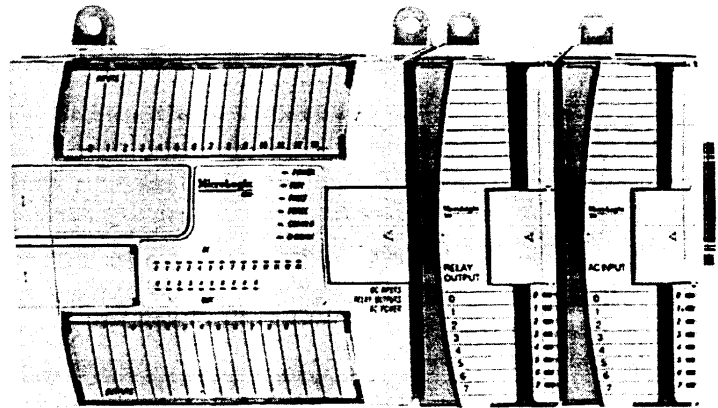

Features:

- High-performance I/O expansion through MicroLogix 1200 Expansion I/O. Up to six expansion I/O modules per MicroLogix 1200 controller (depending on power budget)
- Advanced communications options, from peer-to-peer to SCADA/RTU networks.
- 6K user memory (4K program, 2K data)
- Data file download protection, saving critical user data from being overwritten during logic transfers
- Real-time clock and memory modules
- 32-bit signed integer math
- Built-in PID capabilities
- 20 kHz high-speed counter, featuring eight modes of operation. Outputs can be controlled when counter reaches programmed high or low preset levels.
- Four interrupt inputs for high-speed processing
- Four latching inputs to capture microsecond pulses to be processed during normal program scan.
- Two analog trim potentiometers built into the controller. A 3/4 turn adjusts an integer between 0 and 250.
- Removable terminal blocks on 40-point controllers, allows for pre-wiring of the controller and saves installation time.
- Removable label with write-on area for easy field device identification, saving valuable maintenance time.
- Finger-safe terminal blocks, meeting global safety standards.
- Regulatory agency certifications pending

Controller Specifications

General Specifications

Description	1762-L24AWA	1762-L24BWA	1762-L40AWA	1762-L40BWA
Dimensions	Height: 90 mm 104 mm (with DIN latch open) Width: 110 mm Depth: 87 mm		Height: 90 mm 104 mm (with DIN latch open) Width: 160 mm Depth: 87 mm	
Number of I/O	14 inputs 10 outputs	14 inputs 10 outputs	24 inputs 16 outputs	24 inputs 16 outputs
Line Power	85/265V ac	85/265V ac	85/265V ac	85/265V ac
Power Supply	120V ac 240 V ac			
Power Supply Maximum Inrush	120V ac = 25 A for 8 ms 240V ac = 40 A for 4 ms			
User Power Output	none	24V dc at 250 mA	none	24V dc at 400 mA
Input Circuit Type	120V ac	24V dc sink/source	120V ac	24V dc sink/source
Output Circuit Type	Relay	Relay	Relay	Relay
Operating Temperature	+0°C to +55°C (+32°F to +131°F) ambient			
Storage Temperature	-40°C to +85°C (-40°F to +185°F) ambient			
Operating Humidity	5% to 95% relative humidity (non-condensing)			
Agency Certification	Regulatory agency certifications pending			

For complete specifications on the MicroLogix 1200 controllers, refer to Appendix A of the *MicroLogix 1200 Programmable Controllers User Manual*, publication 1762-UM001A-US-P (available February 2000). To purchase this manual or download a free electronic version, visit us at <http://www.theautomationbookstore.com>. Or, for fast access to related publications, visit the MicroLogix Internet site <http://www.ab.com/micrologix>. Electronic versions of our manuals are available for you to search and download.

Input Specifications

Description	1762-L24AWA 1762-L40AWA	1762-L24BWA and 1762-L40BWA	
		Inputs 0 through 3	Inputs 4 and higher
On-State Voltage Range	79 to 132V ac	14 to 26.4V dc at 55°C (131°F) 14 to 30.0V dc at 30°C (86°F)	10 to 26.4V dc at 55°C (131°F) 10 to 30.0V dc at 30°C (86°F)
Off-State Voltage Range	0 to 20V ac	0 to 5V dc	
Operating Frequency	47 Hz to 63 Hz	0 Hz to 20 kHz	0 Hz to 1 kHz (scan time dependent)
On-State Current:	5.0 mA at 79V dc (min.) 12 mA at 120V dc (nom.) 6.0 mA at 132V dc (max.)	2.5 mA at 14V dc (min.) 8.8 mA at 24V dc (nom.) 12.0 mA at 30V dc (max.)	2.0 mA at 10V dc (min.) 8.5 mA at 24V dc (nom.) 12.0 mA at 30V dc (max.)
Off-State Leakage Current	2.5 mA max.	1.5 mA min.	
Nominal Impedance	12K Ω at 50 Hz 10K Ω at 60 Hz	2.5K Ω	2.6K Ω
Inrush Current (max.) at 120V ac	250 mA	Not Applicable	

7

Relay Contact Rating Table 1764-L24AWA, -L24BWA, -L40AWA, -L40BWA

Maximum Volts	Amperes		Amperes Continuous	Volt-amperes	
	Make	Break		Make	Break
240V ac	7.5A	0.75A	2.5A	1800 VA	180 VA
120V ac	15A	1.5A	2.5A	1800 VA	180 VA
125V dc	0.22A ⁽¹⁾			1.0A	
24V dc	1.2A			2.0A	

(1) For dc voltage applications, the make/break ampere rating for relay contacts can be determined by dividing 28 VA by the applied dc voltage. For example, 28 VA/48V dc = 0.58A. For dc voltage applications less than 48V, the make/break ratings for relay contacts cannot exceed 2A.

Output Specifications - Maximum Continuous Current

Specification	1762-L24AWA, 1762-L24BWA	1762-L40AWA, 1762-L40BWA
Current per Common	8A	8A
Current per Controller	at 150V ac max	25A ⁽¹⁾
	at 240V ac max	20A ⁽¹⁾
		30A ⁽²⁾
		20A

(1) 15A above 40°C (104°F)

(2) 24A above 40°C (104°F)

Expansion I/O Modules

MicroLogix 1200 I/O expansion modules provide superior functionality at a low cost. With a variety of modules, they complement and extend the capabilities of the MicroLogix 1200 controllers by maximizing flexibility of the I/O count and type.

MicroLogix 1200 I/O has a modular, rackless design. Elimination of the I/O rack from the system enhances cost savings and reduces replacement parts inventory.

The MicroLogix I/O package design allows modules to be either DIN rail or panel mounted. The DIN latches and screw mounting holes are an integral part of the package design.

Features:

- Rackless design, eliminating added system costs and inventory
- Small footprint, shrinking panel space requirements
- Integral high-performance I/O bus
- Software keying to prevent incorrect positioning within the system
- Feature-rich I/O functionality addresses a wide range of applications
- AC/DC relay, 24V dc, and 120V ac voltages

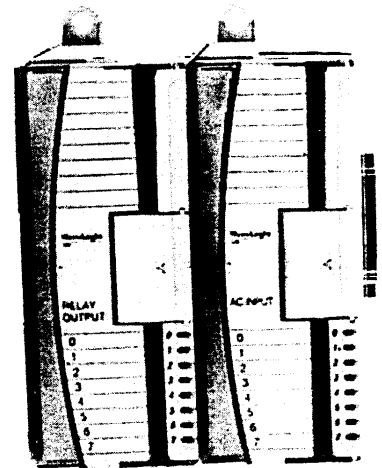

Available modules include:

1762-IA8	8 point 120V ac Input Module
1762-IQ8	8 point 24V dc Sinking/Sourcing Input Module
1762-OW8	8 point ac/dc Relay Output Module
1762-IF20F2	2 channel Inputs/2 channel Outputs Analog Module

For complete information on the MicroLogix 1200 I/O modules, refer to the *MicroLogix 1200 Programmable Controllers User Manual*, publication 1762-UM001A-US-P. To purchase this manual or download a free electronic version, visit us at <http://www.theautomationbookstore.com>. Or, for fast access to related publications, visit the MicroLogix Internet site <http://www.ab.com/micrologix>. Electronic versions of our manuals are available for you to search and download.

Expansion I/O Modules Common Specifications

Specification	Value
Dimensions	90 mm (height) x 87 mm (depth) x 40 mm (width) height including mounting tabs is 110 mm 3.543 in. (height) x 3.425 in. (depth) x 1.575 in. (width) height including mounting tabs is 4.33 in.
Operating Temperature	0°C to +55°C (-32°F to +131°F)
Operating Humidity	5% to 95% non-condensing
Operating Altitude	2000 meters (6561 feet)
Noise Immunity	NEMA standard ICS 2-230
Radiated and Conducted Emissions	EN50081-2 Class A
<i>Electrical /EMC:</i>	<i>The module has passed testing at the following levels:</i>
ESD Immunity (IEC1000-4-2)	4 kV contact, 8 kV air, 4 kV indirect
Radiated Immunity (IEC1000-4-3)	10 V/m, 80 to 1000 MHz, 80% amplitude modulation, +900 MHz keyed carrier
Fast Transient Burst (IEC1000-4-4)	2 kV, 5 kHz
Surge Immunity (IEC1000-4-5)	2 kV common mode, 1 kV differential mode
Conducted Immunity (IEC1000-4-6)	10V, 0.15 to 80 MHz ⁽¹⁾

(1) Conducted Immunity frequency range may be 150 kHz to 30 MHz if the Radiated Immunity frequency range is 30 MHz to 1000 MHz.

Input Specifications

Specification	1762-IA8	1762-IQ8
Voltage Category	100/120V ac	24V dc (sink/source) ⁽¹⁾
Operating Voltage Range	79V ac to 132V ac at 47 Hz to 63 Hz	10 to 26.4V dc at 55°C (131°F) 10 to 30V dc at 30°C (86°F)
Number of Inputs	8	8
Bus Current Draw (max.)	50 mA at 5V dc (0.25W)	50 mA at 5V dc (0.25W)
Heat Dissipation (max.)	2.0 Total Watts	3.7 Total Watts
Signal Delay (max.)	On Delay: 20.0 ms Off Delay: 20.0 ms	On Delay: 8.0 ms Off Delay: 8.0 ms
Off-State Voltage (max.)	20V ac	5V dc
Off-State Leakage Current (max.)	2.5 mA	1.5 mA
On-State Voltage (min.)	79V ac (min.) 132V ac (max.)	10V dc
On-State Current	5.0 mA (min.) at 79V ac 47 Hz 12.0 mA (nominal) at 120V ac 60 Hz 16.0 mA (max.) at 132V ac 63 Hz	2.0 mA min. at 10V dc 8.0 mA nominal at 24V dc 12.0 mA max. at 30V dc
Inrush Current (max.)	250 mA	Not Applicable
Nominal Impedance	12K Ω at 50 Hz 10K Ω at 60 Hz	3K Ω
Power Supply Distance Rating	6	6

(1) Sinking/Sourcing Inputs - Sourcing/sinking describes the current flow between the I/O module and the field device. Sourcing I/O circuits supply (source) current to sinking field devices. Sinking I/O circuits are driven by a current sourcing field device. Field devices connected to the negative side (DC Common) of the field power supply are sinking field devices. Field devices connected to the positive side (+V) of the field supply are sourcing field devices.

Output Specifications

Specification	1762-0W8
Voltage Category	AC/DC normally open relay
Operating Voltage Range	5 to 265V ac 5 to 125V dc
Number of Outputs	8
Bus Current Draw (max.)	80 mA at 5V dc (0.40W) 90 mA at 24V dc (2.16W)
Heat Dissipation (max.)	2.9 Total Watts
Signal Delay (max.) - resistive load	On Delay: 10 ms Off Delay: 10 ms
Off-State Leakage (max.)	0 mA
On-State Current (min.)	10 mA at 5V dc
Continuous Current per Point (max.)	2.5A ⁽¹⁾
Continuous Current per Common (max.)	8A
Continuous Current per Module (max.)	16A
Power Supply Distance Rating	6

(1) See Relay Contact Rating Table on page page 7.

10

Analog I/O Module

The 1762-IF2OF2 analog combination input/output module converts and digitally stores analog data for use by the MicroLogix 1200 controllers. The module supports connections from any combination of up to two voltage or current analog sensors. The two output channels provide two single-ended analog output channels, each individually configurable for voltage or current. This provides application flexibility, reduces stock inventory and lessens the learning curve.

MicroLogix 1200 I/O's analog module provides 12-bit resolution, making it an excellent choice for applications that monitor and control small changes in the analog value.

The MicroLogix 1200 analog module provides the following input/output types/ranges:

- 0 to 10V dc
- 0 to 20 mA
- 4 to 20 mA

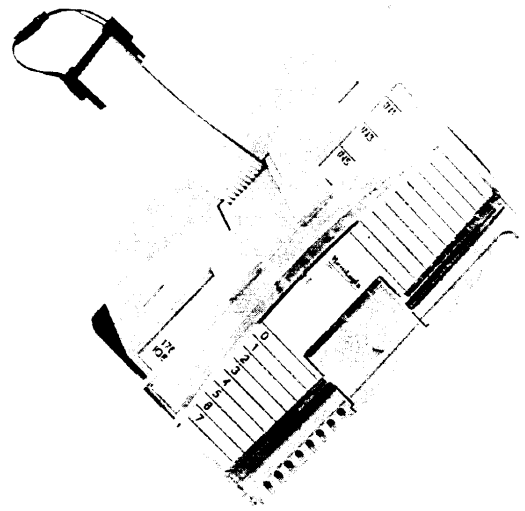

Analog Specifications

Specification	Value
Analog Normal Operating Range	Voltage: 0 to 10V Current: 4 to 20 mA
Resolution ⁽¹⁾	12 bits
Repeatability ⁽²⁾	±0.1% (max.)
Input and Output Group to Backplane Isolation	30V ac/30V dc rated working voltage ⁽³⁾ (IEC Class 2 reinforced insulation) ±0.1% type test: 500V ac or 707V dc for 1 minute

(1) Unipolar, over the full scale analog range.

(2) Repeatability is the ability of the input module to register the same reading in successive measurements for the same input signal.

(3) Rated working voltage is the maximum continuous voltage that can be applied at the input terminal, including the input signal and the value that floats above ground potential (for example, 10V dc input signal and 20V dc potential above ground).

11

Analog Input Specifications

Specification	Value
Number of Inputs	2 differential (unipolar)
Non-linearity (in percent full scale)	±0.1%
Input Impedance	Voltage Terminal: 200K Ω Current Terminal: 250 Ω
Channel Diagnostics	Over- or under-range or open-circuit condition by bit reporting for analog inputs.

Analog Output Specifications

Specification	Value
Number of Outputs	2 single-ended (unipolar)
Resistive Load on Current Output	0 to 500 Ω (includes wire resistance)
Load Range on Voltage Output	> 1K Ω
Non-linearity (in percent full scale)	±0.5% (max.)
Open and Short-Circuit Protection	Yes
Output Overvoltage Protection	Yes

Communication Choices

All MicroLogix 1200 programmable controllers provide several communication options to fit into a variety of applications.

The DF1 Full-Duplex protocol allows the MicroLogix 1200 to communicate directly with another device, such as a personal computer or an operator interface device. The DF1 Full-Duplex protocol (also referred to as DF1 point-to-point protocol) is useful where RS-232 point-to-point communication is required.

The DH485 multi-drop communication capability allows you to network up to 32 MicroLogix or SLC 500 controllers, Human/Machine Interface (HMI) devices and/or personal computers using peer-to-peer messaging.

And, the MicroLogix 1200 can communicate on a DeviceNet network as well. DeviceNet digitally links push buttons, sensors, actuators, PLCs and other industrial devices on an open network.

MicroLogix 1200 controllers also support DF1 Half-Duplex Slave communications for use in SCADA systems as a Remote Terminal Unit (RTU). This open network protocol enables MicroLogix controllers to communicate as responder (slave) nodes on DF1 master/slave networks. DF1 supports up to 254 responder devices with a single master.

Additionally, the MicroLogix 1200 supports Modbus Slave, a SCADA/RTU protocol.

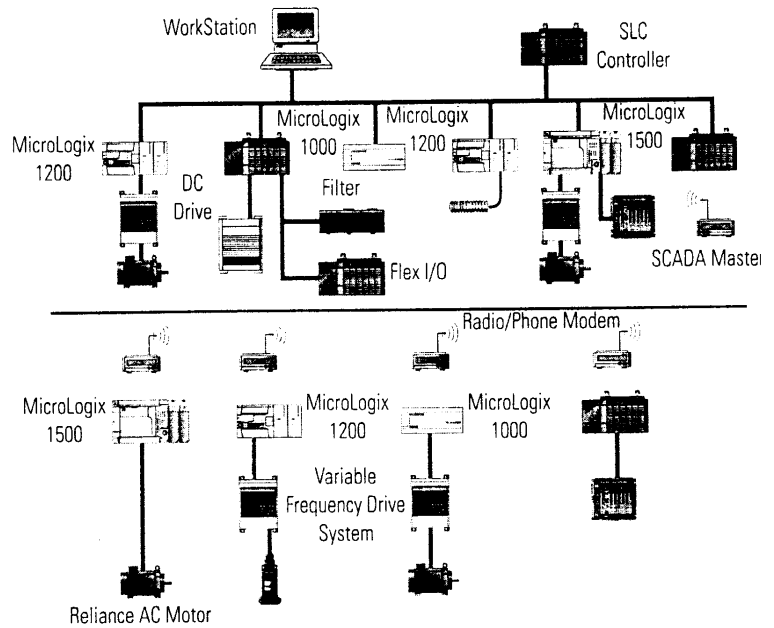

Features:

- Standard RS-232 port
- 300, 600, 1200, 4800, 9600, 19,200, and 38,400 baud rates
- RTS/CTS Hardware handshake signals
- Connection to DH485 and DeviceNet networks through 1761-NET-AIC and 1761-NET-DNI, respectively
- Connection to modems for remote communications
- ASCII messaging provides dial-out capability

The MicroLogix 1200 allows you to choose the network that best meets your needs.

If your application requires:	Use this network
<ul style="list-style-type: none"> • Connection of low-level multi-vendor devices directly to plant floor controllers • Data sharing between 64 devices • Better diagnostics for improved data collection and fault detection • Less wiring and reduced start-up time than traditional, hard-wired systems 	DeviceNet via the 1761-NET-DNI
<ul style="list-style-type: none"> • Plant-wide and cell-level data sharing with program maintenance • Data sharing between 32 controllers • Program upload, download, and monitoring to all controllers • Compatibility with multiple Allen-Bradley HMI devices 	DH485 via the 1761-NET-AIC
<ul style="list-style-type: none"> • Connection to dial-up modems for remote program maintenance or data collection • Connection to leased-line or radio modems for use in SCADA systems • Remote Terminal Unit (RTU) functions 	DF1 Full-Duplex DF1 Half-Duplex Slave
<ul style="list-style-type: none"> • Connection to modems for remote data collection in a SCADA system • Remote Terminal Unit (RTU) functions 	Modbus RTU Slave

Local Messages

The MicroLogix 1200 is capable of communicating using local or remote messages. With a local message, all devices are accessible without a separate device acting as a bridge. Different types of electrical interfaces may be required to connect to the network, but the network is still classified as a local network. Remote messages use a remote network, where devices are accessible only by passing or routing through a device.

The following four examples represent different types of local and remote networks.

Example 1 - Local DH485 Network with AIC+ (1761-NET-AIC) Interface

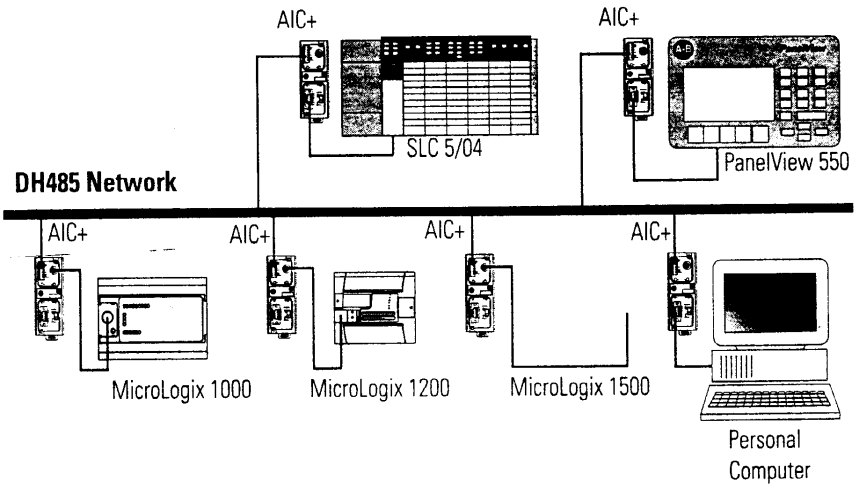

Example 2 - Local DeviceNet Network with DeviceNet Interface (1761-NET-DNI)

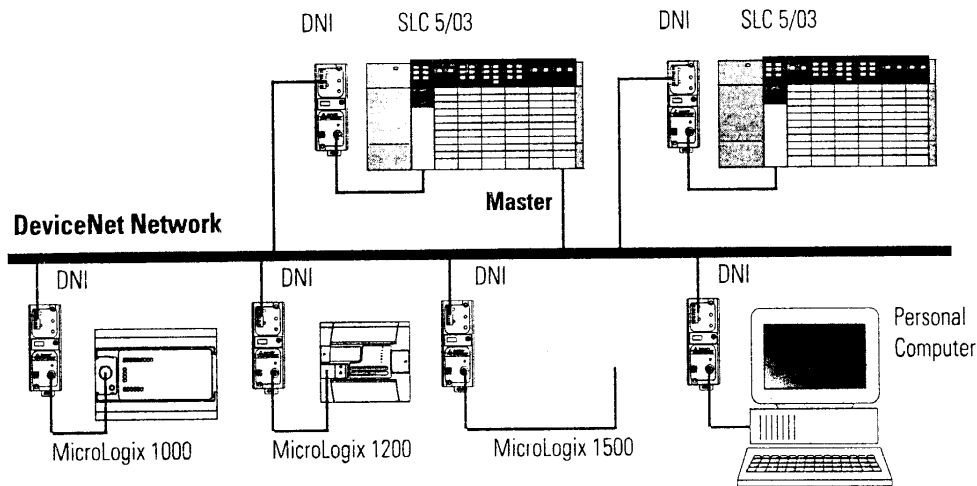

Example 3 - Local DF1 Half-Duplex Network

Rockwell Software WINtelligent LINX, RSLinx 2.0 (or higher), SLC 5/03, SLC 5/04, and SLC 5/05, or PLC-5 processors configured for DF1 Half-Duplex Master.

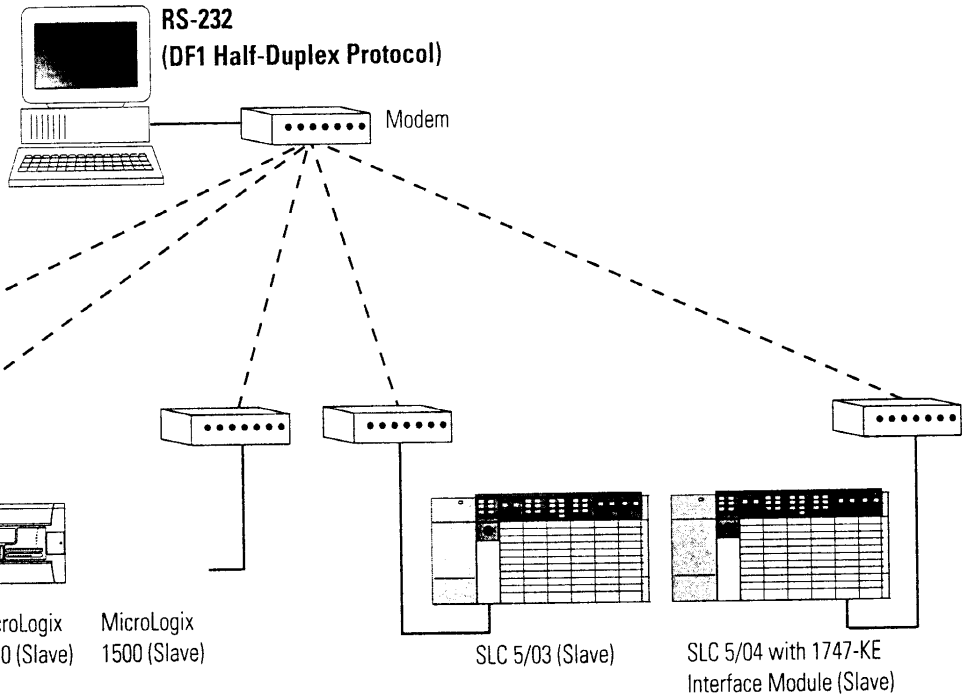

14

NOTE

It is recommended that isolation (1761-NET-AIC) be provided between the controller and the modem when using a non-isolated port.

Example 4 - Remote Messaging

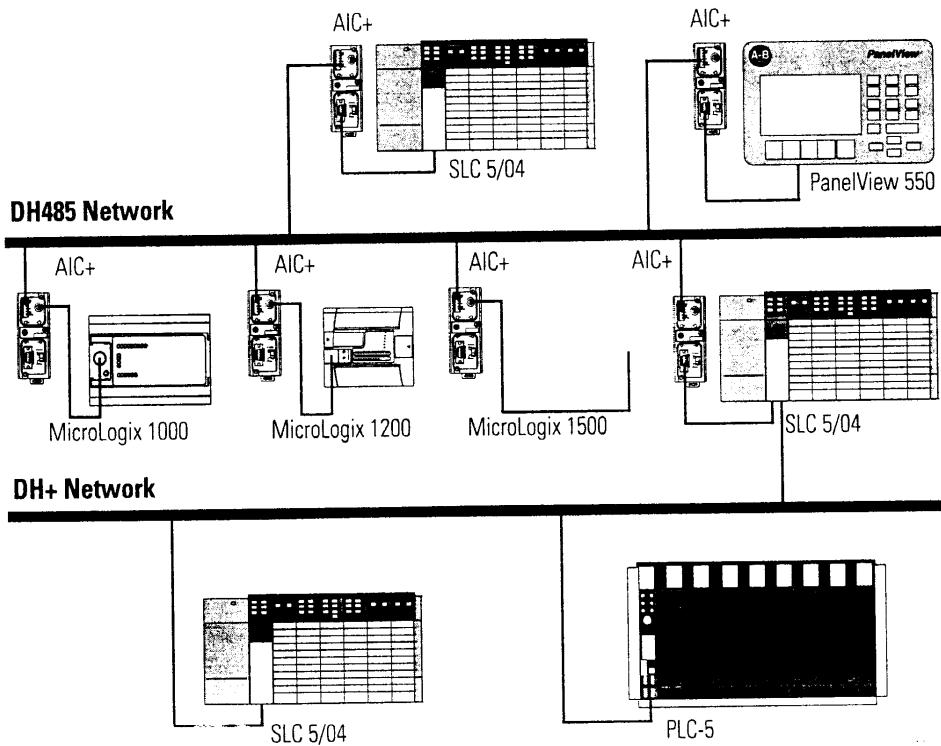

Network Interface Devices

The MicroLogix 1200 Programmable Controller's list of impressive hardware, memory, and processing features makes this family of controllers an ideal choice for applications with up to 88 I/O. And, with the DeviceNet Interface, you can connect MicroLogix Programmable Controllers and other DF1 compatible devices to a DeviceNet network. Additionally, with the 1761-NET-DNI DeviceNet Interface and 1761-NET-AIC Advanced Interface Converter (AIC+), you can connect MicroLogix Programmable Controllers to DH485 and DeviceNet networks.

For detailed information on using the network interface modules, refer to the *DeviceNet™ Interface User Manual*, publication 1761-6.5, and the *AIC+ Advanced Interface Converter User Manual*, publication 1761-6.4. To purchase these manuals or download a free electronic version, visit us at

<http://www.theautomationbookstore.com>.

For fast access to related publications, visit the MicroLogix Internet site

<http://www.ab.com/micrologix>. Electronic versions of our manuals are available for you to search and download.

1761-NET-DNI DeviceNet Interface Module

Highlights of the DeviceNet Interface's capabilities are:

- Peer-to-peer messaging between Allen-Bradley controllers and other devices using the DF1 Full-Duplex protocol
- Programming and on-line monitoring over the DeviceNet network
- With a DNI connected to a modem, you can dial in to any other DNI-controller combination on DeviceNet
- Other DeviceNet products can send explicit (Get or Set) messages with the DNI at any time
- The controller can initiate an explicit message to any UCMM (Unconnected Message Manager) compatible device on DeviceNet

15

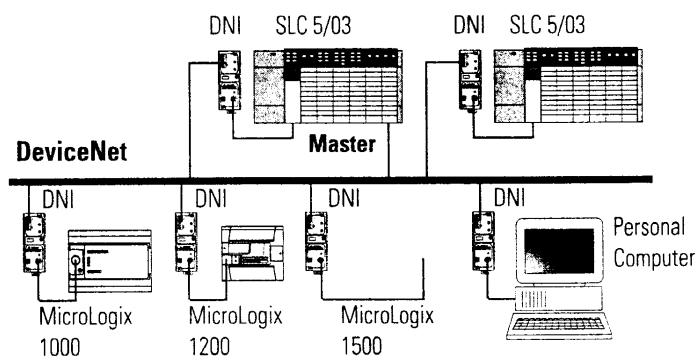

MicroLogix micro-PLCs extend the benefits of distributed control to the device level of your process with the addition of DeviceNet functionality.

DeviceNet digitally links push buttons, sensors, actuators, PLCs and other industrial devices. It reduces the installation and maintenance costs of multiple discrete wires with a single cable that handles both communications and power distribution.

The 1761-NET-DNI Series B Interface (DNI) brings the fast response, low cost and reliability of open DeviceNet connectivity to all MicroLogix controllers and most other Allen-Bradley controllers.

MicroLogix on DeviceNet lets you take advantage of the latest advances in communications. DeviceNet uses producer/consumer technology which significantly reduces the amount of traffic on the network, thus improving efficiency and data throughput. As a result, information gets across the network quicker.

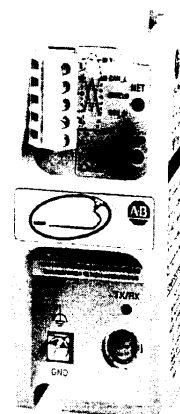

Advanced Slave I/O Functionality

Through the DNI, MicroLogix controllers can function as cost-effective DeviceNet slave nodes. The DNI presents to DeviceNet up to 64 words of data (32 inputs, 32 outputs, configurable). The DNI can either poll or accept data sent from the MicroLogix controller to keep its mapped I/O data up-to-date with the actual data in the controller, while the DNI handles all DeviceNet communications.

All local I/O remains under the MicroLogix controller's direct control, yet can be visible to the DeviceNet master.

16 Using standard messaging commands, you can easily read or write data to other controllers as shown in the network diagram on page 15.

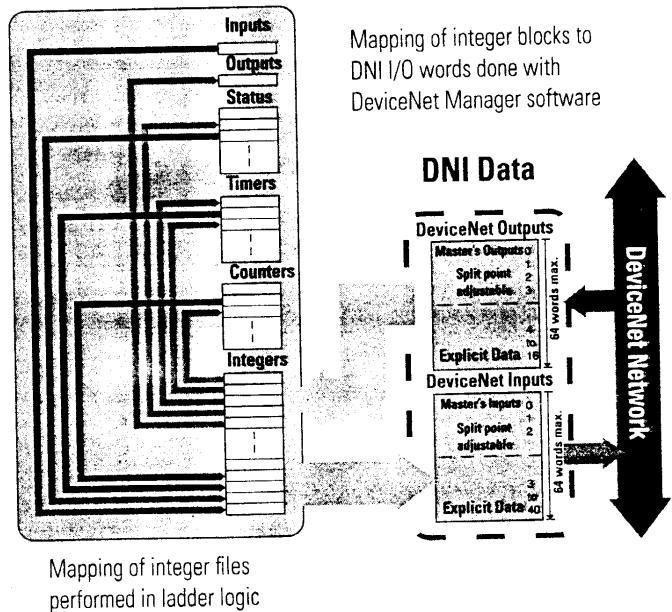

Mapping of integer blocks to DNI I/O words done with DeviceNet Manager software

Simple, Reliable Peer-to-Peer Messaging

The DNI brings brand-new functionality to DeviceNet by enabling peer-to-peer messaging between devices that use the DF1 Full-Duplex protocol.

The DNI takes the DF1 Full-Duplex commands, wraps them in the DeviceNet protocol and sends them to the target DNI. The target DNI removes the DeviceNet information and passes the DF1 command to the end device.

This capability works between controllers, PCs and controllers, and for program up/downloading. I/O and data messages are prioritized, which minimizes I/O determinism problems typically encountered on networks that support I/O and messaging simultaneously.

Enable Your Control Strategy Now

Helpful information and free DNI configuration software are also available at <http://www.ab.com/micrologix>. For more on the DeviceNet standard, visit <http://www.odva.org>.

DeviceNet Interface Series B (1761-NET-DNI) Specifications

Description	Specifications
24V dc Power Source Requirements	11 to 25V dc
Current Draw	200 to 250 mA 400 mA maximum inrush current (30 msec, max.)
Internal Isolation	500V dc
Operating Ambient Temperature	0 to +60°C (+32 to +140°F)
Storage Temperature	-40 to +85°C (-40 to +175°F)
Agency Certification	UL 1604 C-UL C22.2 No. 213 Class 1, Division 2, Groups A, B, C, D CE compliant for all applicable directives ODVA conformance 2.0-A12
DeviceNet	maximum number of nodes = 64 maximum length = 500m at 125K baud or 100m at 500K baud

AIC+ Advanced Interface Converter

The AIC+ is a networking device from Allen-Bradley that provides DH485 network access from any DH485 compatible device that has a RS-232 port, including all MicroLogix controllers, SLC 5/03 and 5/04, and PanelView 550 and 900. In addition, the device provides isolation between all ports for a more stable network and protection for connected devices. The unit is DIN rail or panel mountable and is industrially hardened.

The Advanced Interface Converter provides a simple, cost-effective solution for connecting RS-232 devices to a DH485 network. The AIC+ also provides:

- Two isolated RS-232 connections - one 9-pin D-shell and one 8-pin mini DIN
- An RS-485 6-pin Phoenix connection
- Power acceptance via the 8-pin mini DIN from a MicroLogix controller or an external power connection
- Compatibility with existing SLC DH485 networks that use 1747-AICs
- Auto baud rate capability for ease of system set-up
- Diagnostic LEDs for network activity

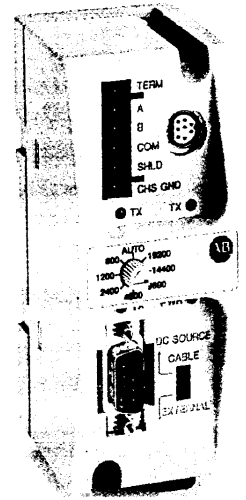

Some typical applications include:

- Connecting a personal computer to a DH485 network
- Connecting MicroLogix controllers to a DH485 network
- Linking SLC 5/03 or SLC 5/04 processors using DF1 Half-Duplex master/slave protocol. This allows you to connect remote islands of automation to a master controller to upload diagnostic and status information.

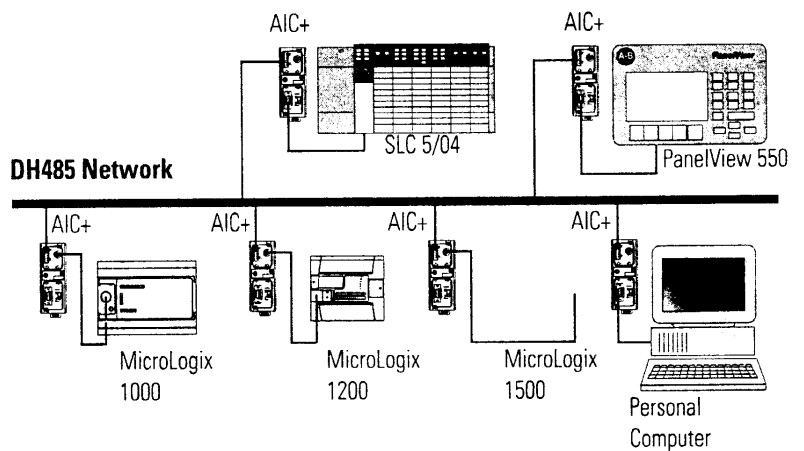

Advanced Interface Converter (1761-NET-AIC) Specifications

Description	Specifications
24V dc Power Source Requirement	20.4 - 28.8V dc
Current Draw	120 mA 200 mA maximum inrush current
Internal Isolation	500V dc
Operating Ambient Temperature	0 to +60°C (+32 to +140°F)
Storage Temperature	-40 to +85°C (-40 to +175°F)
Agency Certification	UL 1604 C-UL C22.2 No. 213 Class 1, Division 2, Groups A, B, C, D CE compliant for all applicable directives
DH485, DF1, or user Network	maximum number of nodes = 32 per multidrop network maximum length = 1,219m (4,000 ft.) per multidrop network maximum number of "ganged" multidrop networks = 2

Programming Software

The following sections describe programming options available for the MicroLogix 1200 controllers. With RSLogix 500™ Programming Software, you can create, modify, and monitor application programs used by the MicroLogix 1000, MicroLogix 1500, and SLC 500 Programmable Controller families.

18

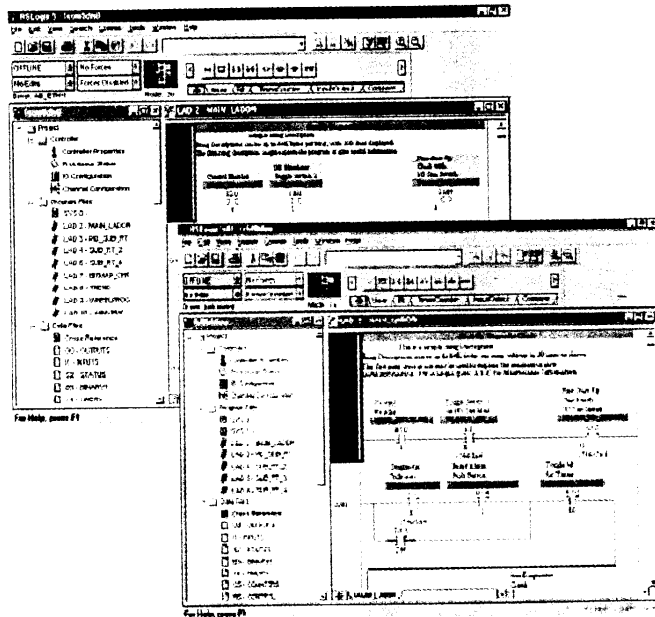

RSLogix 500 Programming Software

The RSLogix 500 ladder logic programming package helps you maximize performance, save project development time, and improve productivity. This product has been developed to operate on Microsoft's 32-bit, Windows® 95, Windows® 98, and Windows NT™ operating systems. Supporting SLC 500 and MicroLogix families of processors, RSLogix 500 was the first PLC programming software to offer unbeatable productivity with an industry-leading user interface.



Flexible, Easy-to-Use Editors

Flexible program editors let you create application programs without worrying about getting the syntax correct as you create your program. A *Project Verifier* builds a list of errors that you can navigate to make corrections at your convenience.

Drag-and-drop editing lets you quickly move or copy instructions from rung to rung within a project, rungs from one subroutine or project to another, or data table elements from one data file to another.

Context menus for common software tools are quickly accessible by clicking the right mouse button on addresses, symbols, instructions, rungs, or other application objects. This convenience provides you with all the necessary functionality to accomplish a task within a single menu.

Point-and-Click I/O Configuration

The easy-to-use I/O Configurator lets you click or drag-and-drop a module from an all-inclusive list to assign it a slot in your configuration. Advanced configuration, required for specialty and analog modules, is easily accessible. Convenient forms speed entry of configuration data. An I/O auto configuration feature is also available.

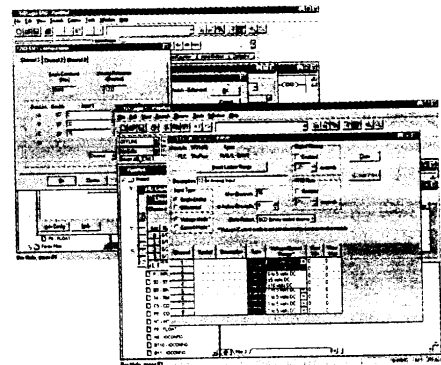

Point-and-Click I/O Configuration

Powerful Database Editor

Use the *Symbol Group Editor* to build and classify groups of symbols so that you can easily select portions of your recorded documentation to be used from project to project.

Use the *Symbol Picker* list to easily address instructions in your ladder logic by clicking addresses or symbols to assign them to your ladder instructions.

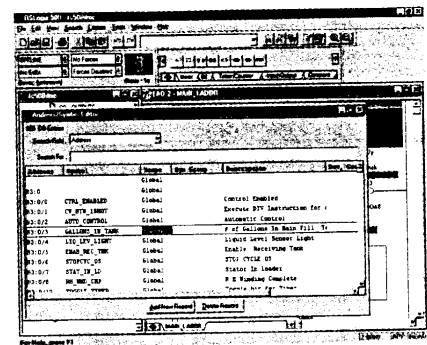

Powerful Database Editor

Diagnostics and Troubleshooting Tools

Simultaneously examine the status of bits, timers, counters, inputs, and outputs all in one window with the *Custom Data Monitor*. Each application project you create can have its own *Custom Data Monitor* window.

Easily review status bit settings specific to your application programming including *Scan Time* information, *Math Register* information, Interrupt settings and more with the tabbed *Status* displays.

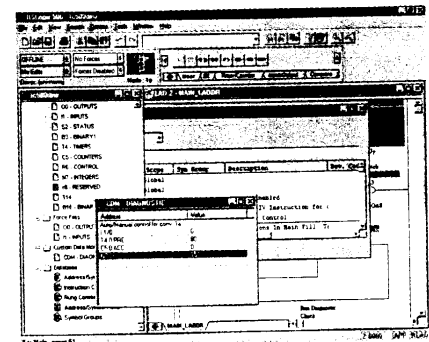

Diagnostics and Troubleshooting Tool

Selection Chart

Catalog Number	Description
9324-RL0300ENE ^{(1) (2)}	RSLogix 500 Programming for the MicroLogix families and SLC 500 on CD-ROM. Includes RSLinx Lite.
9324-RL0100ENE ^{(1) (2)}	RSLogix 500 Starter Programming for the MicroLogix families and SLC 500 on CD-ROM. This package is a functionally limited version of RSLogix 500.
Programming Cables	See page 22 for information on MicroLogix 1200 programming cables.

(1) To use RSLogix 500 programming software, your system must be a Pentium 100 MHz or higher, Windows® 95, Windows® 98, or Windows NT™.
 (2) Also available in French, German, Italian, Spanish and Portuguese.

Programming Instructions

The following table shows the MicroLogix 1200 instruction set listed within their functional groups.

Functional Group	Description
Relay-Type (Bit)	The relay-type (bit) instructions monitor and control the status of bits. XIC, XIO, OTE, OTL, OTU, OSR, ONS, OSF
Timer and Counter	The timer and counter instructions control operations based on time or the number of events. TON, TOF, RTO, CTU, CTD, RES
Compare	The compare instructions compare values by using a specific compare operation. EQU, NEQ, LES, LEQ, GRT, GEQ, MEQ, LIM
Math	The math instructions perform arithmetic operations. ADD, SUB, MUL, DIV, NEG, CLR, SQR, SCL, SCP
Conversion	The conversion instructions multiplex and de-multiplex data and perform conversions between binary and decimal values. DCD, ENC, TOD, FRD
Logical	The logical instructions perform bit-wise logical operations on words. AND, OR, XOR, NOT
Move	The move instructions modify and move words. MOV, MVM
File	The file instructions perform operations on file data. COP, FLL, BSL, BSR, FFL, FFU, LFL, LFU
Sequencer	Sequencer instructions are used to control automatic assembly machines that have consistent and repeatable operations. SQC, SQO, SQL
Program Control	The program flow instructions change the flow of ladder program execution. JMP, LBL, JSR, SBR, RET, SUS, TND, MCR, END
Input and Output	The input and output instructions allow you to selectively update data without waiting for the input and output scans. IIM, IOM, REF
User Interrupt	The user interrupt instructions allow you to interrupt your program based on defined events. STS, INT, UID, UIE, UIF
Process Control	The process control instruction provides closed-loop control. PID
Communications	The communication instructions read or write data to another station. MSG, SVC
High-Speed Counter	The high-speed counter instructions configure, control and monitor the controller's hardware counter. HSL, RAC
ASCII	The ASCII instructions use the communication channel for receiving or transmitting data and manipulate string data. ACL, AWA, AWT, AIC

Operator Interface Devices

Operator interface devices provide you with powerful plant floor control and data monitoring capabilities.

MicroView™ Operator Interface

The MicroView Operator Interface is a feature-packed, cost-effective operator interface designed for data monitoring, data display, data entry, and recipe download. This device features a 2-line x 16-character display window.

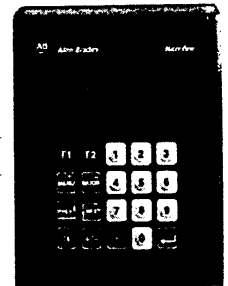

DTAM™ Micro Operator Interface

The DTAM Micro Operator interface provides another operator interface to the MicroLogix line. DTAM Micro is a low-cost operator interface. This device features a 2-line x 20-character display window. Up to 244 application screens can be stored in memory.

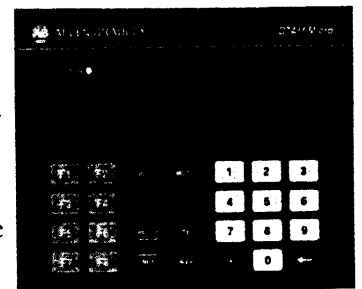

21

DTAM Plus Operator Interface

The DTAM Plus Operator Interface provides a highly functional operator interface for the MicroLogix 1200 family of processors. This device features a 4-line x 20-character display window for viewing data table information and operator prompts. Display screens are created using an Offline Development software Package.

PanelView™ Operator Terminals

PanelView Operator Terminals provide operator interface capabilities in space saving, flat panel designs or 14-inch CRTs. These electronic operator interfaces feature pixel graphics and high-performance functionality in color and monochrome flat panel displays, as well as Super VGA CRTs with optimum viewing angles and resolution. PanelView terminals provide extensive diagnostic information to operators during fault conditions through message windows, alarm windows, and simple graphics.

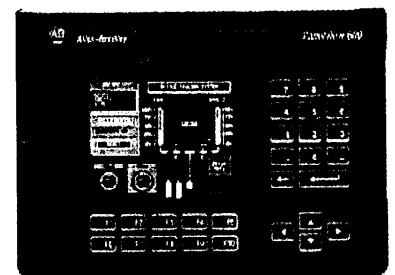

Accessories

Real-Time Clock (1762-RTC)

- Optional real-time clock module allows for time/date scheduling applications to be easily solved.

Memory Modules (1762-MM1, 1762-MM1RTC)

- Memory backup and real-time clock/memory module
- User Program and Data Back-up
- Program Compare
- Data File Protection
- Memory Module Write Protection
- Removal/Insertion Under Power

Cables

Use the communication cables listed below with MicroLogix 1200 controllers. Cables come in several lengths and connector styles to provide connectivity to the MicroLogix family of products.

Catalog Number	Cable Type	Description
1761-CBL-AM00	8-pin DIN to 8-pin DIN	This 45 cm (17.7 in.) cable is used to connect the MicroLogix controller to port 2 of the 1761-NET-AIC
1761-CBL-HM02	8-pin DIN to 8-pin DIN	This 2m (6.56 ft) cable is used to connect the MicroLogix 1200 Programmable Controller to the HHP or to connect any MicroLogix Programmable Controller to port 2 of the 1761-NET-AIC
1761-CBL-AP00	9-pin D-shell to 8-pin DIN	This 45cm (17.7 in.) cable is used to connect a MicroLogix controller to port 1 of the 1761-NET-AIC.
1761-CBL-PM02	9-pin D-shell to 8-pin DIN	This 2m (6.56 ft) cable is used to connect the MicroLogix Programmable Controller to an IBM compatible PC or to connect an IBM compatible PC to port 2 of the 1761-NET-AIC

NOTE

Series C or later cables are required for use with MicroLogix 1200 controllers.

User Documentation

For an introduction to micro PLC's refer to the MicroMentor™, Publication 1761-MMB. The MicroMentor book includes illustrations, sample applications you can put to immediate use, step-by-step strategies, and worksheets.

Additionally, MicroLogix 1200 user documentation presents information according to the tasks you perform and the programming environment you use. Refer to the table below for information on MicroLogix 1200 and related publications.

See this Document	Publication Number
MicroLogix™ 1200 Programmable Controllers Installation Instructions	1762-IN006A-US-P
MicroLogix™ 1200 Programmable Controllers User Manual	1762-UM001A-US-P
MicroLogix™ 1200 and MicroLogix™ 1500 Instruction Set Reference Manual	1762-RM001A-US-P
MicroLogix™ 1200 Real-Time Clock and Memory Module Installation Instructions	1762-IN001A-US-P
AIC+ Advanced Interface Converter and DeviceNet Interface Installation instructions	1761-5.11
AIC+ Advanced Interface Converter User Manual	1761-6.4
DeviceNet™ Interface User Manual	1761-6.5
DTAM™ Micro Operator Interface Module User Manual	2707-803
MicroView™ Operator Interface Module User Manual	2707-805
DataDisc™ CD-ROM Information Library	1795-CDRS and 1795-CDRL

23

For assistance selecting the correct MicroLogix Programmable Controller for your application, see the MicroLogix selector guide on the back of this publication. If you would like a system overview for the MicroLogix 1000 or MicroLogix 1500 controllers, refer to the following table.

See this Document	Publication Number
MicroLogix™ 1000 System Overview	1761-S0001A-US-P
MicroLogix™ 1500 System Overview	1764-S0001A-US-P

To purchase a manual or download a free electronic version, visit us at <http://www.theautomationbookstore.com>. Or, for fast access to Bulletin 1761, 1762, and 1764 publications, visit the MicroLogix Internet site <http://www.ab.com/micrologix>. Electronic versions of our manuals are available for you to search and download.

Dimensions

Dimensions Drawings

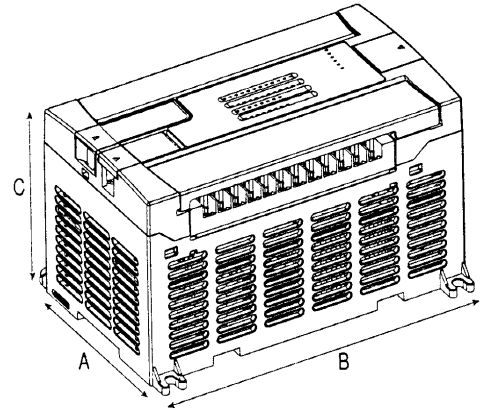

1762-L40AWA, 1762-L40BWA

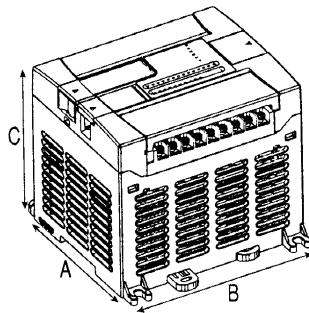

1762-L24AWA, 1762-L24BWA

Dimension	1762-L24AWA	1762-L24BWA	1762-L40AWA	1762-L40BWA
A	90 mm (3.5 in.)		90 mm (3.5 in.)	
B	110 mm (4.33 in.)		160 mm (6.30 in.)	
C	87 mm (3.43 in.)		87 mm (3.43 in.)	

MicroLogix 1200 I/O System

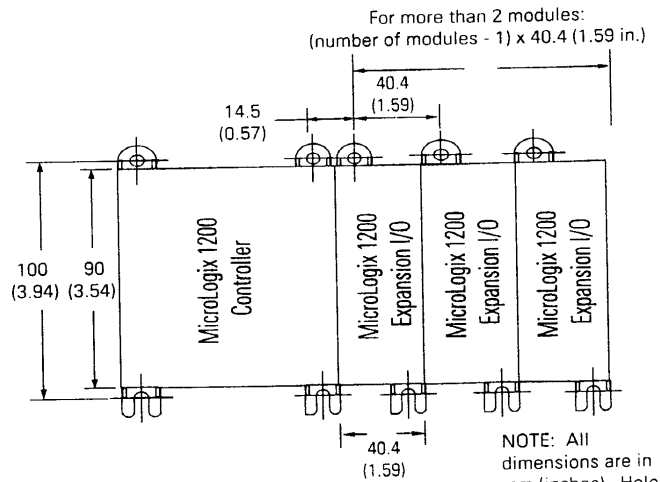

NOTE: All dimensions are in mm (inches). Hole spacing tolerance: +/- 0.4 mm (0.016 in.).