

# HC-B 10-AML - Housing

1771338

<https://www.phoenixcontact.com/il/products/1771338>



Please be informed that the data shown in this PDF document is generated from our online catalog. Please find the complete data in the user documentation. Our general terms of use for downloads are valid.

HEAVYCON B10 panel mounting base, with single locking latch, height: 29 mm, with flat gasket



## Commercial data

Item number	1771338
Packing unit	10 pc
Minimum order quantity	1 pc
Product key	BF7AAC
Catalog page	Page 496 (C-4-2013)
GTIN	4017918036065
Weight per piece (including packing)	100.58 g
Weight per piece (excluding packing)	91.9 g
Customs tariff number	85389099
Country of origin	DE

# HC-B 10-AML - Housing

1771338

<https://www.phoenixcontact.com/il/products/1771338>

## Technical data

### Notes

General	For contact inserts HC-B10, BB18, DD42, M, K8/24
---------	--

### Product properties

Type	B10
Product type	Housing with locking latch
Housing type	Panel mounting base
Shielded	no
Pg screw connection	none

### Dimensions

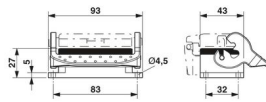
Dimensional drawing	
Width	43 mm
Height	29 mm
Length	93 mm

### Installation dimensions

Width of the assembly cutout	35 mm
Length of the assembly cutout	65 mm

### Material specifications

Seal material	NBR
	CR
Housing surface material	Powder-coated, gray
Locking latch material	Stainless steel, handle: PA
Housing material	die-cast aluminum

### Mechanical properties

#### Mechanical data

Locking type	Latch
--------------	-------

### Environmental and real-life conditions

#### Ambient conditions

Degree of protection	IP65 (When plugged in)
Ambient temperature (operation)	-40 °C ... 125 °C

# HC-B 10-AML - Housing

1771338

<https://www.phoenixcontact.com/il/products/1771338>



Phoenix Contact 2024 © - all rights reserved

<https://www.phoenixcontact.com>

PHOENIX CONTACT Israel Ltd.  
P.O.B. 1799 Industrial Park Hasharon  
Quadima 60920  
+972-9-8915700  
[info@phoenixcontact.co.il](mailto:info@phoenixcontact.co.il)