

## NEMA Motor Data



Ordering data : **1LE2221-4BB21-2AA3**

Client order no. :  
 Order no. :  
 Offer no. :  
 Remarks :

Item no. :  
 Consignment no. :  
 Project :

Nameplate Data	Mounting and motor protection
----------------	-------------------------------

Type	GP100 - NEMA Premium Efficiency		
HP	100.0	Rating	Cont.
Voltage	(12) 460V STD, 60Hz	Ins. Class	Class F (Standard)
Amps	113.0 A	S.F.	1.15
FL RPM	1780	Amb. Temp.	40 deg C
FL Efficiency	95.4 %	Temp. Rise	Class B
FRAME	405TS	kVA Code	G
DE AFBMA	80BC03JP30	NEMA Des	B
ODE AFBMA	70BC02JPP30	Mtr WT	1107.02
60 Hertz	3 Ph	TEFC	IP 54

Type of construction	( A ) Foot mounted - End shield
Motor protection	(A) No winding protection
Terminal box design	(3) Mounting - F-1

Bearing Data		
--------------	--	--

	DE	ODE
Bearing Size	6316 Z C3 S0	6214 ZZ C3 S0
Bearing Type	Ball Bearing	Ball Bearing
AFBMA	80BC03JP30	70BC02JPP30

Typical Performance Data					
--------------------------	--	--	--	--	--

Load	No Load	1/2	3/4	Full Load	LRC
Efficiency		95.8 %	96.0 %	95.4 %	
Power Factor		80.0	86.0	87.0	
Current (A)	30.0 A	61.1 A	85.1 A	113.0 A	725.0 A
Inverter Duty	VT	20:1	CT	n/a	

Mechanical Data				
-----------------	--	--	--	--

SAFE STALL TIME	HOT (s)	25	COLD (s)	35
Rtr wt (lbs)	301.29	Rtr WK2	23.4	
FLT (lb-ft)	295.000	LRT	180	BDT 200
Ext Load Inertia (WK2) Capability	105.0 lb-ft <sup>2</sup>			

Typical Noise Data										
--------------------	--	--	--	--	--	--	--	--	--	--

A-weighted Sound	Octave Band Center Frequencies Hertz (Hz)									
Pressure Level	125	250	500	1000	2000	4000	8000	SPL	67	
at 3 feet	44	57	61	62	60	59	48	SPwrL	77	

Wiring Connection Information					
-------------------------------	--	--	--	--	--

Description	3 PHASE - 3 LEAD - DELTA				
Voltage	L1	L2	L3	Connected together	
-----	-----	-----	-----	-----	-
-----	T1	T2	T3	-----	Δ

Special design :
------------------

Lubrication Information	
-------------------------	--

Manufacturer	Mobil Polyrex EM or equal
Type	Polyurea (standard)
DE Capacity (oz.)	7.50
ODEnd Capacity (oz.)	6.70

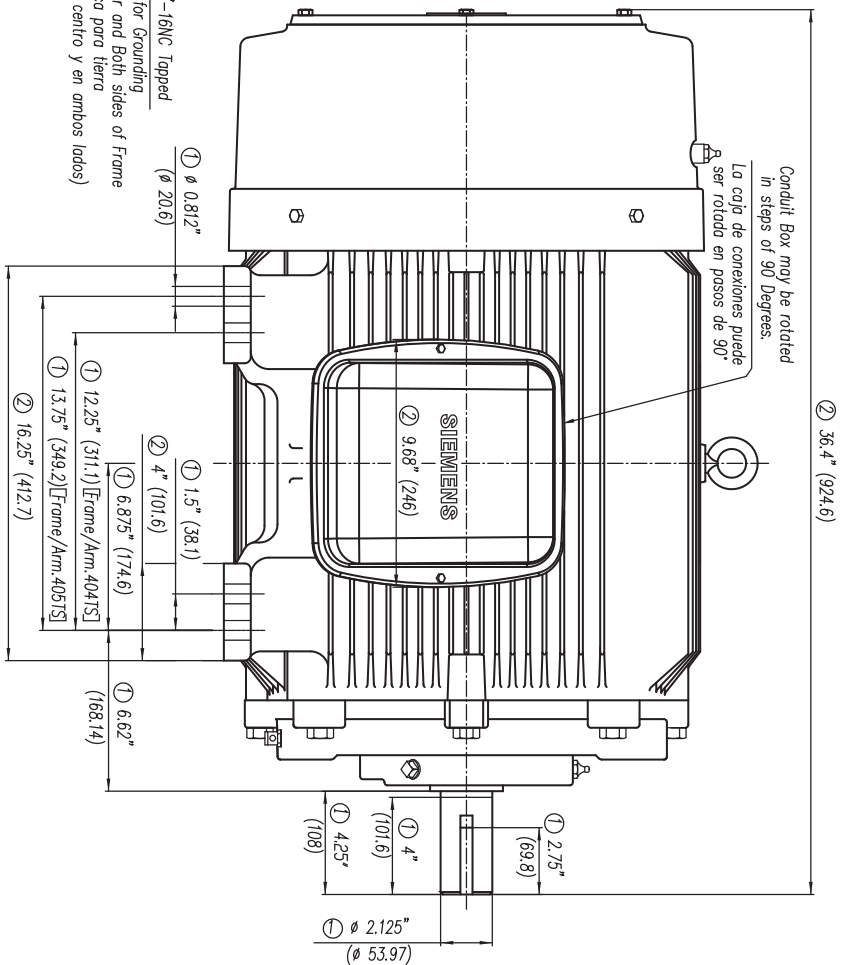
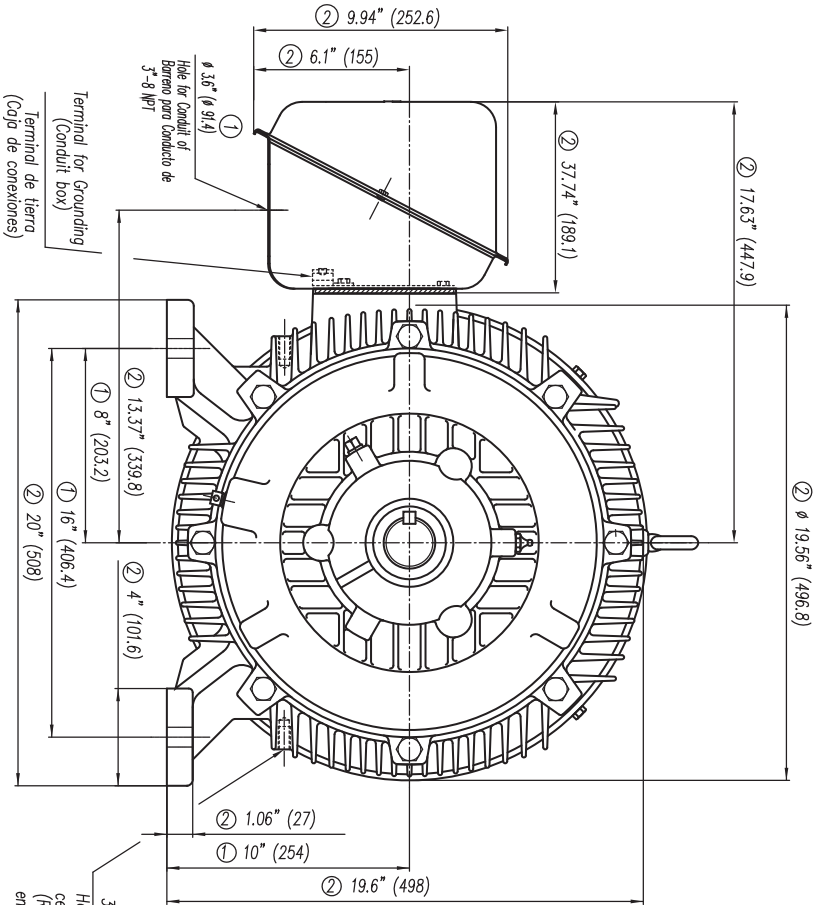

- ① Tolerances According to NEMA Std.
- ② All these dimensions corresponding to assemblies and castings shall have a tolerance as per DIN standard 1686-GTB-19.
- ③ Not According to NEMA Std.

- ① Tolerancias acorde a NEMA Std.
- ② Todos estas dimensiones correspondientes a ensambles y fundición en bruto tendrán una tolerancia según DIN 1686-GTB-19.
- ③ No Acorde a NEMA Std.

CERTIFIED PRINT/CERTIFICACION			
CUSTOMER/CLIENTE			
PROY/PROEN COMP/MA	SIW/SIWIEN CLIENTE/F		
RP	RPN	FRAME/ARMA	TYPE/TIPO
		VALIS	PHV/FAS
			HZ

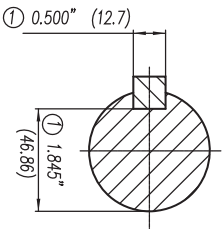

Keyseat detail  
Detalle Cuñero

Tol. in mm. acc. to/Tol. en mm. según DIN-1686-GTB-19	18	± 4.5
18	± 4.7	
30	± 5	
50	± 5.5	
80	± 6	
120	± 6.5	
180	± 7	
250	± 7.5	
315	± 8	
400	± 8.5	
500	± 9.5	
630	± 10	

European Projection/Proyección Europea	Modific.
Dim. in inches/Dim. en pulg.	
Drawn/Elab. 08/04/10	A. Perez
Check/Rev. 08/04/10	A. Real
Stad/Ord/Art	

**SIEMENS**  
GUADALAJARA FACTORY

Outline/Dimensiones  
New NEMA Motors (TS) Short Shaft/ Espiga Corta  
Type/ Tipo: GP10 Y GP100 404/405TS FRAME (Foot & mIP)

3MSE 740 0605 a)

Scale/Escala: W/O Sin

Ref.: 3MSE 740 0605

# SIEMENS INDUSTRY INC.

HP 100    VOLTS < 600V    RPM 1800    TYPE GP100  
HZ 60    PHASE 3    FRAME 405TS    NEMA B

## TORQUE & CURRENT VS. SPEED

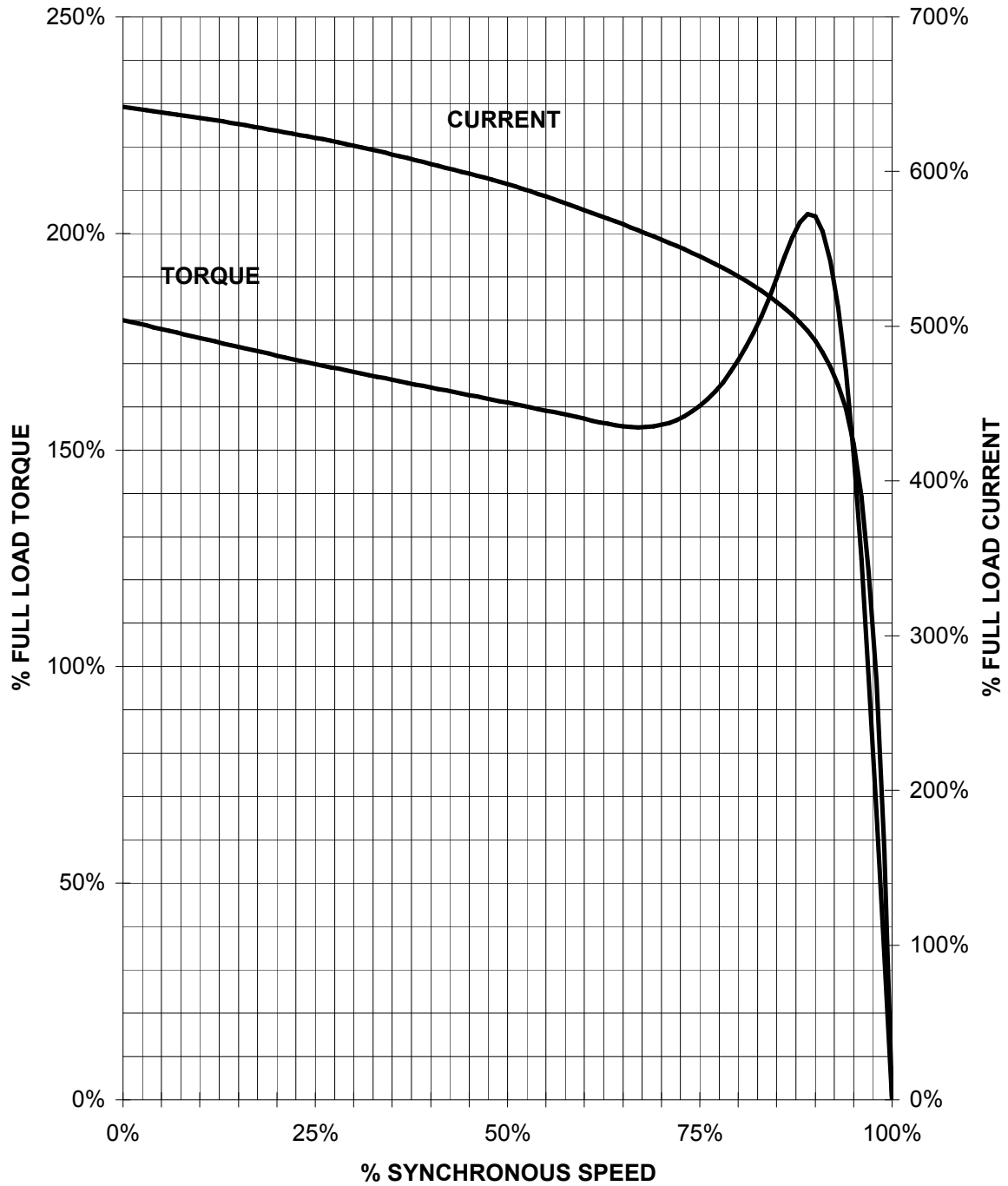

CUSTOMER: \_\_\_\_\_ ORDER#: \_\_\_\_\_

100 HP 1800 RPM 405TS FRAME 460 VOLTS 3 PHASE NEMA DESIGN B

**SIEMENS INDUSTRY, INC.**  
**PERFORMANCE CURVE**  
**GP100**

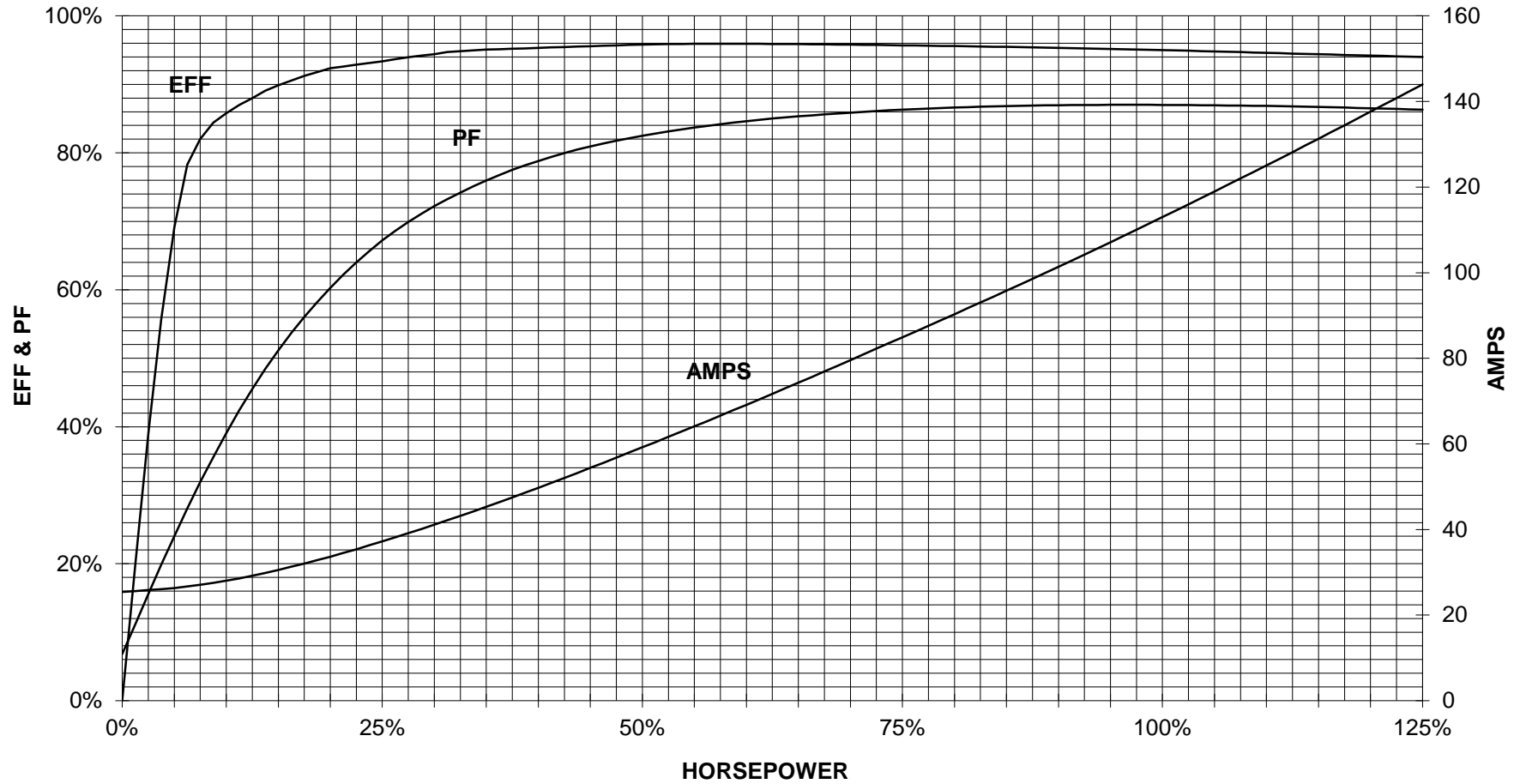

CUSTOMER \_\_\_\_\_ ORDER # \_\_\_\_\_ PO # \_\_\_\_\_

PERFORMANCE BASED ON DESIGN CALCULATIONS. SUBJECT TO CHANGE WITHOUT NOTICE.

REV. 1

2

1

### 3 PHASE - 3 LEADS - DELTA

L1	L2	L3	CONN.
T1	T2	T3	△

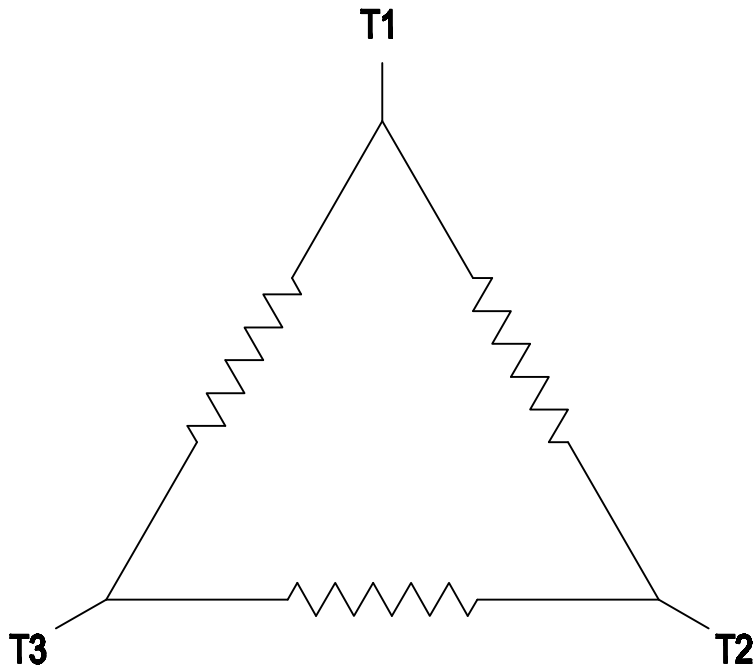

B

B

A

A

THIS IS A CAD DRAWING  
DO NOT MAKE MANUAL CHANGES

01 | 09-27-07

TYPE

-CONFIDENTIAL-

PROPERTY OF

Siemens Energy & Automation, Inc.  
Industrial Motor Division - Little Rock, AR

FRAME

HP

NAME

WIRING DIAGRAM

VOLTS

RPM

HZ

PH

3

Customer

DRAWN 9.24.07

DATE JRH

CHECKED

DATE

APP

DATE

SHEET

1 OF 1

Sim. To

PART NO.

51-382-114-504

A

2

1