

Main switch assembly kit, right side red

Part no. NZM3-XSR-R

Article no. 266658



Actuation of the switch on the control panel side wall

Switch mounting on mounting plate

Equipment supplied:

- Door coupling rotary handle
- NZM...-XV4 extension shaft
- External warning plate/designation label in German/English
- Black and yellow flash

For enhanced busbar tag shroud on the incomer side, IP2X protection against contact with a finger can be ordered, → 266744

Other external warning plates/designation labels can be clipped on.

Protection type IP66/UL/CSA Type 4x, Type 12

Delivery programme

Equipment supplied			Door coupling rotary handle with rotary drive NZM...-XV4 extension shaft External warning plate/marketing plate in German/English Black and yellow lightning symbol
Function			Red-yellow for emergency switching off
Protection class			IP66 UL/CSA Type 4X, Type 12
Locking facility			lockable on the 0 position on the handle using up to 3 padlocks
Project planning information			External warning plate/designation label can be clipped on. For enhanced busbar tag shroud on the incomer side, please order IP2X protection against contact with a finger.
Actuation			Actuation on the right
For use with			NZM3(-4) PN3(-4), N(S)3(-4)

Approbationen

Product Standards	UL489; CSA-C22.2 No. 5-09; IEC60947, CE marking
UL File No.	E140305
UL CCN	DIHS
CSA File No.	022086
CSA Class No.	1437-01
NA Certification	UL Listed, CSA certified
Degree of Protection	IEC: IP66, UL/CSA Type 4X, 12

Technische Daten nach ETIM 4.0

Suitable for switch-disconnector			YES
Suitable for circuit-breakers			YES
With shaft			YES
Suitable for emergency switching off			YES
Lockable			YES
Color			red

Dimensions

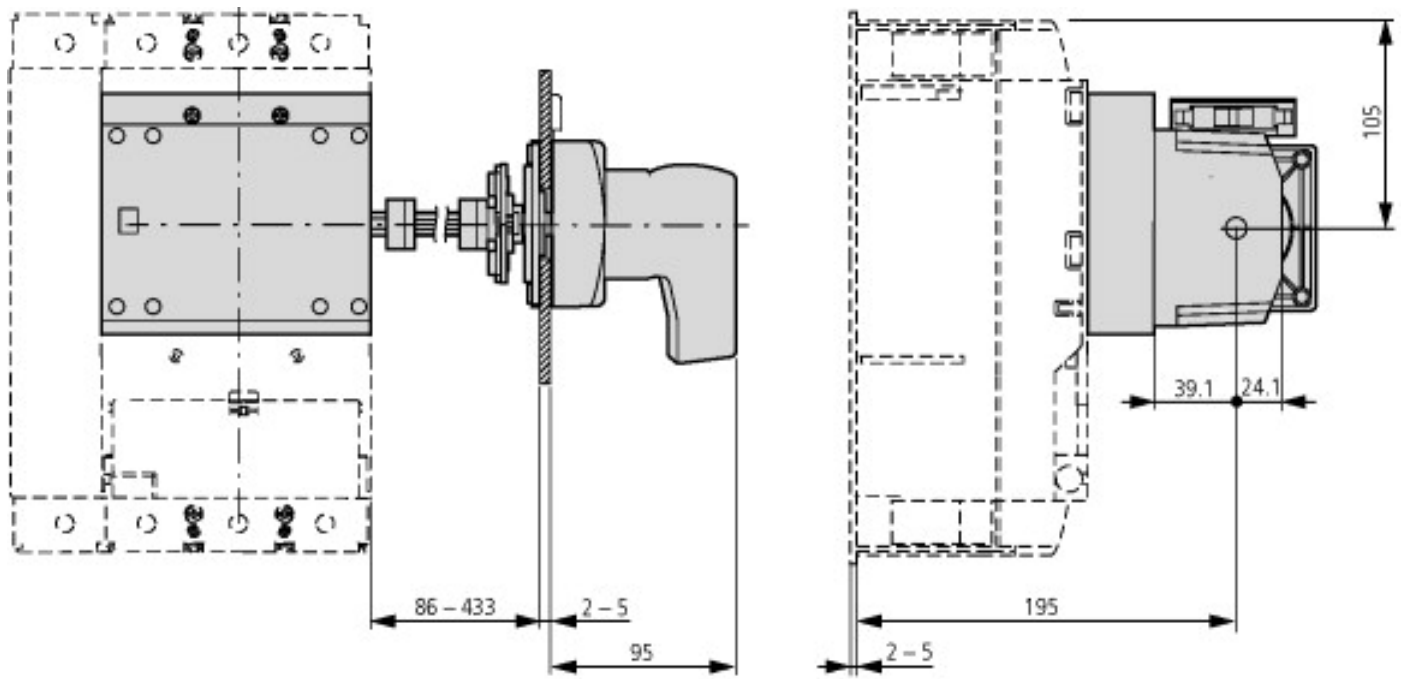

NZM3-XS(R)-L

Additional product information (links)

AWA1230-2116 (IL01219020Z) Flange operator NZM3

ftp://ftp.moeller.net/DOCUMENTATION/AWA_INSTRUCTIONS/21160903.pdf