

FL SWITCH 2206-2FX SM - Industrial Ethernet Switch



2702331

<https://www.phoenixcontact.com/cn/products/2702331>

Please be informed that the data shown in this PDF document is generated from our online catalog. Please find the complete data in the user documentation. Our general terms of use for downloads are valid.



Managed Switch 2000, 6 RJ45 ports 10/100 Mbps, 2 SC single mode 100 Mbps, PROFINET Conformance-Class B, Extended temperature range

Your advantages

- DHCP client, DHCP server (pool-based and port-based), DHCP option 82
- RSTP
- Ambient temperature -40 °C ... 70 °C
- VLANs
- MRP (client and manager)
- Configuration memory
- Slim design
- Web-based management, SNMP
- Easy and fast startup and commissioning with the FL NETWORK MANAGER software
- Suitable for PROFINET and EtherNet/IP™ networks

Commercial data

| | |
|--------------------------------------|---------------------|
| Item number | 2702331 |
| Packing unit | 1 pc |
| Minimum order quantity | 1 pc |
| Sales key | DNN121 |
| Product key | DNN121 |
| Catalog page | Page 309 (C-6-2019) |
| GTIN | 4055626136486 |
| Weight per piece (including packing) | 429.8 g |
| Weight per piece (excluding packing) | 260 g |
| Customs tariff number | 8517623200 |
| Country of origin | DE |

Technical data

Dimensions

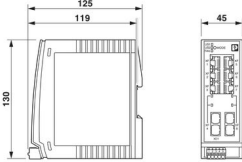
| | | |
|---------------------|--|--|
| Dimensional drawing |  | |
| Width | 45 mm | |
| Height | 130 mm | |
| Depth | 119 mm | |

Notes

| | |
|---------|--|
| General | Support by phone or on-site (fee is charged) |
|---------|--|

Material specifications

| | |
|------------------|--------------------------------|
| Housing material | Polycarbonate fiber reinforced |
|------------------|--------------------------------|

Mounting

| | |
|---------------|-------------------|
| Mounting type | DIN rail mounting |
|---------------|-------------------|

Interfaces

Ethernet (RJ45)

| | |
|-------------------------------|-----------------------------------|
| Connection method | RJ45 |
| Note on the connection method | Auto negotiation and autocrossing |
| Transmission speed | 10/100 Mbps |
| Transmission physics | Copper |
| Transmission length | 100 m (per segment) |
| Signal LEDs | Data receive, link status |
| No. of channels | 6 (RJ45 ports) |

Ethernet FO

| | |
|------------------------------|--|
| Number of interfaces | 2 |
| Connection method | SC |
| Transmission speed | 100 Mbps (full duplex) |
| Transmit capacity, minimum | -15 dBm |
| Transmit capacity, maximum | -7 dBm |
| Minimum receiver sensitivity | -34 dBm |
| Maximum receiver sensitivity | -3 dBm |
| Transmission physics | Single-mode fiberglass |
| Transmission length | 36000 m (fiberglass with F-G 9/125 0.36 dB/km) |
| | 32000 m (fiberglass with F-G 9/125 0.4 dB/km) |

2702331

<https://www.phoenixcontact.com/cn/products/2702331>

| | |
|-----------------|---|
| | 26000 m (fiberglass with F-G 9/125 0.5 dB/km) |
| Wavelength | 1300 nm |
| Signal LEDs | Data receive, link status |
| No. of channels | 2 (SC single mode) |

Output data

Digital

| | |
|-------------|--------------|
| Output name | Alarm output |
|-------------|--------------|

Product properties

| | |
|--------------------|---|
| Type | Book type |
| Product type | Switch |
| Product family | Managed Switch 2000 |
| MTTF | 343.16 Years (SN 29500 standard, temperature 25°C, operating cycle 21%) |
| | 153.37 Years (SN 29500 standard, temperature 40°C, operating cycle 34.25%) |
| | 18.66 Years (SN 29500 standard, temperature 70°C, operating cycle 100%) |
| Special properties | Extended temperature range |
| Signal delay | ≥ 6.5 μs (Store and Forward mode, 10/100 Mbps, depending on the frame size) |

Insulation characteristics

| | |
|---------------------|----------------|
| Protection class | III (VDE 0106) |
| Degree of pollution | 2 |

Switch functions

| | |
|--------------------------------|--|
| Diagnostic functions | RMON History |
| | LLDP (Link Layer Discovery Protocol) |
| | SNMP-Traps |
| | N:1-Portmirroring |
| | ACD (Address Conflict Detection) |
| | SysLog |
| | CRC-Surveillance |
| Basic functions | Store-and-forward switch, complies with IEEE 802.3 |
| Signal contact control voltage | typ. 24 V DC |
| PROFINET conformance class | Conformance-Class B |
| PROFINET device function | PROFINET device |
| | Fast Startup |
| Filter functions | Quality of Service (8 priority classes) |
| | Class of Service |
| | DiffServ/DSCP |
| | Port-Priorisierung |
| | VLAN (up to 32 VLANs) |
| | IGMP Snooping/Querier (v1/v2) |

| | |
|----------------------------------|---|
| | Auto-Query-Port |
| | Extended Multicast Filtering |
| IP parameterization | DHCP-Client |
| | DHCP Option 82 (Relay Agent) |
| | DHCP server (pool-based, port-based) |
| | BootP |
| | DCP (Discovery and Configuration Protocol) |
| MAC address table | 8k |
| Management | Web-based management (HTTP/HTTPS) |
| | Role-based user management (LDAP, RADIUS) |
| | SNMPv1/v2/v3 |
| | Command Line Interface (Telnet, SSH) |
| Redundancy | MRP (Media Redundancy Protocol) |
| | RSTP (Rapid Spanning Tree Protocol) |
| | FRD (Fast Ring Detection) |
| | Large Tree Support |
| | LACP (Link Aggregation Control Protocol) |
| | PROFINET S2 system redundancy |
| Status and diagnostic indicators | LEDs: US1, US2 (power supply), Fail (alarm contact), 2 LEDs per Ethernet port (Link/Activity and Speed) |
| Additional functions | Transmission of MMS and GOOSE (IEC 61850-8-1) |
| | Transmission of Modbus/TCP |
| Time synchronization | SNTP (Simple Network Time Protocol) |
| Security functions | |
| Port security | MAC-based, RADIUS (IEEE 802.1X), MAC Authentication Bypass |
| Basic functions | Store-and-forward switch, complies with IEEE 802.3 |

Electrical properties

| | |
|---|---|
| Local diagnostics | US1/2 Supply voltage US1, US2 Green LED |
| | FAIL Div. LED red |
| | LINK Link status Green LED |
| Maximum power dissipation for nominal condition | 6.75 W ($U_S = \text{Min}$, $T_{\text{amb}} = \text{Max}$, $DO_1 = \text{Max}$) |
| Test voltage | 500 V DC |
| Test section | for one minute 500 V DC |
| Transmission medium | Copper |
| | FO |

Supply

| | |
|--------------------------|--|
| Supply voltage (DC) | 24 V DC (redundant) |
| Supply voltage range | 9 V DC ... 57 V DC |
| Power supply connection | via COMBICON, max. conductor cross section 1.5 mm ² |
| Residual ripple | 3.6 V _{pp} (within the permitted voltage range) |
| Max. current consumption | 1.5 A ($U_S = \text{Min}$, $T_{\text{amb}} = \text{Max}$, $DO_1 = \text{Max}$) |

FL SWITCH 2206-2FX SM - Industrial Ethernet Switch



2702331

<https://www.phoenixcontact.com/cn/products/2702331>

| | |
|-----------------------------|---|
| Typical current consumption | 235 mA (at $U_S = 24$ V DC and 25 °C ambient temperature) |
| Current consumption | 260 mA |

Function

| | |
|--------------------------------|--------------|
| Signal contact control voltage | typ. 24 V DC |
|--------------------------------|--------------|

Connection data

| | |
|-----------------------------------|---|
| Connection method | Push-in spring connection |
| Note on the connection method | Use only copper connecting cables providing the permitted temperature range (-40 °C ... 75 °C). |
| Conductor cross section, rigid | 0.25 mm ² ... 1.5 mm ² |
| Conductor cross section, flexible | 0.25 mm ² ... 1.5 mm ² |
| Conductor cross section AWG | 24 ... 16 |
| Stripping length | 9 mm |

Environmental and real-life conditions

Ambient conditions

| | |
|--|---|
| Degree of protection | IP20 |
| Ambient temperature (operation) | -40 °C ... 70 °C |
| Ambient temperature (storage/transport) | -40 °C ... 85 °C |
| Permissible humidity (operation) | 10 % ... 95 % (non-condensing) |
| Permissible humidity (storage/transport) | 10 % ... 95 % (non-condensing) |
| Shock (operation) | 30g (EN 60068-2-27) |
| Vibration (operation) | in acc. with IEC 60068-2-6: 5g, 150 Hz |
| Air pressure (operation) | 80 kPa ... 110 kPa up to 2000 m above mean sea level (Without derating) |
| Air pressure (storage/transport) | 79 kPa ... 108 kPa up to 2000 m above mean sea level (Without derating) |

Standards and regulations

| | |
|---|-----|
| Free from substances that could impair the application of coating | Yes |
|---|-----|

Approvals

| | |
|-----------------------|--|
| Shipbuilding approval | Tested in accordance with IEC 60945 and IACS E10 |
|-----------------------|--|

ATEX

| | |
|----------------|--------------------------|
| Identification | ⊕ II 3 G Ex ec IIC T4 Gc |
| Certificate | DEMKO 16 ATEX 1709X |

IECEX

| | |
|----------------|---------------------|
| Identification | Ex ec IIC T4 Gc |
| Certificate | IECEX ULD 16.0018 X |

UL, USA/Canada

| | |
|----------------|-------|
| Identification | cULus |
|----------------|-------|

UL Ex, USA / Canada

FL SWITCH 2206-2FX SM - Industrial Ethernet Switch



2702331

<https://www.phoenixcontact.com/cn/products/2702331>

| | |
|----------------|---|
| Identification | Class I, Division 2, Groups A, B, C, and D, T4 |
| | Class I, Zone 2, AEx ec IIC T4 |
| | Ex ec IIC T4 Gc X |
| Certificate | E366272 |
| Note | UL 60079-0 Ed. 6 / UL 60079-7 Ed. 5, CSA 22.2 No. 60079-0 Ed. 3 / CSA C22.2 No. 60079-7 Ed. 2 |

EAC Ex

| | |
|----------------|-------------------------|
| Identification | 2Ex e IIC T4 Gc X |
| Certificate | RU C-DE.HB49.B.00118/21 |

The following continue to apply for EAC Ex:

| | |
|----------------|---|
| Identification | При монтаже использовать подходящий допущенный корпус со степенью защиты не ниже IP66. |
| | На корпусе/шкафу управления должна быть размещена предупреждающая надпись, запрещающая открывать корпус или шкаф во взрывоопасной зоне. |
| | Эксплуатация устройства допускается только при условии, что все оптические порты заняты подключенными устройствами или закрыты прилагаемыми заглушками. |

CCC / China-Ex

| | |
|----------------|------------------|
| Identification | Ex ec IIC T4 Gc |
| Certificate | 2022122310115629 |

Corrosive gas test

| | |
|----------------|----------------------------------|
| Identification | ISA S71.04.2013 G3 Harsh Group A |
|----------------|----------------------------------|

UKCA Ex (UKEX)

| | |
|----------------|--------------------------|
| Identification | ⊕ II 3 G Ex ec IIC T4 Gc |
| Certificate | PxCIMA22UKEX2702910X |

DNV GL data

| | |
|-------------|---|
| Temperature | B |
| Humidity | B |
| Vibration | A |
| EMC | B |
| Enclosure | Required protection according to the Rules shall be provided upon installation on board |

EMC data

| | |
|---------------------------------|--|
| Conformance with EMC directives | EN 61000-6-2 EN 61000-4-2 (ESD) Criterion B |
| | EN 61000-6-2 EN 61000-4-3 (electromagnetic fields) Criterion A |
| | EN 61000-6-2 EN 61000-4-4 (EFT burst) Criterion A |
| | EN 61000-6-2 EN 61000-4-5 (surge) Criterion A |
| | EN 61000-6-2 EN 61000-4-6 (line noise immunity) Criterion A |
| | EN 61000-6-2 EN 61000-6-4 (interference) Class A |
| | EN 61000-6-2 EN 61000-6-4 (conducted interference) Class A |
| Noise immunity | EN 61000-6-2 |

FL SWITCH 2206-2FX SM - Industrial Ethernet Switch



2702331

<https://www.phoenixcontact.com/cn/products/2702331>

| | |
|-------------------------------|---|
| Electromagnetic compatibility | Conformance with EMC Directive 2014/30/EU |
| Noise emission | EN 61000-6-4 |

System properties

Functionality

| | |
|-----------------|--|
| Basic functions | Store-and-forward switch, complies with IEEE 802.3 |
|-----------------|--|

Signaling

| | |
|----------------|---|
| Status display | LEDs: US1, US2 (power supply), Fail (alarm contact), 2 LEDs per Ethernet port (Link/Activity and Speed) |
|----------------|---|

FL SWITCH 2206-2FX SM - Industrial Ethernet Switch



2702331

<https://www.phoenixcontact.com/cn/products/2702331>

Drawings

Dimensional drawing

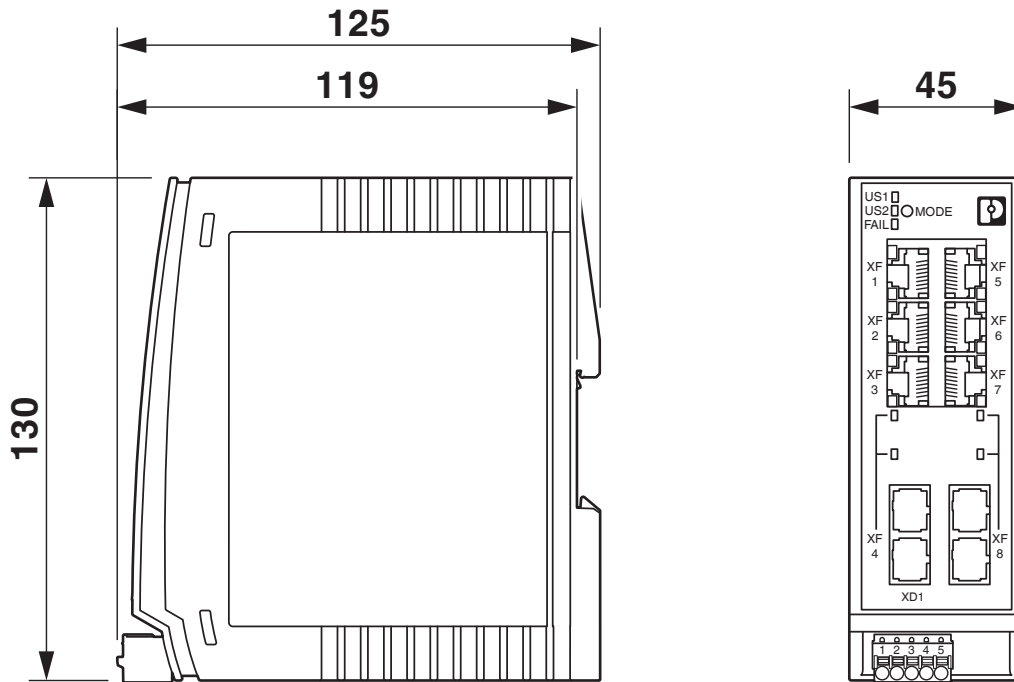

2702331

<https://www.phoenixcontact.com/cn/products/2702331>

Approvals

To download certificates, visit the product detail page: <https://www.phoenixcontact.com/cn/products/2702331>



EAC

Approval ID: RU*-DE.*.B.00741/19



DNV GL

Approval ID: TAA00000YV



LR

Approval ID: LR22250919TA



NK

Approval ID: TA19464M



BV

Approval ID: 48146/A1 BV

BSH

Approval ID: Nr. 966



RINA

Approval ID: ELE162721XG

ABS

Approval ID: 21-2066186-PDA

UAE-RoHS

Approval ID: 23-02-63230



cULus Listed

Approval ID: E238705



cUL Listed

Approval ID: FILE E 366272

FL SWITCH 2206-2FX SM - Industrial Ethernet Switch



2702331

<https://www.phoenixcontact.com/cn/products/2702331>



IECEx

Approval ID: IECEx ULD 16.0018X



ATEX

Approval ID: DEMKO 16 ATEX 1709X



CCC

Approval ID: 2022122310115629

FL SWITCH 2206-2FX SM - Industrial Ethernet Switch



2702331

<https://www.phoenixcontact.com/cn/products/2702331>

Classifications

ECLASS

| | |
|-------------|----------|
| ECLASS-11.0 | 19170401 |
| ECLASS-12.0 | 19170401 |
| ECLASS-13.0 | 19170401 |

ETIM

| | |
|----------|----------|
| ETIM 9.0 | EC000734 |
|----------|----------|

UNSPSC

| | |
|-------------|----------|
| UNSPSC 21.0 | 43222600 |
|-------------|----------|

2702331

<https://www.phoenixcontact.com/cn/products/2702331>

Environmental product compliance

| | |
|------------|--|
| REACH SVHC | Lead 7439-92-1 |
| China RoHS | Environmentally Friendly Use Period = 50 years |
| | For information on hazardous substances, refer to the manufacturer's declaration available under "Downloads" |

Phoenix Contact 2024 © - all rights reserved

<https://www.phoenixcontact.com>

菲尼克斯（中国）投资有限公司总部
南京市江宁经济开发区菲尼克斯路36号
（江宁236信箱）邮编：211100
025-52121888
phoenix@phoenixcontact.com.cn