

VAL-SQ SP 120-120/208Y/FM - Type 2 surge protection replacement module



2803904

<https://www.phoenixcontact.com/pc/products/2803904>

Please be informed that the data shown in this PDF document is generated from our online catalog. Please find the complete data in the user documentation. Our general terms of use for downloads are valid.

Surge protection device for 120/208 V AC Wye configurations. Uses a compact, NEMA rated enclosure that connects easily to an existing enclosure. Hybrid Sine Wave Tracking provides 120 kA surge protection.



Commercial data

Item number	2803904
Packing unit	1 pc
Minimum order quantity	1 pc
Product key	CL1612
Catalog page	Page 70 (TT-2009)
GTIN	4046356316125
Weight per piece (including packing)	2.883 kg
Weight per piece (excluding packing)	2.883 kg
Customs tariff number	85363030
Country of origin	US

VAL-SQ SP 120-120/208Y/FM - Type 2 surge protection replacement module



2803904

<https://www.phoenixcontact.com/pc/products/2803904>

Technical data

Product properties

IEC test classification	I + II
Type	Parallel MOV
Surge protection fault message	Phase LEDs
	Audible alarm
	Remote indication contact

Electrical properties

General

Power Systems	120/208 V AC Wye
---------------	------------------

Connection data

Connection method	#10 AWG/5.26 mm ² wires (24 in./61 cm long)
Connection method	#24 AWG/0.205 mm ² wires (24 in./61 cm long)

Dimensions

Width	250 mm
Height	79 mm
Depth	122 mm

Cable/line

Cable length	61 cm
--------------	-------

Protective circuit

Direction of action	3L-N & N-GND
Maximum continuous voltage U_C	150 V
Response time t_A	< 1 ns

Environmental and real-life conditions

Ambient conditions

Degree of protection	IP66 / NEMA 4X
Ambient temperature (operation)	-40 °C ... 60 °C
Ambient temperature (storage/transport)	-40 °C ... 85 °C
Altitude	3658 m

Approvals

UL specifications

Short-circuit current rating (SCCR)	200 kA
UL type	type 2

VAL-SQ SP 120-120/208Y/FM - Type 2 surge protection replacement module



2803904

<https://www.phoenixcontact.com/pc/products/2803904>

Maximum Circuit Breaker	30 A
Maximum Surge Current per Phase	120 kA

Standards and regulations

Standards

Standards/regulations	UL 1449 2 nd edition, February 2007
	UL 1283
	IEEE C62.41
	IEEE C62.45

Mounting

Mounting type	3/4 inch NPT male
Mounting position	any

VAL-SQ SP 120-120/208Y/FM - Type 2 surge protection replacement module



2803904

<https://www.phoenixcontact.com/pc/products/2803904>

Drawings

Circuit diagram

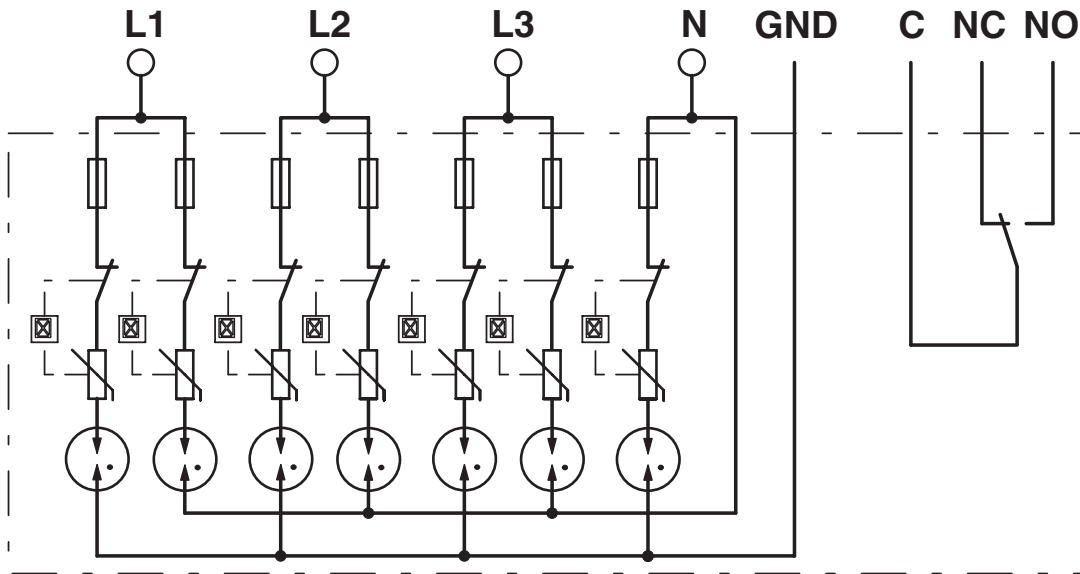

Phoenix Contact 2024 © - all rights reserved
<https://www.phoenixcontact.com>

PHOENIX CONTACT GmbH & Co. KG
Flachsmarktstraße 8
D-32825 Blomberg
+49 (0) 5235-3 00
info@phoenixcontact.com