

FL PA 3K4K 8 - Mounting panel



2891108

<https://www.phoenixcontact.com/no/products/2891108>

Please be informed that the data shown in this PDF document is generated from our online catalog. Please find the complete data in the user documentation. Our general terms of use for downloads are valid.

Mounting plate for FL SWITCH 30... and FL SWITCH 40... eight-port switches



Product description

The FL PA 3K4K 8 and FL PA 3K4K 16 mounting plates provide a method for mounting FL SWITCH 3000 and FL SWITCH 4000 switches to a flat panel surface in any orientation. Exception: The FL SWITCH 3000E switches need to be mounted with the ventilation holes on top. The plate can be mounted on either side of the switch to allow the network ports to face the proper direction. The plate mounts to the panel with user-supplied M6 or 1/4-inch hardware.

Your advantages

- Flexible panel mounting of FL SWITCH 3000 and 4000 series Ethernet managed switches
- Kit comes complete with screws need to mount the plate to the switch
- FL PA 3K4K 8: Allows panel mounting of 5- and 8-port Ethernet switches

Commercial data

Item number	2891108
Packing unit	1 pc
Minimum order quantity	1 pc
Sales key	31NDN1
Product key	DNN1ZZ
GTIN	4055626057804
Weight per piece (including packing)	305.2 g
Weight per piece (excluding packing)	305.2 g
Customs tariff number	76169990
Country of origin	TW

FL PA 3K4K 8 - Mounting panel

2891108

<https://www.phoenixcontact.com/no/products/2891108>



Technical data

Product properties

Product type	Assembly adapter
--------------	------------------

Dimensions

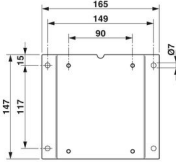
Dimensional drawing	
Width	165 mm
Height	147 mm

FL PA 3K4K 8 - Mounting panel

2891108

<https://www.phoenixcontact.com/no/products/2891108>



Drawings

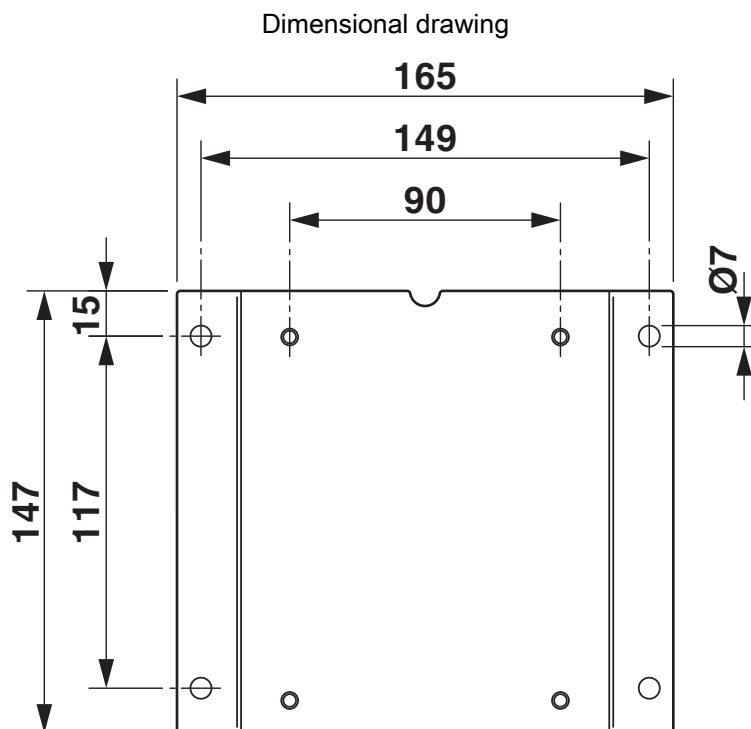

FL PA 3K4K 8 - Mounting panel

2891108

<https://www.phoenixcontact.com/no/products/2891108>



Classifications

UNSPSC

UNSPSC 21.0	39121421
-------------	----------

FL PA 3K4K 8 - Mounting panel



2891108

<https://www.phoenixcontact.com/no/products/2891108>

Environmental product compliance

China RoHS	Environmentally friendly use period: unlimited = EFUP-e
	No hazardous substances above threshold values

Phoenix Contact 2024 © - all rights reserved
<https://www.phoenixcontact.com>

PHOENIX CONTACT AS
Strømsveien 344
N-1081 Oslo
+47 22 07 68 00
norge@phoenixcontact.com