

ELR H51-IESSC-24DC500AC-06 - Hybrid motor starter



2902746

<https://www.phoenixcontact.com/us/products/2902746>

Please be informed that the data shown in this PDF document is generated from our online catalog. Please find the complete data in the user documentation. Our general terms of use for downloads are valid.



Short-circuit-proof hybrid motor starter for reversing 3~ AC motors up to 550 V AC, with 24 V DC input, 0.6 A output current, emergency stop function, and adjustable overload shutdown. Can only be used with EM-RD and EM-RI adapters or power distribution board.

Your advantages

- 22.5 mm wide
- Safety level in accordance with IEC 61508-1: SIL 3, ISO 13849: PL e
- Reduction in wiring
- Long service life
- Space saving
- Adjustable current for bimetal function
- Low-wear switching

Commercial data

Item number	2902746
Packing unit	1 pc
Minimum order quantity	1 pc
Sales key	C470
Product key	CK7452
Catalog page	Page 37 (C-5-2019)
GTIN	4046356673624
Weight per piece (including packing)	429 g
Weight per piece (excluding packing)	350 g
Customs tariff number	85371098
Country of origin	DE

ELR H51-IESSC-24DC500AC-06 - Hybrid motor starter



2902746

<https://www.phoenixcontact.com/us/products/2902746>

Set consists of

FUSE-10X38-16A-GR - Fuse

2903126

<https://www.phoenixcontact.com/us/products/2903126>



Fuse, number: 10 Pcs., fuse type: Fuse (CC), nominal current: 16 A, tripping characteristic: super-fast blow (gR)

Technical data

Product properties

Product type	Hybrid motor starters
Product family	CONTACTRON
Operating mode	100% operating factor

Electrical properties

Number of phases	3
Motor starter type	Reversing starter
Maximum power dissipation for nominal condition	1.7 W
Switching frequency	≤ 2 Hz (Load-dependent)
Maximum power dissipation	2.8 W
Minimum power dissipation	0.88 W
Coordination type	2

Supply

Rated control circuit supply voltage U_S	24 V DC
Control supply voltage range	19.2 V DC ... 30 V DC
Rated control supply current I_S	40 mA
Protective circuit	Surge protection
	Reverse polarity protection; Parallel polarity protection diode

Insulation characteristics

Rated insulation voltage	500 V
Rated surge voltage	6 kV
Overvoltage category	III
Degree of pollution	2
Insulation characteristics between the control input and control supply voltage, and auxiliary circuit to the main circuit	Safe isolation (IEC 60947-1) at operating voltage ≤ 300 V AC
	Basic insulation (IEC 60947-1) at operating voltage 300 V AC ... 500 V AC
Isolation characteristics between the control input and control supply voltage to auxiliary circuit	Safe isolation (IEC 60947-1) in the auxiliary circuit ≤ 300 V AC

Input data

Control

Input name	Control input right/left
Rated actuating voltage U_C	24 V DC
Triggering voltage range	19.2 V DC ... 30 V DC
Rated actuating current I_C	5 mA
Switching threshold	9.6 V ("0" signal)
	19.2 V ("1" signal)
Switching level	< 5 V DC (For EMERGENCY STOP)
Typical turn-off time	< 30 ms

Protective circuit	Reverse polarity protection
--------------------	-----------------------------

Output data

AC output

Rated operating voltage U_e	500 V AC
Operating voltage range	42 V AC ... 550 V AC
Mains frequency	50/60 Hz
Load current range	75 mA ... 600 mA (see to derating)
Trigger characteristic in acc. with IEC 60947-4-2	Class 10A
Cooling time	20 min. (for auto reset)
Leakage current	0 mA
Protective circuit	Surge protection; Varistor Short-circuit protection; Fuse

Acknowledge output

Note	Confirmation: floating change-over contact, signal contact
Contact switching type	1 changeover contact
Switching capacity in accordance with IEC 60947-5-1	3 A (230 V, AC15) 2 A (24 V, DC13)

Connection data

Control circuits

Connection method	Screw connection
Stripping length	8 mm
Screw thread	M3
Conductor cross section rigid	0.2 mm ² ... 2.5 mm ²
Conductor cross section flexible	0.2 mm ² ... 2.5 mm ²
Conductor cross section AWG	24 ... 14
Tightening torque	0.5 Nm ... 0.6 Nm 5 lb _f -in. ... 7 lb _f -in.

Load circuit

Connection method	Screw connection
Stripping length	8 mm
Screw thread	M3
Conductor cross section rigid	0.2 mm ² ... 2.5 mm ²
Conductor cross section flexible	0.2 mm ² ... 2.5 mm ²
Conductor cross section AWG	24 ... 14
Tightening torque	0.5 Nm ... 0.6 Nm 5 lb _f -in. ... 7 lb _f -in.

Signaling

Status display	Yellow LED
Operating voltage display	Green LED

Error indication	Red LED
------------------	---------

Dimensions

Width	22.5 mm
Height	160 mm
Depth	114.5 mm

Material specifications

Flammability rating according to UL 94	V0 (Housing)
--	--------------

Environmental and real-life conditions

Ambient conditions

Degree of protection	IP20
Ambient temperature (operation)	-25 °C ... 70 °C (observe derating)
Ambient temperature (storage/transport)	-40 °C ... 80 °C
Altitude	≤ 2000 m

Approvals

ATEX

Identification	⊕ II (2) G [Ex e] [Ex d] [Ex px]
	⊕ II (2) D [Ex t] [Ex p]
Certificate	PTB 12 ATEX 3004

UL approval

Certificate	NLDX.E228652
-------------	--------------

Safety Integrity Level (SIL, IEC 61508)

Identification	≤ 3
Note	Safe shutdown

Safety Integrity Level (SIL, IEC 61508)

Identification	2
Note	Motor protection

Performance Level (ISO 13849)

Identification	e
Note	Safe shutdown

Category (ISO 13849)

Identification	≤ 3
Note	Safe shutdown

CCC

Identification	GB/T 14048.6-2016
Certificate	2020970304000811

UL data

2902746

<https://www.phoenixcontact.com/us/products/2902746>

SCCR	100 kA (500 V AC (fuse: 30 A class CC/30 A class J (high fault)))
	5 kA (500 V AC (fuse: 20 A RK5 (standard fault)))
FLA	0.6 A (500 V AC)
Group installation	20 A (class RK5, SCCR 5kA, #24 - 14 AWG max. solid and stranded)
	30 A (class CC or J, SCCR 100kA, #24 - 14 AWG max, solid and stranded)
Category code	NLDX / NRNT

Standards and regulations

Standards/regulations

Standards/regulations	IEC 60947-1
	EN 60947-4-2
	IEC 61508
	ISO 13849

Mounting

Mounting type	Bus bar mounting
	DIN rail mounting
Assembly instructions	alignable, for spacing see derating
Mounting position	vertical (horizontal DIN rail, motor output below)

Drawings

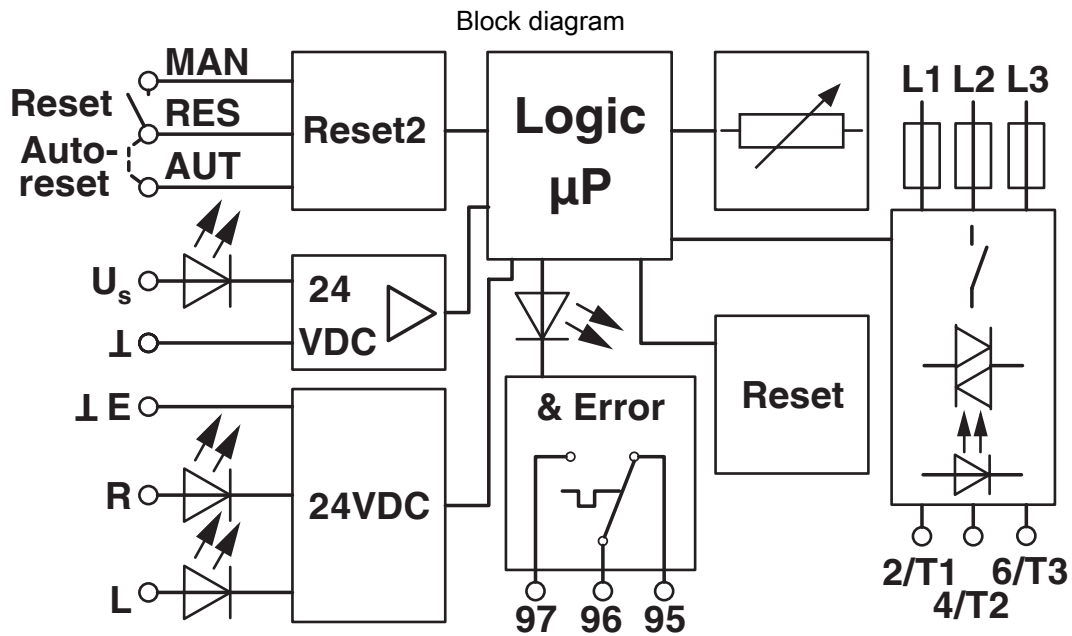

2902746

<https://www.phoenixcontact.com/us/products/2902746>

Approvals

To download certificates, visit the product detail page: <https://www.phoenixcontact.com/us/products/2902746>



IECEE CB Scheme

Approval ID: DE1-51298



EAC

Approval ID: RU*C-DE.*08.B.00520*



IECEE CB Scheme

Approval ID: DE1-60642



UL Listed

Approval ID: FILE E 228652



cUL Listed

Approval ID: FILE E 228652



ATEX

Approval ID: PTB 12 ATEX 3004

cULus Listed

2902746

<https://www.phoenixcontact.com/us/products/2902746>

Classifications

ECLASS

ECLASS-11.0	27370905
ECLASS-12.0	27370905
ECLASS-13.0	27370905

ETIM

ETIM 9.0	EC001037
----------	----------

UNSPSC

UNSPSC 21.0	25173900
-------------	----------

2902746

<https://www.phoenixcontact.com/us/products/2902746>

Environmental product compliance

REACH SVHC	Lead 7439-92-1
China RoHS	Environmentally Friendly Use Period = 50 years
	For information on hazardous substances, refer to the manufacturer's declaration available under "Downloads"

Phoenix Contact 2024 © - all rights reserved

<https://www.phoenixcontact.com>

Phoenix Contact USA
586 Fulling Mill Road
Middletown, PA 17057, United States
(+717) 944-1300
info@phoenixcon.com