

HMC 11 50DC 20A C1D2 - Hydraulic-magnetic circuit breaker



2907199

<https://www.phoenixcontact.com/in/products/2907199>

Please be informed that the data shown in this PDF document is generated from our online catalog. Please find the complete data in the user documentation. Our general terms of use for downloads are valid.

HMC series of supplemental circuit protector modules, 20 A rating



Your advantages

- Optional T-bus for reduced wiring
- UL recognized for hazardous locations Class I, Division 2, Groups A, B, C, and D
- Dual-rated for 50 V DC and 120 V AC
- Hydraulic-magnetic technology provides extended temperature stability

Commercial data

Item number	2907199
Packing unit	1 pc
Minimum order quantity	1 pc
Sales key	CLA
Product key	CLA181
GTIN	4055626342412
Weight per piece (including packing)	222.222 g
Weight per piece (excluding packing)	222.222 g
Country of origin	US

HMC 11 50DC 20A C1D2 - Hydraulic-magnetic circuit breaker



2907199

<https://www.phoenixcontact.com/in/products/2907199>

Technical data

Notes

Trade restriction

CE note	The products are offered exclusively for export outside the EU and the European Economic Area.
---------	--

Product properties

Product type	Device circuit breakers
Product family	HMC
Number of positions	4
Number of rows	1

Electrical properties

General

Nominal current I_N	20 A
Rated voltage	50 V DC
Rated short-circuit switching capacity I_{cn}	1 kA ()
Fuse	Hydraulic magnetic circuit breaker

Connection data

Screw thread	M3
Tightening torque	0.5 ... 0.6 Nm
Stripping length	7 mm
Conductor cross section rigid	0.2 mm ² ... 2.5 mm ²
Cross section AWG	24 ... 12 (converted acc. to IEC)
Conductor cross section flexible	0.2 mm ² ... 2.5 mm ²
Conductor cross section, flexible [AWG]	24 ... 12 (converted acc. to IEC)

Dimensions

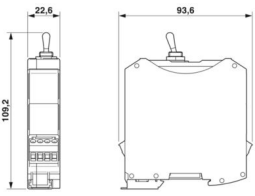
Dimensional drawing	
Width	22.6 mm
Height	93.6 mm
Depth	109.2 mm

Material specifications

Color	light grey (RAL 7035)
Material	Polyamide

HMC 11 50DC 20A C1D2 - Hydraulic-magnetic circuit breaker



2907199

<https://www.phoenixcontact.com/in/products/2907199>

Flammability rating according to UL 94	V0
--	----

Environmental and real-life conditions

Ambient conditions

Ambient temperature (operation)	-40 °C ... 65 °C
Ambient temperature (storage/transport)	-40 °C ... 65 °C

Standards and regulations

Standards/specifications	UL 1077
--------------------------	---------

Mounting

Mounting type	DIN rail: 35 mm
Mounting position	As desired on 35 mm DIN rail in acc. with EN 60715

Phoenix Contact 2024 © - all rights reserved
<https://www.phoenixcontact.com>

PHOENIX CONTACT (I) Pvt. Ltd.
A-58/2, Okhla Industrial Area, Phase - II, New Delhi-110 020

+91.1275.71420
info@phoenixcontact.co.in