

SK 14-D - Shield connection clamp

3026874

<https://www.phoenixcontact.com/au/products/3026874>

Please be informed that the data shown in this PDF document is generated from our online catalog. Please find the complete data in the user documentation. Our general terms of use for downloads are valid.



Shield connection terminal block, for direct shield on conductive mounting panels, sheet thickness 1 mm ... 2 mm

Your advantages

- Easy handling
- Spring-loaded, large-surface pressure plate
- Suitable for direct and busbar mounting
- Knurled screw
- As components, it is not possible to certify shield connections in accordance with the requirements of the directive and standards for electrical equipment in potentially explosive areas. As such, shield connection clamps can be used in the Ex area even without an appropriate approval or marking.

Commercial data

Item number	3026874
Packing unit	10 pc
Minimum order quantity	10 pc
Sales key	BE7511
Product key	BE7511
Catalog page	Page 568 (C-3-2019)
GTIN	4017918820268
Weight per piece (including packing)	18.5 g
Weight per piece (excluding packing)	18.48 g
Customs tariff number	85369010
Country of origin	DE

SK 14-D - Shield connection clamp

3026874

<https://www.phoenixcontact.com/au/products/3026874>

Technical data

Product properties

Product type	Shield connection clamp
Pitch	17 mm
Number of connections	1
Number of rows	1

Electrical properties

Maximum power dissipation for nominal condition	0.77 W
---	--------

Connection data

Grounding foot	Yes
Screw thread	M4
Tightening torque	0.8 ... 0.8 Nm

Dimensions

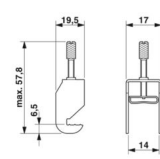
Dimensional drawing	
Width	17 mm
Height	19.5 mm
Depth	57.8 mm
Pitch	17 mm

External dimensions

Outside diameter	3 mm ... 14 mm
------------------	----------------

Material specifications

Color	silver
Material	Steel

Cable/line

External cable diameter	3 mm ... 14 mm
-------------------------	----------------

Mechanical properties

Mechanical data

Open side panel	No
-----------------	----

Mounting

Mounting type	direct screw connection
---------------	-------------------------

SK 14-D - Shield connection clamp

3026874

<https://www.phoenixcontact.com/au/products/3026874>



Drawings

Dimensional drawing

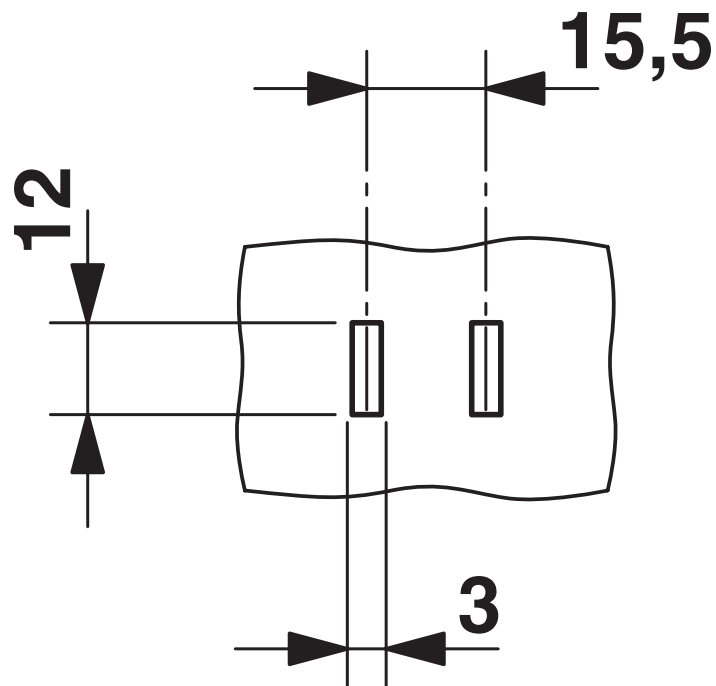

Punching template

Dimensional drawing

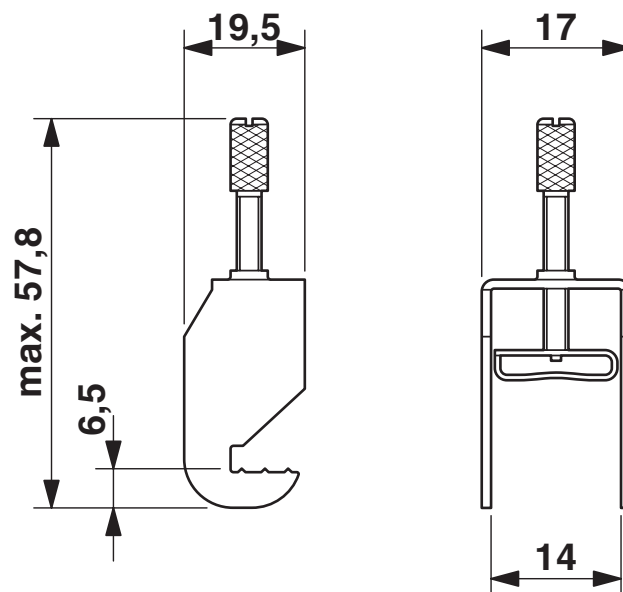

SK 14-D - Shield connection clamp

3026874

<https://www.phoenixcontact.com/au/products/3026874>



Dimensional drawing

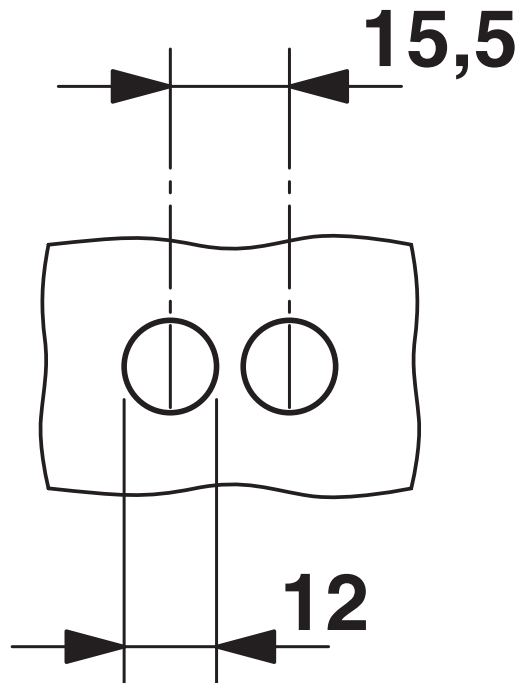

Drilling diagram

SK 14-D - Shield connection clamp



3026874

<https://www.phoenixcontact.com/au/products/3026874>

Classifications

ECLASS

ECLASS-11.0	27141150
ECLASS-12.0	27141150
ECLASS-13.0	27250309

ETIM

ETIM 9.0	EC002020
----------	----------

UNSPSC

UNSPSC 21.0	39121400
-------------	----------

SK 14-D - Shield connection clamp



3026874

<https://www.phoenixcontact.com/au/products/3026874>

Environmental product compliance

China RoHS	Environmentally friendly use period: unlimited = EFUP-e No hazardous substances above threshold values
------------	---

Phoenix Contact 2024 © - all rights reserved
<https://www.phoenixcontact.com>

PHOENIX CONTACT PTY Ltd
Unit 7, 2-8 South Street
Rydalmere NSW 2116
1300 786 411
customerservice@phoenixcontact.com.au