

Simple, Compact Inverters

# SYSDRIVE JX Series

## Easy-to-Use Compact Simplified Inverter for the Customer's Environment and Application Demands

- Provides a wide ranging capacity from 0.2 to 3.7 kW in spite of the compact size
- The main circuit adopts upper/lower wiring as with a conductor
- Side-by-side mounting Contributes to space saving
- The PID function is featured for the easier control of the fan and pump
- The three-phase models incorporate a zero-phase reactor (radio noise filter) as a standard specification
- ModBus-RTU communication allows you to perform network operation at low cost.



## Model Number Explanation

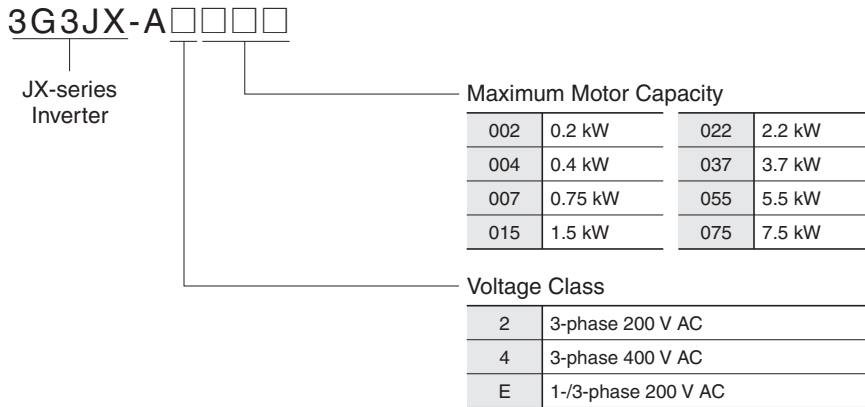

## Standard Models

Rated voltage	Enclosure rating	Max. applicable motor capacity	Model
3-phase 200 V AC	IP20	0.2 kW	3G3JX-A2002
		0.4 kW	3G3JX-A2004
		0.75 kW	3G3JX-A2007
		1.5 kW	3G3JX-A2015
		2.2 kW	3G3JX-A2022
		3.7 kW	3G3JX-A2037
		5.5 kW	3G3JX-A2055
7.5 kW		3G3JX-A2075	
1-/3-phase 200 V AC		0.2 kW	3G3JX-AE002
		0.4 kW	3G3JX-AE004
		0.75 kW	3G3JX-AE007
		1.5 kW	3G3JX-AE015
		2.2 kW	3G3JX-AE022
3-phase 400 V AC		0.4 kW	3G3JX-A4004
	0.75 kW	3G3JX-A4007	
	1.5 kW	3G3JX-A4015	
	2.2 kW	3G3JX-A4022	
	3.7 kW	3G3JX-A4037	
	5.5 kW	3G3JX-A4055	
	7.5 kW	3G3JX-A4075	

### International Standards (EC Directives and UL/cUL Standards)

The 3G3JX Inverter meets the EC Directives and UL/cUL standard requirements for worldwide use.

Classification		Applicable standard
EC Directives	EMC Directive	EN61800-3: 2004
	Low-voltage Directive	EN61800-5-1: 2003
UL/cUL Standards		UL508C

# Standard Specification List

## 200-V Class

Item Model name (3G3JX-)		3-phase 200-V class							
		A2002	A2004	A2007	A2015	A2022	A2037	A2055	A2075
Applicable motor capacity *1	kW	0.2	0.4	0.75	1.5	2.2	3.7	5.5	7.5
	HP	1/4	1/2	1	2	3	5	7.5	10
Rated output capacity (kVA)	200 V	0.4	0.9	1.3	2.4	3.4	5.5	8.3	11.0
	240 V	0.5	1.0	1.6	2.9	4.1	6.6	9.9	13.3
Rated input voltage		3-phase (3-wire) 200 V -15% to 240 V +10%, 50/60 Hz ±5%							
Built-in filter		Radio noise filter							
Rated input current (A)		1.8	3.4	5.2	9.3	13.0	20.0	30.0	40.0
Rated output voltage *2		3-phase: 200 to 240 V (according to the input voltage)							
Rated output current (A)		1.4	2.6	4.0	7.1	10.0	15.9	24.0	32.0
Weight (kg)		0.8	0.9	1.1	2.2	2.4	2.4	4.2	4.2
Cooling method		Self-cooling			Forced-air-cooling				
Braking torque	At short-time deceleration *3 At capacitor feedback	Approx. 50%				Approx. 20% to 40%		Approx. 20%	
	DC injection braking	Injection braking frequency/time, braking force variable, frequency control available							

## 400-V Class

Item Model name (3G3JX-)		3-phase 400-V class						
		A4004	A4007	A4015	A4022	A4037	A4055	A4075
Applicable motor capacity *1	kW	0.4	0.75	1.5	2.2	3.7	5.5	7.5
	HP	1/2	1	2	3	5	7.5	10
Rated output capacity (kVA)	380 V	0.9	1.6	2.5	3.6	5.6	8.5	10.5
	480 V	1.2	2.0	3.1	4.5	7.1	10.8	13.3
Rated input voltage		3-phase (3-wire) 380 V -15% to 480 V +10%, 50/60 Hz ±5%						
Built-in filter		Radio noise filter						
Rated input current (A)		2.0	3.3	5.0	7.0	11.0	16.5	20.0
Rated output voltage *2		3-phase: 380 to 480 V (according to the input voltage)						
Rated output current (A)		1.5	2.5	3.8	5.5	8.6	13.0	16.0
Weight (kg)		1.5	2.3	2.4	2.4	2.4	4.2	4.2
Cooling method		Self-cooling		Forced-air-cooling				
Braking torque	At short-time deceleration *3 At capacitor feedback	Approx. 50%			Approx. 20% to 40%		Approx. 20%	
	DC injection braking	Injection braking frequency/time, braking force variable, frequency control available						

## 1/3-phase 200-V Class

Item Model name (3G3JX-)		1/3-phase 200-V Class				
		AE002	AE004	AE007	AE015	AE022
Applicable motor capacity *1	kW	0.2	0.4	0.75	1.5	2.2
	HP	1/4	1/2	1	2	3
Rated output capacity (kVA)	200 V	0.4	0.9	1.3	2.4	3.4
	240 V	0.5	1.0	1.6	2.9	4.1
Rated input voltage		1/3-phase 200 V -15% to 240 V +10%, 50/60 Hz ±5%				
Built-in filter		None				
Rated input current (A)		1.8	3.4	5.2	9.3	13.0
Rated output voltage *2		3-phase: 200 to 240 V (according to the input voltage)				
Rated output current (A)		1.4	2.6	4.0	7.1	10.0
Weight (kg)		0.8	0.9	1.5	2.3	2.4
Cooling method		Self-cooling			Forced-air-cooling	
Braking torque	At short-time deceleration *3 At capacitor feedback	Approx. 50%			Approx. 20% to 40%	
	DC injection braking	Injection braking frequency/time, braking force variable, frequency control available				

**Common Specifications**

Item		Specifications
<b>Enclosure rating *4</b>		Semi-closed (IP20)
<b>Control</b>	<b>Control method</b>	Phase-to-phase sinusoidal modulation PWM
	<b>Output frequency range *5</b>	0.5 to 400 Hz
	<b>Frequency precision *6</b>	Digital command: $\pm 0.01\%$ of the max. frequency Analog command: $\pm 0.4\%$ of the max. frequency (25°C $\pm 10^\circ\text{C}$ )
	<b>Frequency setting resolution</b>	Digital setting: 0.1 Hz Analog setting: Max. frequency/1000
	<b>Voltage/Frequency characteristics</b>	V/f characteristics (constant/reduced torque)
	<b>Overload current rating</b>	150% for 1 min
	<b>Acceleration/Deceleration time</b>	0.01 to 3000 s (line/curve selection), 2nd acceleration/deceleration setting available
	<b>Carrier frequency modification range</b>	2 to 12 kHz
	<b>DC injection braking</b>	Starts at a frequency lower than that in deceleration via the STOP command, at a value set lower than that during operation, or via an external input. (Level and time settable.)
<b>Protective functions</b>		Overcurrent, overvoltage, undervoltage, electronic thermal, temperature error, ground-fault overcurrent at power-on state, overload limit, incoming overvoltage, external trip, memory error, CPU error, USP trip, communication error, overvoltage protection during deceleration, momentary power interruption protection, emergency shutoff
<b>Input signal</b>	<b>Multi-function input</b>	FW (forward), RV (reverse), CF1 to CF4 (multi-step speed), JG (jogging), DB (external DC injection braking), SET (2nd function), 2CH (2-step acceleration/deceleration), FRS (free run), EXT (external trip), USP (USP function), SFT (soft lock), AT (analog current input function selection), RS (reset), PTC (thermistor input), STA (3-wire startup), STP (3-wire stop), F/R (3-wire forward/reverse), PID (PID selection), PIDC (PID integral reset), UP (UP of UP/DWN function), DWN (DWN of UP/DWN function), UDC (data clear of UP/DWN function), OPE (forced OPE mode), ADD (frequency addition), F-TM (forced terminal block), RDY (operation ready), SP-SET (special setting), EMR (emergency shutoff)
<b>Output signal</b>	<b>Multi-function output</b>	RUN (signal during operation), FA1 (frequency arrival signal 1), FA2 (frequency arrival signal 2), OL (overload warning signal), OD (PID excess deviation signal), AL (alarm signal), DC (analog input disconnection detection signal), FBV (PID FB status output), NDC (network error), LOG (logical operation result), ODC (communication option disconnected), LOC (light load signal)
	<b>Frequency monitor</b>	Analog output (0 to 10 V DC, 1 mA max.) Frequency/Current signals are selectable via the AM output terminal.
	<b>Relay output</b>	The relay (SPDT contact) outputs signals corresponding to the multi-function output.
<b>Other functions</b>		AVR function, V/f characteristic selection, upper/lower limit, 16-step speeds, starting frequency adjustment, jogging operation, carrier frequency adjustment, PID control, frequency jump, analog gain/bias adjustment, S-shape acceleration/deceleration, electronic thermal characteristics/level adjustment, retry function, simplified torque boost, trip monitor, soft lock function, frequency conversion display, USP function, 2nd control function, motor rotation speed UP/DOWN, overcurrent suppression function
<b>General specifications</b>	<b>Ambient temperature</b>	-10°C to 50°C (Both the carrier frequency and output current need to be reduced at over 40°C.)
	<b>Ambient storage temperature</b>	-20°C to 65°C (short-time temperature during transport)
	<b>Humidity</b>	20% to 90% RH
	<b>Vibration</b>	5.9 m/s <sup>2</sup> (0.6G), 10 to 55 Hz (Complies with the test method specified in JIS C0040 (1999).)
	<b>Location</b>	At a maximum altitude of 1,000 m; indoors (without corrosive gases or dust)
	<b>Applicable standard</b>	Complies with UL, cUL, CE standards. (Insulation distance)
<b>Options</b>		Noise filter, AC/DC reactors, regenerative braking unit and resistor, etc.

- \*1. The applicable motor is a 3-phase standard motor. For using any other type, be sure that the rated current does not exceed that of the Inverter.
- \*2. Output voltage decreases according to the level of the power supply voltage.
- \*3. The braking torque at the time of capacitor feedback is an average deceleration torque at the shortest deceleration (when it stops from 50 Hz), not a continuous regeneration torque. Also, the average deceleration torque varies depending on the motor loss. The value is reduced in operation over 50 Hz. Note that no regenerative braking circuit is built into the Inverter. If you need a larger regenerative torque, use the optionally available regenerative braking unit and resistor.  
The regenerative braking unit should be used only for short-time regeneration.
- \*4. Protection method complies with JEM 1030.
- \*5. To operate the motor at over 50/60 Hz, contact the motor manufacturer to find out the maximum allowable speed of revolution.
- \*6. For the stable control of the motor, the output frequency may exceed the maximum frequency set in A004 (A204) by 2 Hz max.

## Terminal Block Specifications

### Terminal Block Position

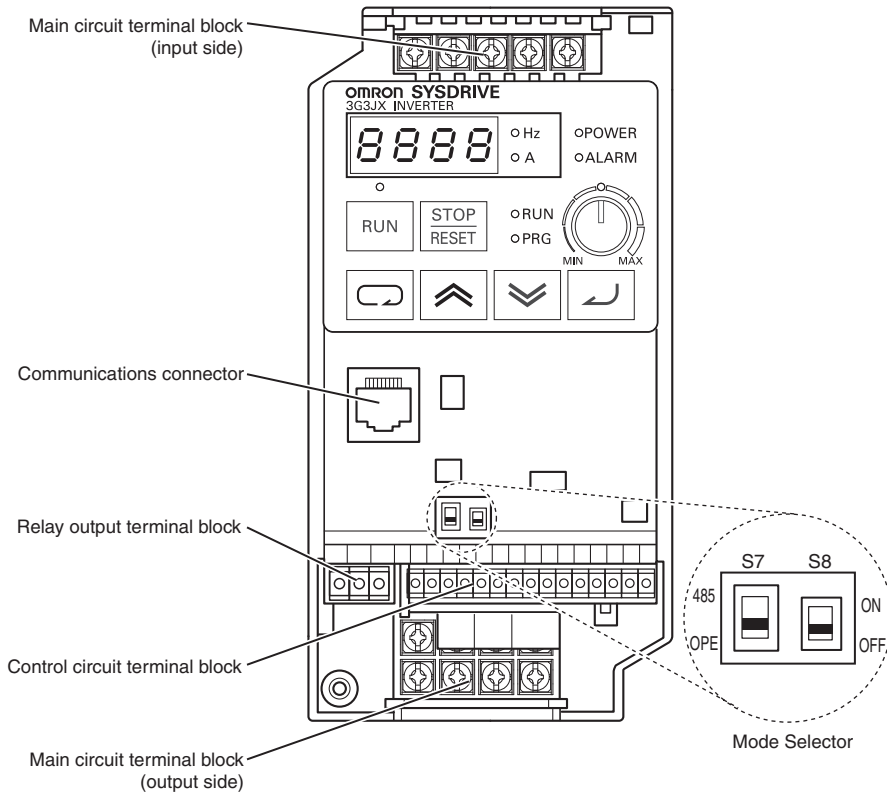

**Note:** This illustration shows the terminal block with the front cover removed.

### Specifications of Main Circuit Terminals

Upper side of the body



\* 3G3JX-AE□□□ terminal symbols



Lower side of the body

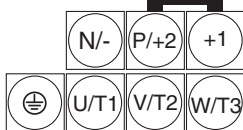

Terminal symbol	Terminal name	Function	Connection example
R/L1 (L1) *, S/L2 (L2) *, T/L3 (N/L3) *	Main power supply input terminal	Connect the input power supply.	<p>Power supply</p> <p>Motor</p> <p>ELB</p>
U/T1, V/T2, W/T3	Inverter output terminal	Connect to the motor.	
+1, P/+2	External DC reactor terminal	Normally connected by the short-circuit bar. Remove the short-circuit bar between +1 and P/+2 when a DC reactor is connected.	
P/+2, N/-	Regenerative braking unit connection terminal	Connect optional regenerative braking units. (If a braking torque is required)	
⊕	Ground terminal	Ground (Connect to ground to prevent electric shock and reduce noise.)	

\* 3G3JX-AE□□□ terminal symbols are shown in brackets.

**Control Circuit Terminals Specifications**

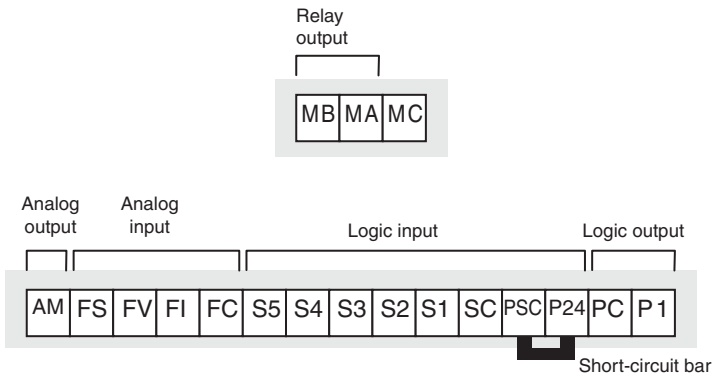

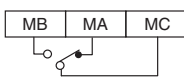
	Terminal symbol	Terminal name and function	Default setting	Note		
Input signal	PSC	External power supply terminal for input signal (input) ...At sink logic	-	24 V DC ±10% 30 mA max.		
		Internal power supply output terminal for input signal (output) ...At source logic	-	24 V DC ±10% 100 mA max.		
	S1	Multi-function input terminals S1 to S5 Select 5 functions among the 31 functions and allocate them to terminals S1 to S5. The terminal allocation is changed automatically when the emergency shutoff function is used.	Forward/Stop	Contact input Close: ON (Start) Open: OFF (Stop) Minimum ON time: 12 ms min.		
	S2		Reverse/Stop			
	S3		Fault reset			
	S4		Emergency stop fault			
S5	Multi-step speed reference 1	-	-			
SC	Input signal common	-	-			
Monitor signal	AM	Analog frequency monitor/Analog output current monitor	Analog frequency monitor	-		
Frequency reference input	FS	Frequency reference power supply	-	10 V DC 10 mA max.		
	FV	Voltage frequency reference signal	-	0 to 10 V DC Input impedance 10 kΩ When installing variable resistors at FS, FV, and FC (1 to 2 kΩ)		
	FI	Current frequency reference signal	-	4 to 20 mA DC Input impedance 250 Ω		
	FC	Frequency reference common	-	-		
Output signal	P1	Multi-function output terminal Select the status of the Inverter and allocate it to terminal P1.	Frequency arrival signal at a constant speed	27 V DC 50 mA max.		
	PC	Output signal common	-			
Relay output signal	MA	 <p>Factory default relay settings Under normal operation: MA-MC Closed Under abnormal operation or power shutdown: MA-MC Open</p>	Output terminal	Contact capacity	Resistance load	Inductive load
	MB		MA-MC	Max.	AC250V 2.5A DC30V 3A	AC250V 0.2A DC30V 0.7A
				Min.	AC100V 10mA DC5V 100mA	
MC	MB-MC	Max.	AC250V 1A DC30V 1A	AC250V 0.2A DC30V 0.2A		
		Min.	AC100V 10mA DC5V 100mA			

## Mode Selector

### RS-485 Communication/Operator Selector (S7)

Select the mode according to the option connected to the communications connector.

When using the 3G3AX-OP01 supplied with the Inverter, it is available regardless of the switch condition

Symbol	Name	Status	Description
S7	RS-485 communication/operator selector	485	RS485 Modbus communication
		OPE [Default]	Digital Operator (Option: 3G3AX-OP1)

### Emergency shutoff selector (S8)

Use this selector to enable the emergency shutoff input function.

Symbol	Name	Status	Description
S8	Emergency shutoff selector	ON	Emergency shutoff input enabled *
		OFF [Default]	Normal

\* The multi-function input terminal 3 is switched to a terminal for emergency shutoff input, and the allocation of other multi-function input terminals is also changed automatically. Do not set to ON immoderately. For details, refer to "Emergency Shutoff Input Function".

Standard Connection Diagram

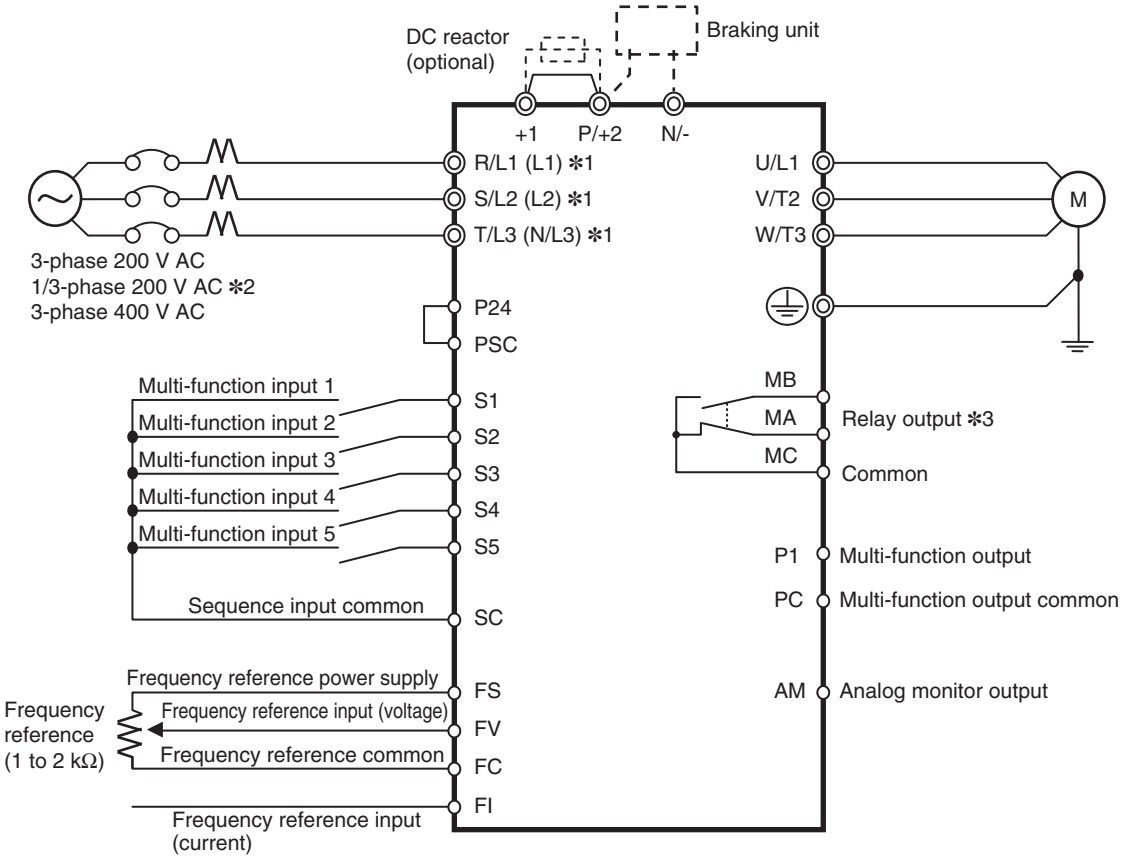

\*1. The 3G3JX-AE□□□ terminal symbols are shown in brackets.  
 \*2. Connect a single-phase 200-V AC input to terminals L1 and N/L3.  
 \*3. By factory default, MA is set to MC contact, and MB to NO contact in the relay output (MA, MB) selection (C036).

# Nomenclature and Functions

## Inverter Nomenclature and Functions

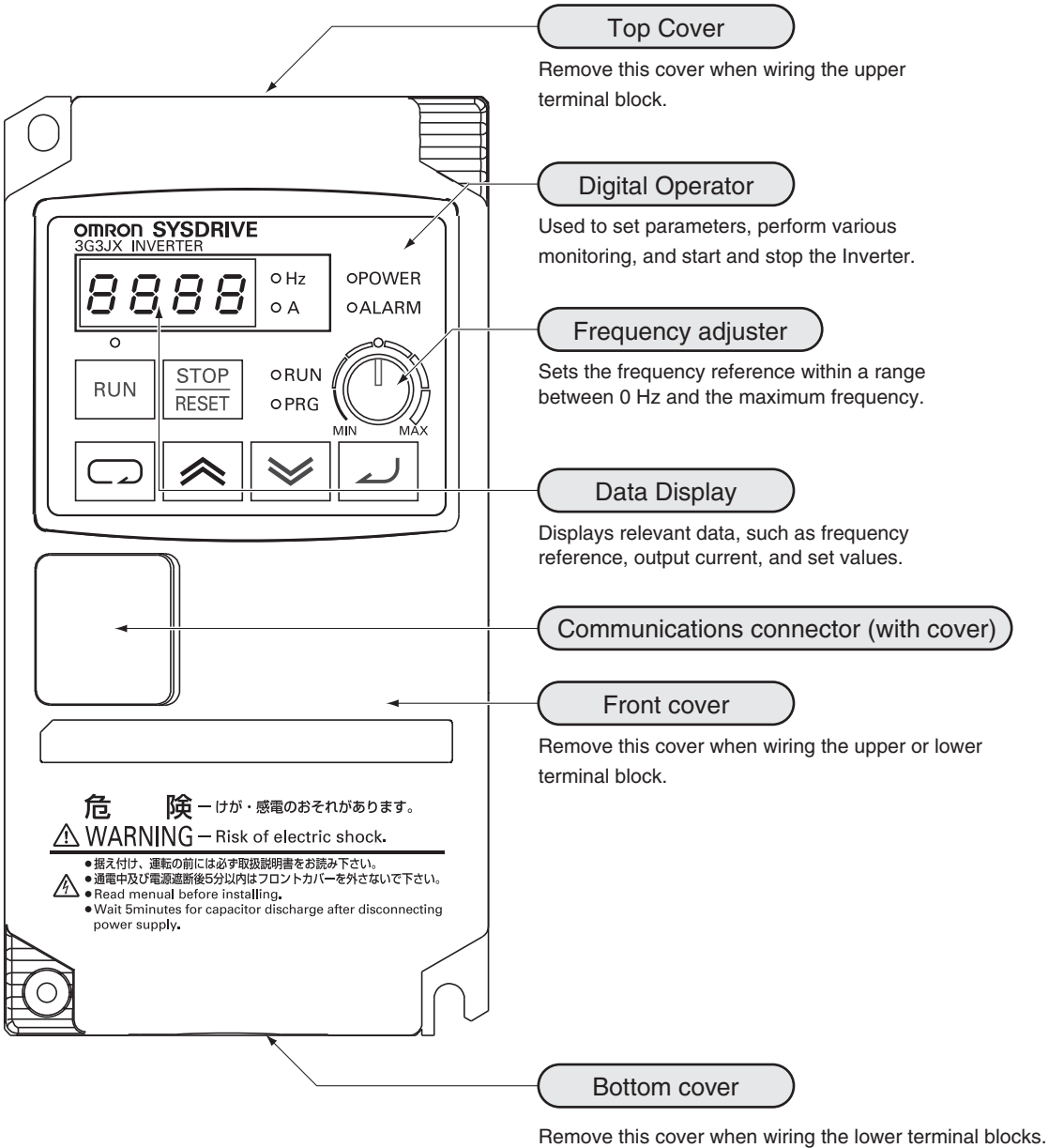

- Note:**
1. Connect the communications cable after opening the cover of the communications connector. Remove the front cover to switch communications.
  2. The cover of the communications connector is removable. Remove the front cover to attach it.

**Part Names and Descriptions of the Digital Operator**

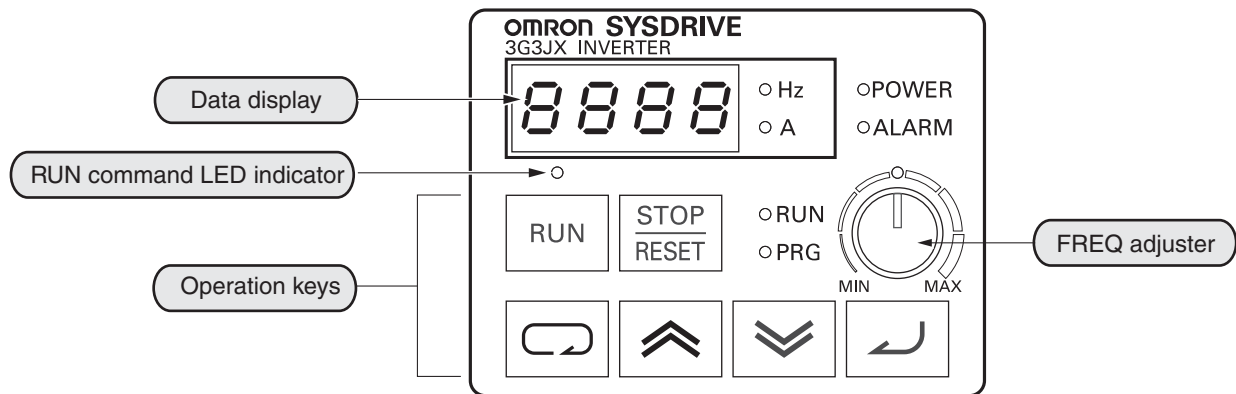

	Name	Description
○POWER	POWER LED indicator	Lit when the power is supplied to the control circuit.
○ALARM	ALARM LED indicator	Lit when an Inverter error occurs.
○RUN	RUN (during RUN) LED indicator	Lit when the Inverter is running.
○PRG	PROGRAM LED indicator	Lit when the set value of each function is indicated on the data display. Blinks during warning (when the set value is incorrect).
	Data display	Displays relevant data, such as frequency reference, output current, and set values.
○ Hz ○ A	Data display LED indicator	Lit according to the indication on the data display. Hz: Frequency A: Current
	Volume LED indicator	Lit when the frequency reference source is set to the FREQ adjuster.
	FREQ adjuster	Sets a frequency. Available only when the frequency reference source is set to the FREQ adjuster. (Check that the Volume LED indicator is lit.)
○	RUN command LED indicator	Lit when the RUN command is set to the Digital Operator. (The RUN key on the Digital Operator is available for operation.)
	RUN key	Activates the Inverter. Available only when operation via the Digital Operator is selected. (Check that the RUN command LED indicator is lit.)
	STOP/RESET key	Decelerates and stops the Inverter. Functions as a reset key if an Inverter error occurs.
	Mode key	Switches between the monitor mode (d□□□), the basic function mode (F□□□), and the extended function mode (A□□□, b□□□, c□□□, H□□□).
	Enter key	Enters the set value. (To change the set value, be sure to press the Enter key.)
	Increment key	Changes the mode. Also, increases the set value of each function.
	Decrement key	Changes the mode. Also, decreases the set value of each function.

**Dimensions**

- 3G3JX-A2002
- 3G3JX-A2004
- 3G3JX-A2007
- 3G3JX-AE002
- 3G3JX-AE004

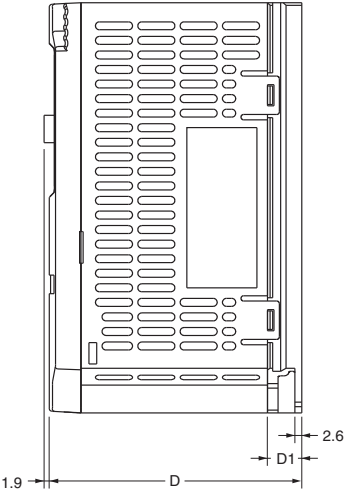
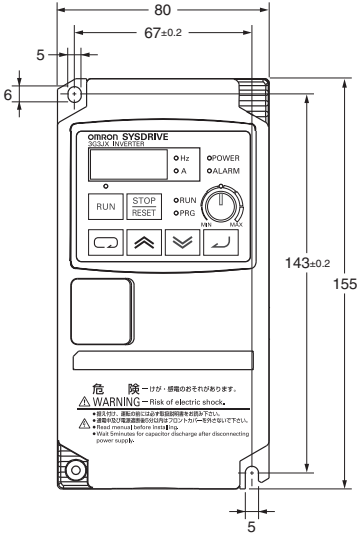

Rated voltage	Model 3G3JX-	Dimensions (mm)	
		D	D1
3phase 200 V AC	A2002	95.5	13
	A2004	109.5	27
	A2007	132.5	50
1/3phase 200 V AC	AE002	95.5	13
	AE004	109.5	27

- 3G3JX-A4004
- 3G3JX-AE007

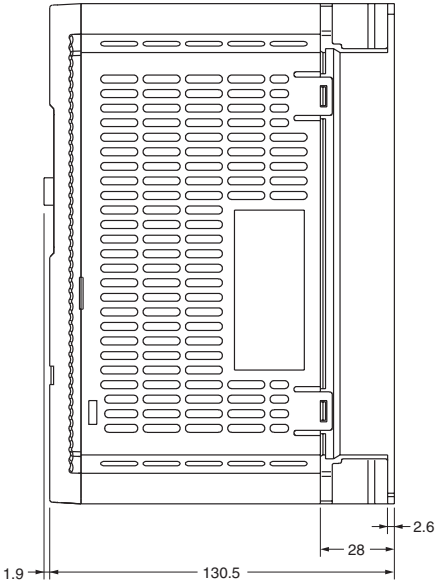
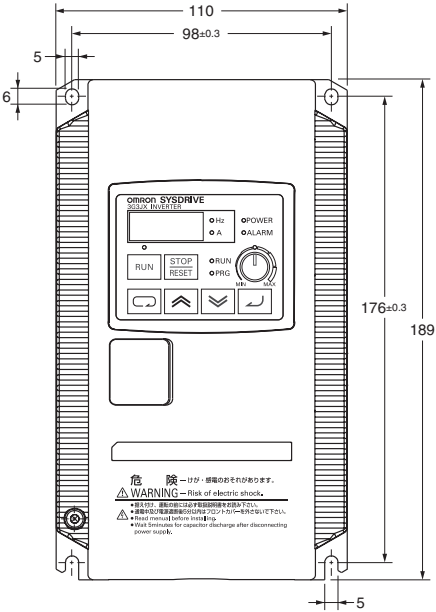

3G3JX-A2015  
 3G3JX-A2022  
 3G3JX-A2037  
 3G3JX-A4007  
 3G3JX-A4015  
 3G3JX-A4022  
 3G3JX-A4037  
 3G3JX-AE015  
 3G3JX-AE022

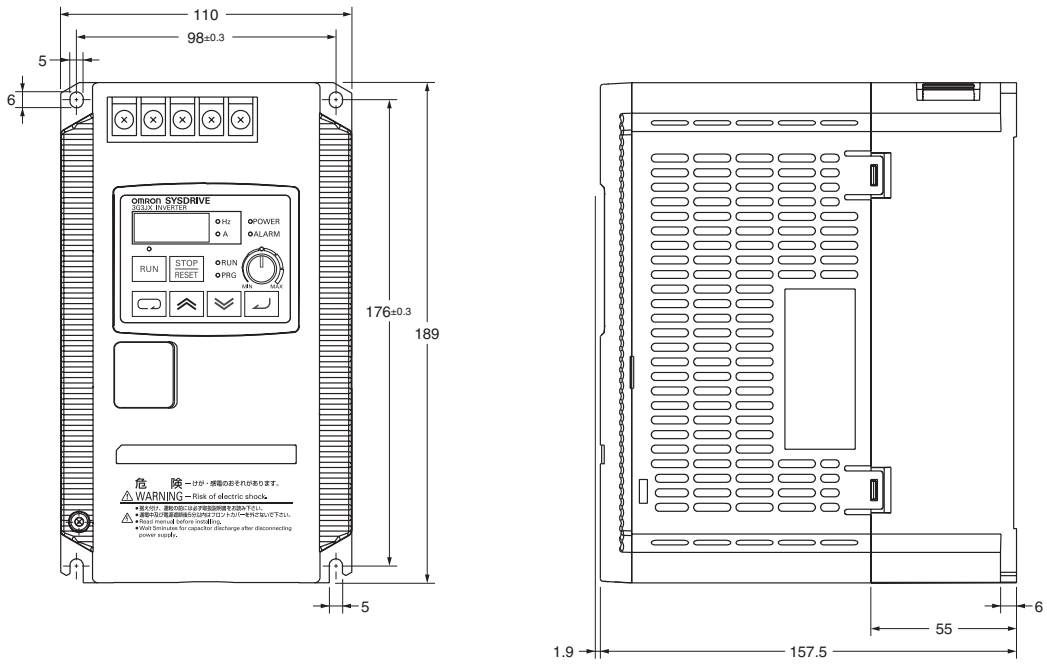

3G3JX-A2055  
 3G3JX-A2075  
 3G3JX-A4055  
 3G3JX-A4075

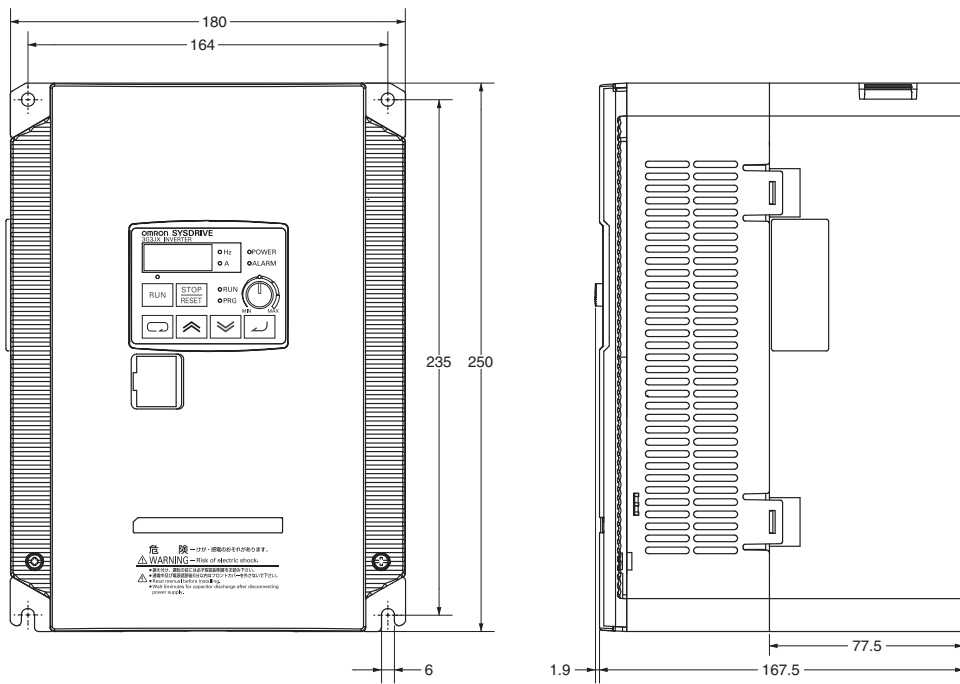

# SYSDRIVE JX Series

## Using Digital Operator

### 1. Setting the maximum output frequency

Power ON

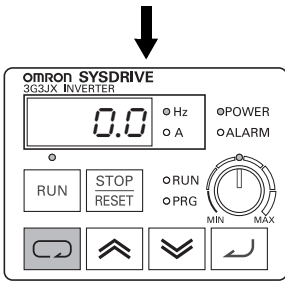

(1) 0.0 or the value previously monitored is displayed.

Press key.

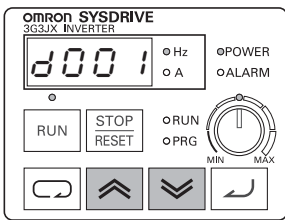

(2) Function code appears.

Press until A --- appears.

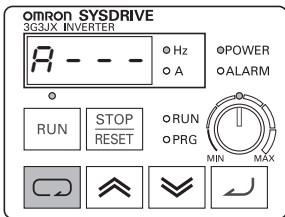

(3) A --- appears.

Press key.

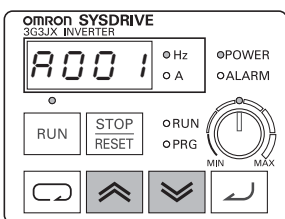

(4) A001 or the code number set in the end of last setting is displayed.

Press until A --- appears.

(It continues in upper right.)

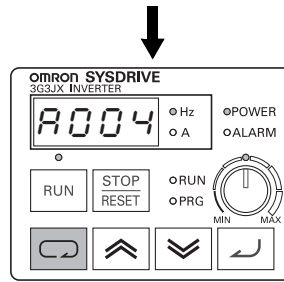

(5) A004 appears.

Press key.

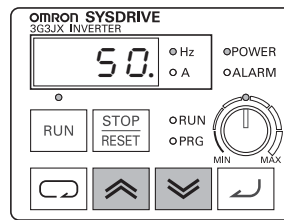

(6) Preset value is displayed.

Press to set desired value.

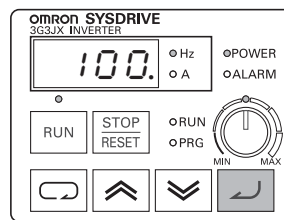

(7) Newly set value is displayed.

Press key to store the value.

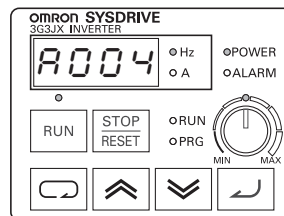

(8) Returns to A004 and the setting is complete.

- To run the motor, go back to monitor mode or basic setting mode.
- Pressing key for a while and back to d001.

## 2. Running the motor (by potentiometer)

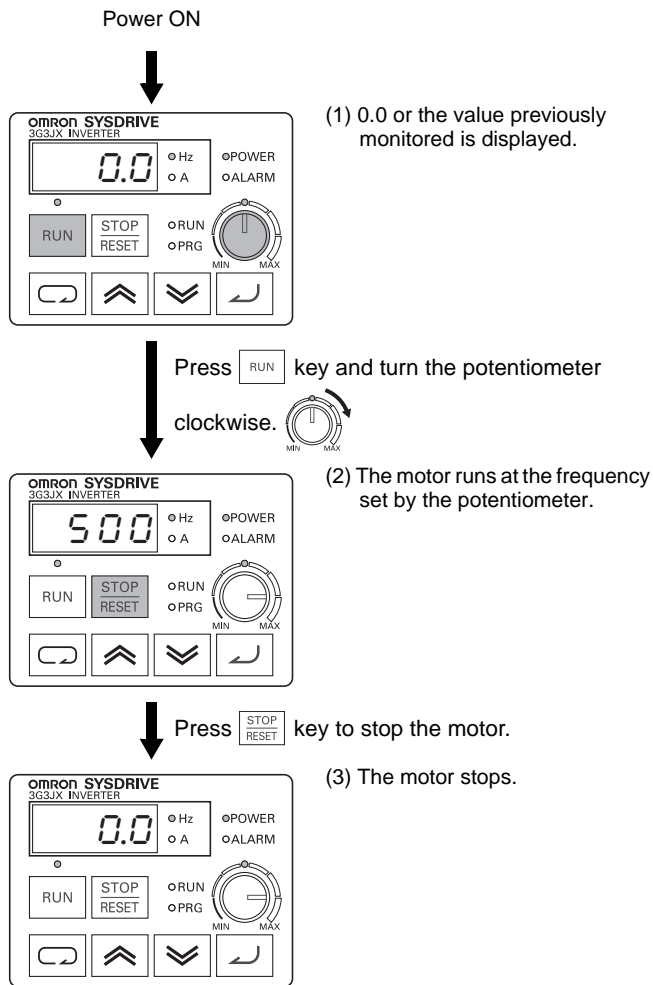

## 3. Monitoring output current value

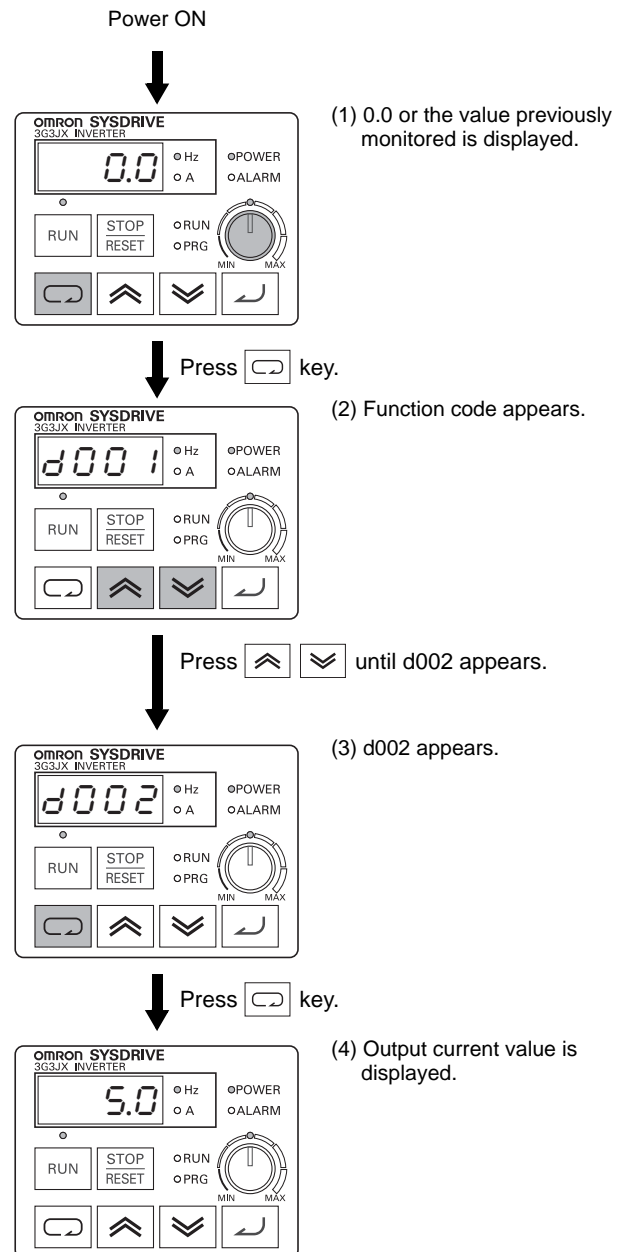

## Protective and Diagnostic Functions

### Error Code List

Display on Digital Operator	Name	Description
E_01	Overcurrent trip	Constant speed
E_02		Deceleration
E_03		Acceleration
E_04		Others
If the motor is restrained, or rapidly accelerated or decelerated, a large current will flow through the Inverter, which will result in breakage. To avoid this, an overcurrent protection circuit works to shut off the Inverter output.		
E_05	Overload trip	If an Inverter output current is detected and the motor is overloaded, an electronic thermal inside the Inverter operates to shut off the Inverter output. After a trip occurs, normal operation is restored in 10 seconds by resetting the Inverter.
E_07	Overvoltage trip	If the incoming voltage and regenerative energy from the motor are too high, a protection circuit works to shut off the Inverter output when the voltage on the converter exceeds the specified level.
E_08	EEPROM error	Shuts off the output if an error occurs in the EEPROM built into the Inverter due to external noise and abnormal temperature rise. Check the set data again if the [E_08] error occurs. If the power is shut off during data initialization, an EEPROM error [E_08] may occur when the power is next turned on. Shut off the power after completing data initialization.
E_09	Undervoltage trip	Shuts off the output if the incoming voltage drops below the specified level, causing the control circuit not to work properly during a momentary power interruption.
E_11	CPU error	Shuts off the output if the internal CPU has malfunctioned. If the multi-function output terminal (relay terminal) is set to 05 (alarm), the signal may not be output during the CPU error [E_11]. In this case, no data is stored in the trip monitor. The same thing could happen if AL (05) is allocated to the relay output terminal. Again, no data is stored.
E_12	External trip	If an error occurs in the external equipment or devices, the Inverter receives the signal, and the output is shut off. (Available with the external trip function selected)
E_13	USP trip	Appears if the Inverter is turned on with the RUN command being input. (Available with the USP function selected) If an undervoltage trip [E_09] occurs with the USP terminal set to ON, the trip, after released by resetting, becomes a USP trip [E_13]. Reset again to release the trip.
E_14	Ground fault trip	Shuts off the output if a ground fault between the Inverter output unit and the motor is detected when turning on the power. The ground fault trip [E_14] cannot be released with the reset input. Shut off the power and check the wiring.
E_15	Incoming overvoltage trip	Appears if the incoming voltage has remained high for 100 seconds while the Inverter output is stopped.
E_21	Temperature error	Shuts off the output if the temperature has risen in the main circuit due to malfunction of the cooling fan or other reason.
E_30	Driver error	Shuts off the output if overcurrent is detected in the main circuit.
E_35	Thermistor error	While the thermistor input function is used, this detects the resistance of the external thermistor and shuts off the Inverter output.
E_37	Emergency shutoff	With the emergency shutoff selected (DIP switch on the control board SW8 = ON), this error appears when an emergency shutoff signal is input from input terminal 3.
E_60	Communications error	Occurs when the communication watchdog timer times out.

## 3G3JX Related Option

The following optional items and peripheral devices can be used with the Inverter. Select them according to the application.

Type	Specifications						Description
	Type	Voltage	Inverter 3G3JX-□	Rated Current (A)	Leakage Norm/Max	kg	
EMC Line Filters	Foot Mounting [Rasmi]	200V (Single- phase)	AE002 / AE004	6	0.7mA	0.5	AX-FIJ1006-RE
			AE007	10	0.7mA	0.6	AX-FIJ1010-RE
			AE015 / AE022	23	0.7mA	0.8	AX-FIJ1023-RE
		200V (Three- phase)	A2002 / A2004 / A2007	6	0.3 / 16mA	1.0	AX-FIJ2006-RE
			A2015 / A2022 / A2037	20	1.0 / 50mA	1.3	AX-FIJ2020-RE
			A2055 / A2075	40	1.3 / 65mA	2.3	AX-FIJ2040-RE
		400V (Three- phase)	A4004 / A4007 / A4015	5	0.6 / 70mA	0.9	AX-FIJ3005-RE
			A4022 / A4037	11	0.6 / 70mA	1.1	AX-FIJ3011-RE
			A4055 / A4075	20	0.3 / 40mA	1.7	AX-FIJ3020-RE

Type	Specifications		Description	
	Voltage	Inverter 3G3JX-□		
Input AC Reactors	200V (Single-phase)	AE002 / AE004 / AE007 / AE015 / AE022	UNDER DEVELOPMENT	
	200V (Three-phase)	A2002 / A2004 / A2007	AX-RAI02800080-DE	
		A2015 / A2022 / A2037	AX-RAI00880175-DE	
		A2055 / A2075	AX-RAI00350335-DE	
	400V (Three-phase)	A4004 / A4007 / A4015	AX-RAI07700042-DE	
		A4022 / A4037	AX-RAI03500090-DE	
		A4055 / A4075	AX-RAI01300170-DE	
	DC Reactors	200V (Single-phase)	AE002	AX-RC10700032-DE
			AE004	AX-RC06750061-DE
AE007			AX-RC03510093-DE	
AE015			AX-RC02510138-DE	
AE022			AX-RC01600223-DE	
200V (Three-phase)		A2002	AX-RC21400016-DE	
		A2004	AX-RC10700032-DE	
		A2007	AX-RC06750061-DE	
		A2015	AX-RC03510093-DE	
		A2022	AX-RC02510138-DE	
		A2037	AX-RC01600223-DE	
		A2055	AX-RC01110309-DE	
A2075		AX-RC00840437-DE		
400V (Three-phase)		A4004	AX-RC43000020-DE	
		A4007	AX-RC27000030-DE	
		A4015	AX-RC14000047-DE	
		A4022	AX-RC10100069-DE	
		A4037	AX-RC06400116-DE	
	A4055	AX-RC04410167-DE		
A4075	AX-RC03350219-DE			

# SYSDRIVE JX Series

Types	Specifications		Model
	Voltage	Inverter 3G3JX-□	
Output AC Reactors	200V (Single-phase)	AE002 / AE004	AX-RAO11500026-DE
		AE007	AX-RAO07600042-DE
		AE015	AX-RAO04100075-DE
		AE022	AX-RAO03000105-DE
	200V (Three-phase)	A2002 / A2004	AX-RAO11500026-DE
		A2007	AX-RAO07600042-DE
		A2015	AX-RAO04100075-DE
		A2022	AX-RAO03000105-DE
		A2037	AX-RAO01830160-DE
		A2055	AX-RAO01150220-DE
		A2075	AX-RAO00950320-DE
	400V (Three-phase)	A4004 / A4007 / A4015	AX-RAO16300038-DE
		A4022	AX-RAO11800053-DE
		A4037	AX-RAO07300080-DE
		A4055	AX-RAO04600110-DE
		A4075	AX-RAO03600160-DE

Types	Specifications		Model
	Description	Diameter	
Radio Noise Filters	For 2.2 kW motors or below	21	AX-FER2102-RE
	For 15 kW motors or below	25	AX-FER2515-RE

Types	Description	Model
PC Cable	RJ45 to USB Converter, 2m Cable	3G3AX-PCACN2
Remote Operator	LCD Remote operator *1 (5 Line LCD remote operator with copy function, cable length max. 3m.)	AX-OP05-E
	LED Remote Operator with frequency reference volume	3G3AX-OP01
	3 meters cable for connecting remote operator	3G3AX-CAJOP300-EE
	Mounting Kit for LED Operator	4X-KITMINI
Others	RJ45 T-Branch Cable	3G3AX-CTB020-EE
	RJ45 T-Branch Terminator Resistor	3G3AX-CTR150-EE

\*1 Please note, for 3G3JX models, the operator will only display 2 lines of text.

# Overview of Inverter Selection

## Selecting the Motor Capacity

Select a motor before selecting the Inverter. Calculate the load inertia in the application, calculate the motor capacity and torque required to handle the load, and select an appropriate motor.

### Simple Selection Method (Calculation of the Required Output)

With this method, you select the motor based on the output (W) required when the motor is rotating at a steady rate. This method does not include the involved calculations for acceleration and deceleration, so add some extra capacity to the calculated value when selecting the motor. This is a simple way to calculate the size of motor needed in equipment that operates at a steady rate for long periods, such as fans, conveyors, and mixing machines. This method is not suitable for the following kinds of applications:

- Applications requiring sudden start-ups
- Applications where the equipment starts and stops frequently
- Applications where there is a lot of inertia in the transmission system
- Applications with a very inefficient transmission system

### Linear Motion: Steady Power P<sub>0</sub> (kW)

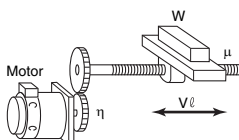

$$P_0 = \frac{m \cdot W \cdot V \ell}{6120 \cdot \eta}$$

$\mu$ : Friction coefficient  
 $W$ : Weight of moveable load (kg)  
 $V \ell$ : Speed of moveable load (m/min)  
 $\eta$ : Efficiency of reduction mechanism (transmission)

### Rotational Motion: Steady Power P<sub>0</sub> (kW)

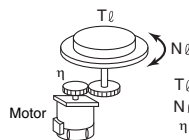

$$P_0 = \frac{T_l \cdot N_l}{9535 \cdot \eta}$$

$T_l$ : Load torque at load axis (N·m)  
 $N_l$ : Speed of load axis (r/min)  
 $\eta$ : Efficiency of reduction mechanism (transmission)

### Detailed Selection Method (R.M.S. Calculation Method)

With this method, you calculate the effective torque and maximum torque required in the application's operating pattern. This method provides a detailed motor selection that matches the operating pattern.

### Calculating the Motor Shaft Conversion Inertia

Use the following equations to calculate the inertia of all of the parts and convert that to the motor shaft conversion inertia.

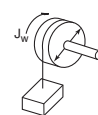

$$J_w = J_1 + J_2 = \left( \frac{M_1 \cdot D_1^2}{8} + \frac{M_2 \cdot D_2^2}{4} \right) \times 10^{-6} \text{ (kg}\cdot\text{m}^2\text{)}$$

$J_w$ : Inertia (kg·m<sup>2</sup>)  
 $J_1$ : Inertia of cylinder (kg·m<sup>2</sup>)  
 $J_2$ : Inertia due to object (kg·m<sup>2</sup>)  
 $D$ : Diameter (mm)  
 $M_1$ : Mass of cylinder (kg)  
 $M_2$ : Mass of object (kg)

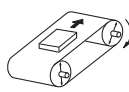

$$J_w = J_1 + J_2 + J_3 + J_4 = \left( \frac{M_1 \cdot D_1^2}{8} + \frac{M_2 \cdot D_2^2}{8} + \frac{D_3^2}{D_2^2} + \frac{M_3 \cdot D_1^2}{4} + \frac{M_4 \cdot D_1^2}{4} \right) \times 10^{-6} \text{ (kg}\cdot\text{m}^2\text{)}$$

$J_w$ : Inertia (kg·m<sup>2</sup>)  
 $J_1$ : Inertia of cylinder 1 (kg·m<sup>2</sup>)  
 $J_2$ : Inertia of cylinder 2 (kg·m<sup>2</sup>)  
 $J_3$ : Inertia due to object (kg·m<sup>2</sup>)  
 $J_4$ : Inertia due to belt (kg·m<sup>2</sup>)  
 $D_1$ : Diameter of cylinder 1 (mm)  
 $D_2$ : Diameter of cylinder 2 (mm)  
 $M_1$ : Mass of cylinder 1 (kg)  
 $M_2$ : Mass of cylinder 2 (kg)  
 $M_3$ : Mass of object (kg)  
 $M_4$ : Mass of belt (kg)

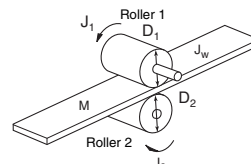

$$J_w = J_1 + \left( \frac{D_1}{D_2} \right)^2 J_2 + \frac{M \cdot D_1^2}{4} \times 10^{-6} \text{ (kg}\cdot\text{m}^2\text{)}$$

$J_w$ : Inertia of entire system (kg·m<sup>2</sup>)  
 $J_1$ : Inertia of roller 1 (kg·m<sup>2</sup>)  
 $J_2$ : Inertia of roller 2 (kg·m<sup>2</sup>)  
 $D_1$ : Diameter of roller 1 (mm)  
 $D_2$ : Diameter of roller 2 (mm)  
 $M$ : Effective mass of workpiece (kg)

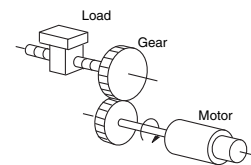

$$J_L = J_1 + G^2 (J_2 + J_w) \text{ (kg}\cdot\text{m}^2\text{)}$$

$J_L$ : Motor shaft conversion load inertia (kg·m<sup>2</sup>)  
 $J_1$ : Load inertia (kg·m<sup>2</sup>)  
 $J_2$ : Motor gear inertia (kg·m<sup>2</sup>)  
 $J_w$ : Load gear inertia (kg·m<sup>2</sup>)  
 $Z_1$ : Number of gear teeth on motor side  
 $Z_2$ : Number of gear teeth on load side  
 Gear ratio  $G = Z_1/Z_2$

### Calculating the Motor Shaft Conversion Torque and Effective Torque

Calculate the total combined torque required for the motor to operate based on the acceleration torque due to the motor shaft conversion load inertia (calculated above) and the load torque due to friction force and the external force applied to the load.

#### Acceleration Torque

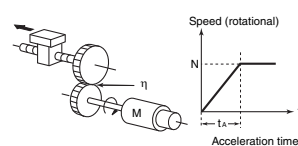

Acceleration Torque ( $T_A$ )

$$T_A = \frac{2\pi N}{60 t_a} \left( J_w + \frac{J_L}{\eta} \right) \text{ (N}\cdot\text{m)}$$

$T_A$ : Acceleration Torque (N·m)  
 $J_L$ : Motor shaft conversion load inertia (kg·m<sup>2</sup>)  
 $J_w$ : Inertia of motor itself (kg·m<sup>2</sup>)  
 $\eta$ : Gear transmission efficiency  
 $N$ : Motor speed (r/min)

#### Motor Conversion Load Torque (External and Friction)

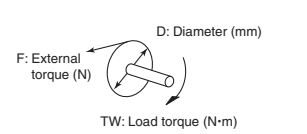

$$T_w = F \cdot \frac{D}{2} \times 10^{-3} \text{ (N}\cdot\text{m)}$$

Friction force in general:

$$F = \mu W$$

$\mu$ : Friction coefficient  
 $W$ : Weight of moving parts

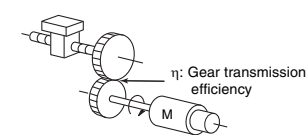

$$T_L = T_w \cdot \frac{G}{\eta} \text{ (N}\cdot\text{m)}$$

$T_L$ : Motor shaft conversion load torque (N·m)  
 $T_w$ : Load torque (N·m)  
 $Z_1$ : Number of gear teeth on motor side  
 $Z_2$ : Number of gear teeth on load side  
 Gear (reduction) ratio  $G = Z_1/Z_2$

## Calculating the Combined Torque and Effective Torque

Effective torque:  $T_{RMS}$  (N·m)

$$= \sqrt{\frac{\sum(T_i)^2 \cdot t_i}{\sum t_i}} = \sqrt{\frac{T_1^2 \cdot t_1 + T_2^2 \cdot t_2 + T_3^2 \cdot t_3 + T_4^2 \cdot t_4}{t_1 + t_2 + t_3 + t_4}}$$

Maximum torque:  $T_{MAX} = T_1 = T_A + T_L$

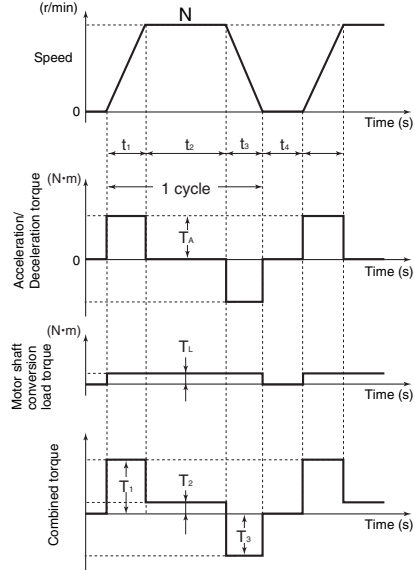

\* Use the Servomotor's Motor Selection Software to calculate the motor conversion inertia, effective torque, and maximum torque shown above.

## Selecting the Motor

Use the results of the calculations above and the equations below to determine the required motor capacity from the effective torque and maximum torque. Use the larger of the following motor capacities when selecting the motor.

When selecting the motor, set a motor capacity higher than the calculated capacity to provide some extra capacity.

### Motor Capacity Supplied for Effective Torque:

Motor capacity (kW):  $1.048 \cdot N \cdot T_{RMS} \cdot 10^{-4}$   
(N: Max. speed in r/min)

### Motor Capacity Supplied for Maximum Torque:

Motor capacity (kW):  $1.048 \cdot N \cdot T_{RMS} \cdot 10^{-4} / 1.5$   
(N: Max. speed in r/min)

## Selecting the Inverter Capacity

Select an Inverter that is large enough to handle the motor selected in Selecting the Motor above. Basically, select an Inverter with a maximum motor capacity that matches the motor capacity calculated above.

After selecting the Inverter, verify that the following conditions are satisfied. If the conditions are not satisfied, select the Inverter that is one size larger and check the conditions again.

- Motor's rated current  $\leq$  Inverter's rated output current
- The application's continuous maximum torque output time  $\leq$  1 minute

- Note:**
1. If the Inverter's overload endurance is 120% of the rated output current for one minute, check for 0.8 minute.
  2. When using the 0-Hz sensorless vector control, or a torque with a min. rating of 150% is frequently used under the condition that the holding torque is required with the rotation speed 0 (r/min), use an inverter with one size larger capacity than the inverter selection result.

## Overview of Braking Resistor Selection

### Applications Requiring Braking Resistors

In applications where excessive regenerative motor energy is produced during deceleration or descent, the main-circuit voltage in the Inverter may rise high enough to damage the Inverter. Standard Inverters, which are equipped with the overvoltage protection function, detect the overvoltage protection and stop operation, which will prevent any damage. Although the Inverter will be protected, the overvoltage protection function will generate an error and the motor will stop; this system configuration will not provide stable continuous operation.

This regenerative energy needs to be emitted to the outside of the Inverter using the braking resistor or regenerative braking unit.

### About Regenerative Energy

The load connected to the motor has kinetic energy if it is rotating or potential energy if it is at a high level. The kinetic or potential energy is returned to the Inverter when the motor decelerates or lowers the load. This phenomenon is known as regeneration and the returned energy is called regenerative energy.

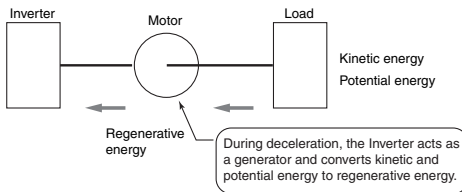

### Avoiding the Use of a Braking Resistor

The following methods can be used to avoid having to connect a Braking Resistor. These methods require the deceleration time to be extended, so you must evaluate whether extending the deceleration time will cause any problems in the application.

- Enable the "stall prevention during deceleration" function; the default setting for this function is enabled. (Increase the deceleration time automatically so as not to generate the overvoltage protection.)
- Set a longer deceleration time. (This reduces the rate at which the regenerative energy is produced.)
- Select "coast to stop" as the stopping method. (Regenerative energy will not be returned to the Inverter.)

### Simple Method for Braking Resistor Selection

This is a simple method for determining the braking resistance from the percentage of time that regenerative energy is produced during a normal operating pattern.

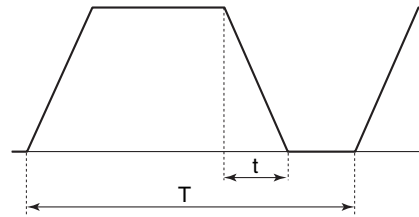

$$\text{Use rate (duty)} = t/T \times 100 (\%ED)$$

t: Deceleration time (regenerative time)  
T: Time for 1 cycle of operation

### For Models with a Built-in Braking Circuit (3G3MX/3G3RX Max. 18.5 kW)

Select the braking resistor based on the usage rate calculated from the operation patterns.

Refer to the braking resistor list described in the User's manual and catalog, and connect it according to your Inverter.

### For Models without a Built-in Braking Circuit (3G3JX/3G3RX Min. 22 kW)

Select the regenerative braking unit and the braking resistor. Refer to the regenerative braking unit and braking resistor lists described in the User's manual and catalog, and connect them according to your Inverter.

## Detailed Method for Braking Resistor Selection

If the Braking Resistor's use rate (duty factor) exceeds 10% ED or the application requires an extremely large braking torque, use the following method to calculate the regenerative energy and select a Braking Resistor.

### Calculating the Required Braking Resistance

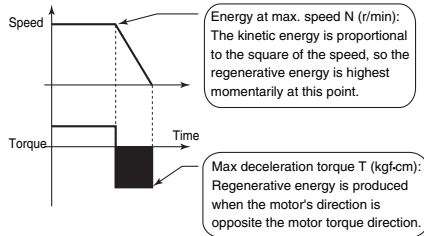

$$\text{Braking Resistor's resistance: } R \leq \frac{V^2}{1.048 \times (T - 0.2 \times T_m) \times N \times 10^{-1}}$$

V: 385 V for a 200-V Class Inverter  
400 V for a 400-V Class Inverter  
T: Maximum braking torque (kgf·cm)  
T<sub>m</sub>: Motor's rated torque (N·cm)  
N: Maximum speed (r/min)

\* Use the value for the braking torque calculated in *Calculating the Motor Shaft Conversion Torque and Effective Torque* on page 27.

### Calculating the Average Regenerative Energy

Regenerative energy is produced when the motor is rotating in the opposite direction of the motor torque. Use the following equations to calculate the regenerative energy produced in each segment of the cycle.

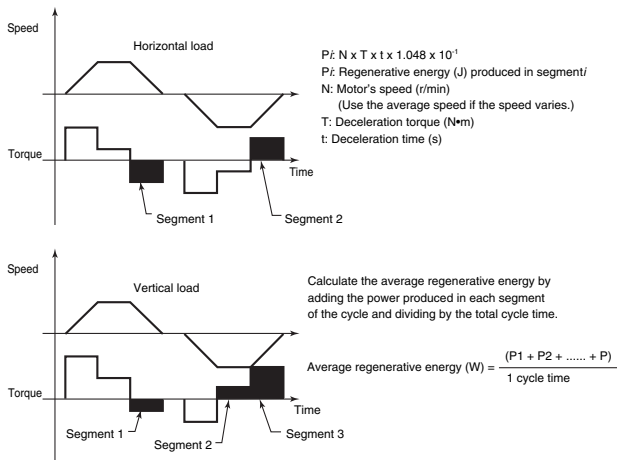

- Note:**
- The speed is positive when the motor is rotating forward and the torque is positive when it is in the forward direction.
  - Use the value for the braking torque calculated in *Calculating the Motor Shaft Conversion Torque and Effective Torque* on page 27.

### Selecting the Braking Resistor

Select the appropriate Braking Resistor based on the required braking resistance and average regenerative energy that were calculated above.

- Required braking resistance  $\geq$  Braking Resistor's resistance  $\geq$  Inverter or Braking Unit's minimum resistance
- Average regenerative energy  $\leq$  Braking Resistor's allowable power

- Note:**
- The internal braking transistor will be damaged if a resistor is connected with a resistance below the Inverter or Regenerative Braking Unit's minimum resistance. If the required resistance is less than the minimum resistance, increase the Inverter's capacity and replace the Inverter or Regenerative Braking Unit with one that has a minimum resistance less than the required resistance.
  - Two or more Regenerative Braking Units can be connected in parallel. Use the following equation to determine the braking resistance when driving two or more Units.  
Braking resistance ( $\Omega$ ) = (required braking resistance calculated above)  $\times$  (number of Units)
  - Do not select the braking resistance with the results calculated above. A rating of 150 W is not the allowed power, it is the maximum rated power in resistance units. The actual allowed power rating depends upon the resistor.