

# 3G3JX

## Compact & Complete

- V/f controlled AC Drive
- Side by side mounting
- Built-in EMC filter
- Built-in RS-485 Modbus
- Overload detection function (150% during 60s)
- PID
- Micro-surge voltage suppression
- Automatic energy saving
- Emergency shut-off
- Second motor setting
- Auto carrier-frequency reduction
- PTC thermistor input
- Cooling fan switch control
- PC configuration tool: CX-Drive
- CE, UL, cUL, RoHS

## Ratings

- 200 V Class single-phase, 0.2 to 2.2 kW (1/4 to 3 HP)
- 200 V Class three-phase, 0.2 to 7.5 kW (1/4 to 10 HP)
- 400 V Class three-phase, 0.4 to 7.5 kW (1/2 to 10 HP)



## System Configuration

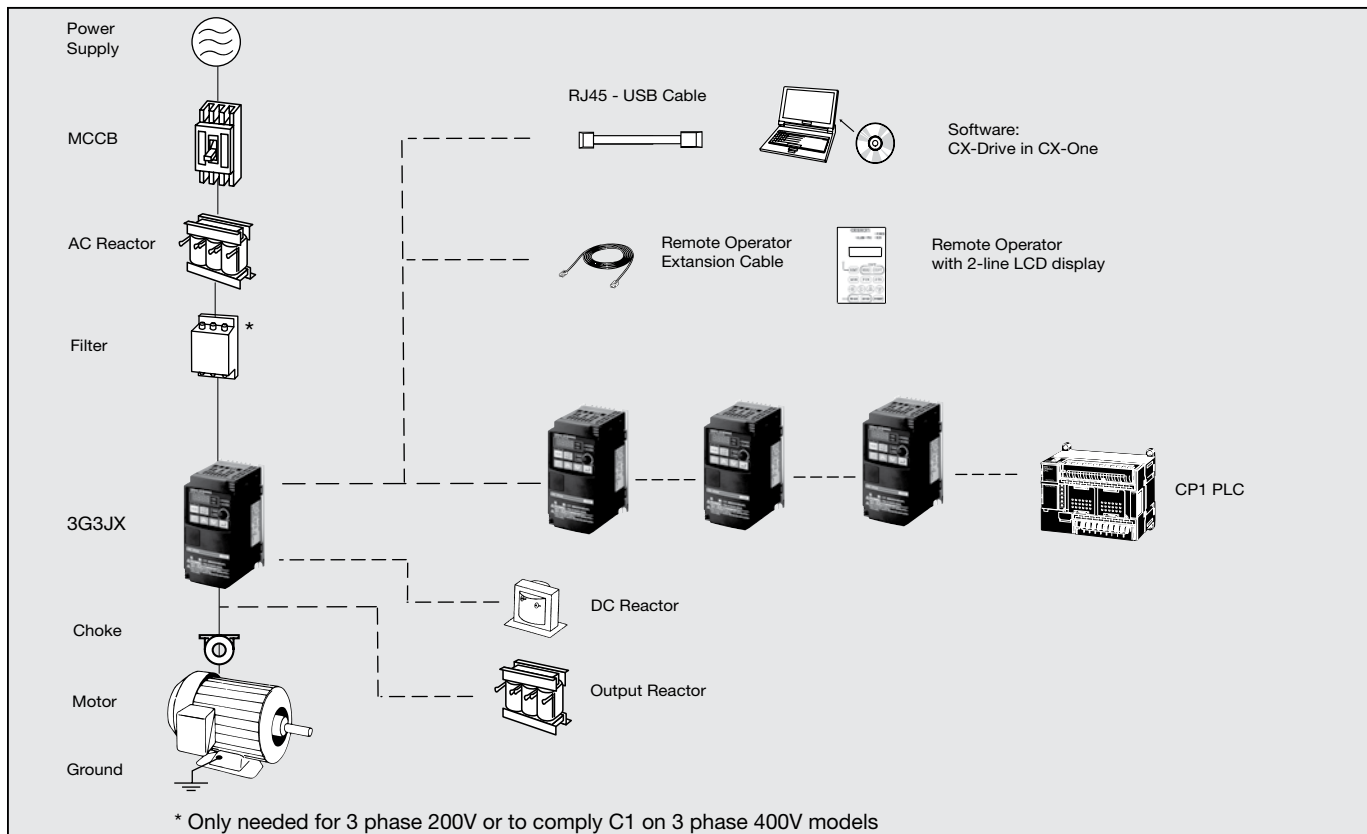

Specifications

Type Designation

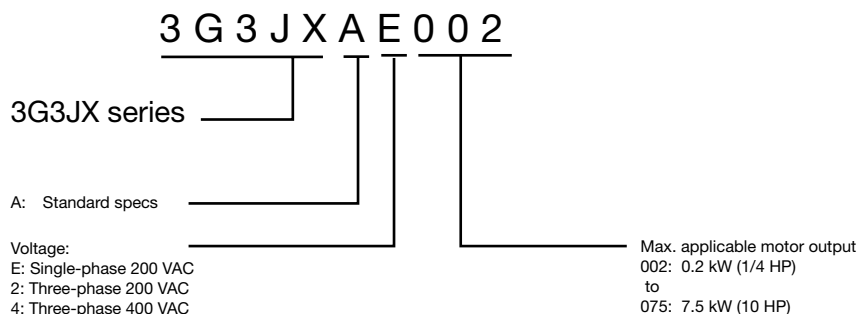

200 V class

Single-phase 3G3JX-□		AE002	AE004	AE007	AE015	AE022	-	-	-	
Three-phase 3G3JX-□		A2002	A2004	A2007	A2015	A2022	A2037	A2055	A2075	
Applicable motor capacity <sup>1</sup>	kW	0.2	0.4	0.75	1.5	2.2	3.7	5.5	7.5	
	HP	1/4	1/2	1	2	3	5	7 1/2	10	
Output characteristics	Inverter capacity kVA	200 V	0.4	0.9	1.3	2.4	3.4	5.5	8.3	11.0
		240 V	0.5	1.0	1.6	2.9	4.1	6.6	9.9	13.3
	Rated output current (A)		1.4	2.6	4	7.1	10	15.9	24	32
	Max. output voltage		Proportional to input voltage: 0 to 240 V							
Max. output frequency		400 Hz								
Power supply	Rated input voltage and frequency		Single-phase 200 to 240 V 50/60 Hz				3-phase 200 to 240 V 50/60 Hz			
	Rated input current (A)		1.8	3.4	5.2	9.3	13.0	20.0	30.0	40.0
	Allowable voltage fluctuation		-15% to +10%							
	Allowable frequency fluctuation		+5%							
Built-in filter		EMC filter (C1 single phase)								
Braking torque	At short-time deceleration At capacitor feedback	Approx. 50%			50% for 3-phase 20 to 40% for 1-phase	Approx 20% to 40%		Approx 20%		
Cooling method		Self cooling			Forced-air-cooling					

Note: 1. Based on a standard 3-Phase standard motor.

400 V class

Three-phase 3G3JX-□		A4004	A4007	A4015	A4022	A4037	A4055	A4075		
Applicable motor capacity <sup>1</sup>	kW	0.4	0.75	1.5	2.2	3.7	5.5	7.5		
	HP	1/2	1	2	3	5	7 1/2	10		
Output characteristics	Inverter capacity kVA	380 V	0.9	1.6	2.5	3.6	5.6	8.5	10.5	
		480 V	1.2	2.0	3.1	4.5	7.1	10.8	13.3	
	Rated output current (A)		1.5	2.5	3.8	5.5	8.6	13.0	16.0	
	Max. output voltage		Proportional to input voltage: 0 to 480 V							
Max. output frequency		400 Hz								
Power supply	Rated input voltage and frequency		3-phase 380 to 480 V 50/60 Hz							
	Rated input current (A)		2.0	3.3	5.0	7.0	11.0	16.5	20.0	
	Allowable voltage fluctuation		-15% to +10%							
	Allowable frequency fluctuation		+5%							
Built-in filter		EMC filter C2 class								
Braking torque	At short-time deceleration At capacitor feedback	Approx. 50%			Approx 20% to 40%			Approx 20%		
Cooling method		Self cooling			Forced-air-cooling					

Note: 1. Based on a standard 3-Phase standard motor.

Specifications

Common specifications

Model number 3G3JX-□	Specifications	
Control functions	Control methods	Phase-to-phase sinusoidal modulation PWM (V/f)
	Output frequency range	0.5 to 400 Hz
	Frequency precision	Digital set value: ±0.01% of the max. frequency
		Analog set value: ±0.4% of the max. frequency (25 ±10°C)
	Resolution of frequency set value	Digital set value: 0.1 Hz
		Analog set value: 1/1000 of maximum frequency
	Resolution of output frequency	0.1 Hz
	Overload capability	150% rated output current for one minute
Frequency set value	0 to 10 VDC (10KΩ), 4 to 20mA (250Ω), frequency setting volume (selectable), RS485 Modbus	
V/f Characteristics	Constant/ reduced torque	
Functionality	Inputs signals	FW (forward), RV (reverse), CF1 to CF4 (multi-step speed), JG (jogging), DB (external DC injection braking), SET (2nd function), 2CH (2-step acceleration/deceleration), FRS (free run), EXT (external trip), USP (USP function), SFT (soft lock), AT (analog current input function selection), RS (reset), PTC (thermistor input), STA (3-wire startup), STP (3-wire stop), F/R (3-wire forward/reverse), PID (PID selection), PIDC (PID integral reset), UP (UP of UP/DWN function), DWN (DWN of UP/DWN function), UDC (data clear of UP/DWN function), OPE (forced OPE mode), ADD (frequency addition), F-TM (forced terminal block), RDY (operation ready), SP-SET (special setting), EMR (emergency shutoff)
	Output signals	RUN (signal during operation), FA1 (frequency arrival signal 1), FA2 (frequency arrival signal 2), OL (overload warning signal), OD (PID excess deviation signal), AL (alarm signal), DC (analog input disconnection detection signal), FBV (PID FB status output), NDc (network error), LOG (logical operation result), ODc (communication option disconnected), LOC (light load signal)
	Standard functions	AVR function, V/f characteristic selection, upper/lower limit, 16-step speeds, starting frequency adjustment, jogging operation, carrier frequency adjustment, PID control, frequency jump, analog gain/bias adjustment, S-shape acceleration/deceleration, electronic thermal characteristics/level adjustment, retry function, simplified torque boost, trip monitor, soft lock function, frequency conversion display, USP function, 2nd control function, motor rotation speed UP/DOWN, overcurrent suppression function
	Analog inputs	2 analog inputs 0 to 10V (20KΩ), 4 to 20mA (250Ω)
	Accel/Decel times	0.01 to 3000s (line/curve selection), 2nd accel/decel setting available
	Display	Status indicator LED's Run, Program, Power, Alarm, Power, Hz, Amps, Volume Led indicator Digital operator: Available to monitor frequency reference, output current, output frequency
Protection functions	Motor overload protection	Electronic Thermal overload relay and PTC thermistor input
	Instantaneous overcurrent	180% of rated current
	Overload	150% for 1 minute
	Overvoltage	790V for 400V type and 395V for 200V type
	Momentary power loss	Following items are selectable: Alarm, 0 Hz start, frequency output at interruption, maximum frequency
	Cooling fin overheat	Temperature monitor and error detection
	Stall prevention level	Selectable level applicable only at constant speed or during acceleration and constant speed
	Ground fault	Detected at power-on
Ambient conditions	Power charge indication	On when power is supplied to the control part
	Degree of protection	IP20
	Ambient humidity	90% RH or less (without condensation)
	Storage temperature	-20°C to +65°C (short-term temperature during transportation)
	Ambient temperature	-10°C to 50°C (Both the carrier frequency and output current need to be reduced at over 40°C.)
	Installation	Indoor (no corrosive gas, dust, etc.)
	Installation height	Max. 1000 m
Vibration	5.9 m/s <sup>2</sup> (0.6G), 10 to 55 Hz (Complies with the test method specified in JIS C0040 (1999).)	

Dimensions

Figure 1

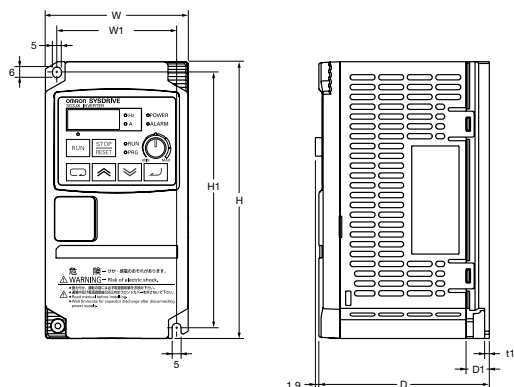
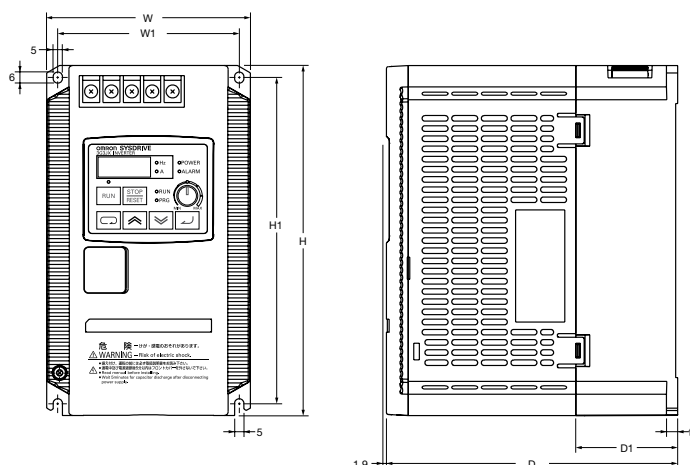

Figure 2



Voltage class	Max. applicable motor output		Inverter model	Figure	Dimensions (Unit: mm)						Weight (kg)	
	kW	HP			W1	H1	W	H	D	t1		D1
Single-phase 200 V	0.2 kW	1/4 HP	3G3JX-AE002	1	67	143	80	155	95.5	2.6	13	0.8
	0.4 kW	1/2 HP	3G3JX-AE004	1					109.5		27	
	0.75 kW	1 HP	3G3JX-AE007	2	98	176	110	189	130.5	6	28	1.5
	1.5 kW	2 HP	3G3JX-AE015	2					157.5		55	
	2.2 kW	3 HP	3G3JX-AE022	2								
Three-phase 200 V	0.2 kW	1/4 HP	3G3JX-A2002	1	67	143	80	155	95.5	2.6	13	0.8
	0.4 kW	1/2 HP	3G3JX-A2004	1					109.5		27	
	0.75 kW	1 HP	3G3JX-A2007	1					132.5		50	
	1.5 kW	2 HP	3G3JX-A2015	2	98	176	110	189	157.5	6	66	2.2
	2.2 kW	3 HP	3G3JX-A2022	2								
	3.7 kW	5 HP	3G3JX-A2037	2	164	235	180	250	167.5	1.6	77.5	4.2
	5.5 kW	7 1/2 HP	3G3JX-A2055	2								
7.5 kW	10 HP	3G3JX-A2075	2									
Three-phase 400 V	0.4 kW	1/2 HP	3G3JX-A4004	2	98	176	110	189	130.5	2.6	28	1.5
	0.75 kW	1 HP	3G3JX-A4007	2								
	1.5 kW	2 HP	3G3JX-A4015	2					157.5		6	
	2.2 kW	3 HP	3G3JX-A4022	2	164	235	180	250	167.5	1.6	77.5	4.2
	3.7 kW	5 HP	3G3JX-A4037	2								
	5.5 kW	7 1/2 HP	3G3JX-A4055	2								
7.5 kW	10 HP	3G3JX-A4075	2									

Line Filters, Footprint Type

Rasmi line filter model		Dimensions (Unit: mm)						Weight (kg)
		W	H	L	X	Y	M	
1x200 V	3G3AX-FIJ1006-RE	81	40	193	183	57	M4	0.5
	3G3AX-FIJ1010-RE	112	47	226	216	88	M4	0.6
	3G3AX-FIJ1026-RE	112	47	226	216	88	M4	0.8
3x200 V	3G3AX-FIJ2006-RE	81	50	193	183	57	M4	1.0
	3G3AX-FIJ2020-RE	112	50	226	216	88	M4	1.3
3x400 V	3G3AX-FIJ2040-RE	182	55	289	279	150	M5	2.3
	3G3AX-FIJ3005-RE	112	45	226	216	88	M4	0.9
	3G3AX-FIJ3011-RE	112	45	226	216	88	M4	1.1
	3G3AX-FIJ3020-RE	182	45	289	279	150	M4	1.7

Note: Filter only needed by the 1-phase 200V or 3-phase 400V to comply with C1 EMC class.

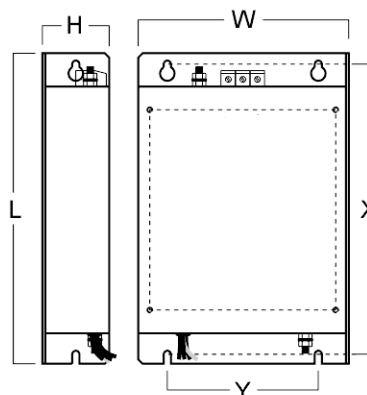

Dimensions

Input AC Reactor

Voltage class	Model 3G3AX-□	Dimensions (Unit: mm)						Weight (kg)
		A	B2	C2	D	E	F	
200 V	RAI02800080-DE	120	70	120	80	52	5.5	1.78
	RAI00880175-DE	120	80	120	80	62	5.5	2.35
	RAI00350335-DE	180	85	190	140	55	6	5.5
400 V	RAI07700042-DE	120	70	120	80	52	5.5	1.78
	RAI03500090-DE	120	80	120	80	62	5.5	2.35
	RAI01300170-DE	120	80	120	80	62	5.5	2.50

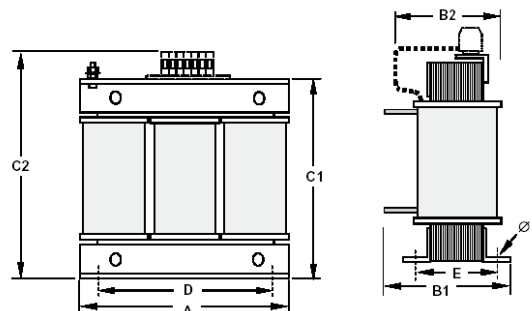

DC Reactor

Voltage class	Model 3G3AX-□	Dimensions (Unit: mm)								Weight (kg)	
		A	B	C	D	E	F	G	H		
200 V	RC21400016-DE	84	113	96	101	66	5	7.5	2	1.22	
	RC10700032-DE			105							
	RC06750061-DE			116							
	RC03510093-DE	108	135	124	120	82	6.5	9.5	-		1.95
	RC02510138-DE			146							
	RC01600223-DE			136							
	RC01110309-DE			146							
RC00840437-DE	84	113	96	101	66	5	7.5	2	1.22		
RC27000030-DE			105								
RC14000047-DE			116								
RC10100069-DE			136								
RC06400116-DE			146								
RC04410167-DE			136								
RC03350219-DE	146										

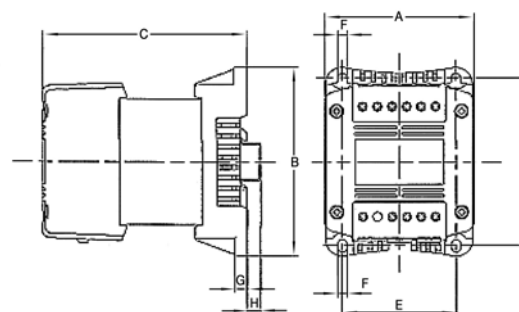

Output AC Reactor

Voltage class	Model 3G3AX-□	Dimensions (Unit: mm)						Weight (kg)
		A	B2	C2	D	E	F	
200 V	RAO11500026-DE	120	70	120	80	52	5.5	1.78
	RAO07600042-DE	120	70	120	80	52	5.5	1.78
	RAO04100075-DE	120	80	120	80	62	5.5	2.35
	RAO03000105-DE	120	80	120	80	62	5.5	2.35
	RAO01830180-DE	180	85	190	140	55	6	5.5
	RAO01150220-DE	180	85	190	140	55	6	5.5
	RAO00950320-DE	180	85	205	140	55	6	6.5
400 V	RAO16300038-DE	120	70	120	80	52	5.5	1.78
	RAO11800053-DE	120	80	120	80	52	5.5	2.35
	RAO07300080-DE	120	80	120	80	62	5.5	2.35
	RAO04600110-DE	180	85	190	140	55	6	5.5
	RAO03600160-DE	180	85	205	140	55	6	6.5

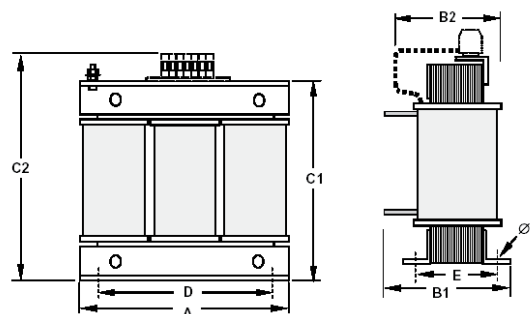

Chokes

Model 3G3AX-□	Diameter	Motor Rating	Dimensions (Unit: mm)						Weight (kg)
	d		L	W	H	X	Y	m	
FER2102-RE	21	< 2.2 kW (3 HP)	85	22	46	70	-	5	0.1
FER2515-RE	25	< 7.5 kW (10 HP)	105	25	62	90	-	5	0.2

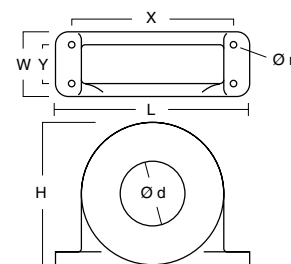

Standard Connections

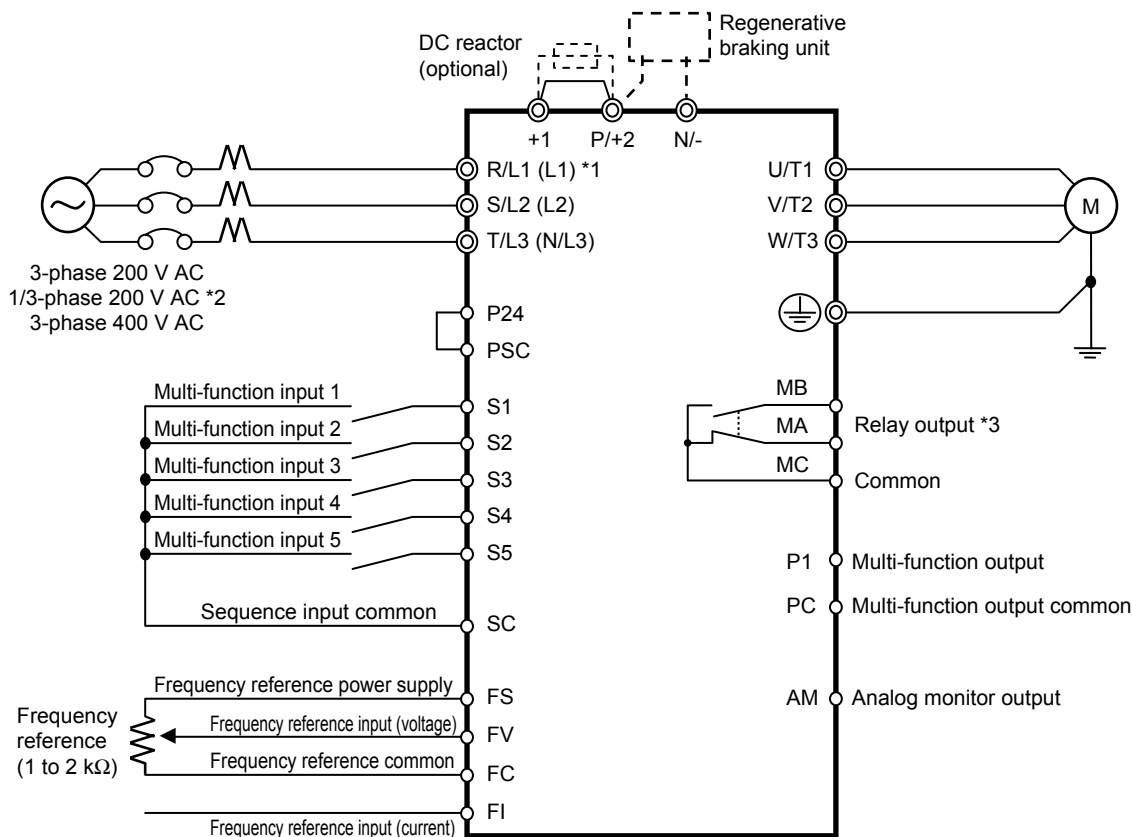

- \*1. The items in parentheses indicate terminal symbols for 3G3JX-AE□□□□.
- \*2. Connect a single-phase 200-V AC input to terminals L1 and N/L3.
- \*3. By factory default, MA is set to NC contact, and MB to NO contact in the relay output (MA, MB) contact selection (C036).

Main Circuit Terminals

Terminal symbol	Terminal name	Function	Connection example
R/L1, S/L2, T/L3*	Main power supply input terminal	Connect the input power supply.	
U/T1, V/T2, W/T3	Inverter output terminal	Connect to the motor.	
+1, P/+2	External DC reactor terminal	Normally connected by the short-circuit bar. Remove the short-circuit bar between +1 and P/+2 when a DC reactor is connected.	
P/+2, N/-	Regenerative braking unit connection terminal	Connect optional regenerative braking units. (If a braking torque is required)	
⊕	Ground terminal	Ground (Connect to ground to prevent electric shock and reduce noise.)	

Note: \*For 3G3JX-AE□□□□'s terminal symbols, R/L1 corresponds to L1, S/L2 to L2, and T/L3 to N/L3. Connect a single-phase 200-V AC input to terminals L1 and N/L3.

## Control Circuit Terminals

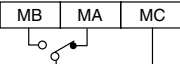
Terminal symbol		Terminal name and function	Default setting		Note	
Input signal	PSC	External power supply terminal for input signal (input) ...At sink logic Internal power supply output terminal for input signal (output) ...At source logic	-		24 V DC $\pm$ 10% 30 mA max.	
	S1	Multi-function input terminals S1 to S5 Select 5 functions among the 31 functions and allocate them to terminals S1 to S5. The terminal allocation is changed automatically when the emergency shutoff function is used.	Forward/Stop		Contact input	
	S2		Reverse/Stop		Close: ON (Start)	
	S3		Fault reset		Open: OFF (Stop)	
	S4		Emergency stop fault		Minimum ON time: 12 ms min.	
	S5		Multi-step speed reference 1			
	SC		Input signal common	-		
Monitor signal	AM	Analog frequency monitor/Analog output current monitor	Analog frequency monitor			
Frequency reference input	FS	Frequency reference power supply	-			
	FV	Voltage frequency reference signal	-		10 V DC, 10 mA max.	
	FI	Current frequency reference signal	-		0 to 10 V DC; Input impedance 10 k $\Omega$ ; When installing variable resistors at FS, FV, and FC (1 to 2 k $\Omega$ )	
	FC	Frequency reference common	-		4 to 20 mA DC; Input impedance 250 $\Omega$	
Output signal	P1	Multi-function output terminal; Select the status of the Inverter and allocate it to terminal P1.	Frequency arrival signal at a constant speed			
	PC	Output signal common	-		27 V DC; 50 mA max.	
Relay output signal	MA	Factory default relay settings	Output terminal	Contact capacity	Resistance load	Inductive load
	MB	Under normal operation: MA-MC Closed	MA-MC	Max.	AC250V 2.5A, DC30V 3A	AC250V 0.2A, DC30V 0.7A
	MC	Under abnormal operation or power shutdown: MA-MC Open 		Min.	AC100V 10mA, DC5V 100mA	
			MB-MC	Max.	AC250V 1A, DC30V 1A	AC250V 0.2A, DC30V 0.2A
				Min.	AC100V 10mA, DC5V 100mA	

### Side by side mounting

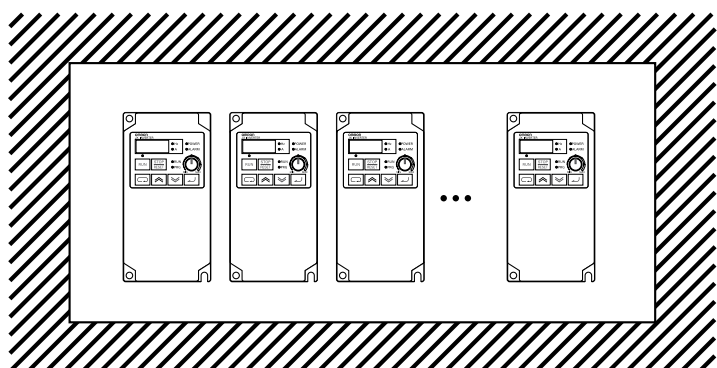

Reactors

Input AC Reactor

3-phase 200 V class				3-phase 400 V class			
Max. applicable motor output	Model 3G3AX-□	Current value	Inductance mH	Max. applicable motor output	Model 3G3AX-□	Current value	Inductance mH
0.1 to 1.5 kW (1/8 to 2 HP)	RAI02800080-DE	8.0 A	2.8	0.4 to 1.5 kW (1/2 to 2 HP)	RAI07700042-DE	4.2 A	7.7
2.2 to 3.7 kW (3 to 5 HP)	RAI00880175-DE	17.5 A	0.88	2.2 to 3.7 kW (3 to 5 HP)	RAI03500090-DE	9.0 A	3.5
5.5 to 7.5 kW (7 1/2 to 10 HP)	RAI00350335-DE	33.5 A	0.35	5.5 to 7.5 kW (7 1/2 to 10 HP)	RAI01300170-DE	17.0 A	1.3

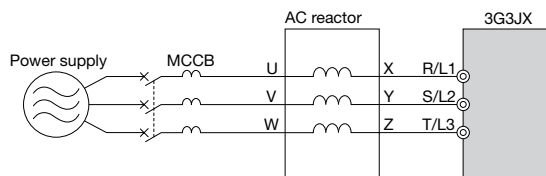

DC Reactor

3-phase 200 V class				3-phase 400 V class			
Max. applicable motor output	Model 3G3AX-□	Current value	Inductance	Max. applicable motor output	Model 3G3AX-□	Current value	Inductance
0.2 kW (1/4 HP)	RC21400016-DE	1.6 A	21.4	-	-	-	-
0.4 kW (1/2 HP)	RC10700032-DE	3.2 A	10.7	0.4 kW (1/2 HP)	RC43000020-DE	2.0 A	43
0.75 kW (1 HP)	RC06750061-DE	6.1 A	6.75	0.75 kW (1 HP)	RC27000030-DE	3.0 A	27
1.5 kW (2 HP)	RC03510093-DE	9.3 A	3.51	1.5 kW (2 HP)	RC14000047-DE	4.7 A	14
2.2 kW (3 HP)	RC02510138-DE	13.8 A	2.51	2.2 kW (3 HP)	RC10100069-DE	6.9 A	10.1
3.7 kW (5 HP)	RC01600223-DE	22.3 A	1.6	3.7 kW (5 HP)	RC06400116-DE	11.6 A	6.4
5.5 kW (7 1/2 HP)	RC01110309-DE	30.9 A	1.11	5.5 kW (7 1/2 HP)	RC04410167-DE	16.7 A	4.41
7.5 kW (10 HP)	RC00840437-DE	43.7 A	0.84	7.5 kW (10 HP)	RC03350219-DE	21.9 A	3.35

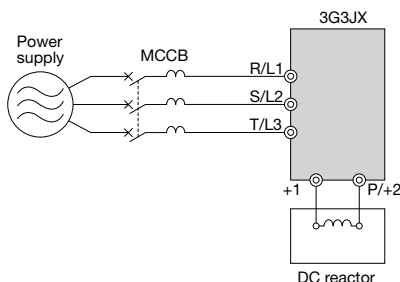

Output AC Reactor

3-phase 200 V class				3-phase 400 V class			
Max. applicable motor output	Model 3G3AX-□	Current value	Inductance	Max. applicable motor output	Model 3G3AX-□	Current value	Inductance
0.1 to 0.4 kW (1/8 to 1/2 HP)	RAO11500026-DE	2.6 A	11.5	0.4 to 1.5 kW (1/2 to 2 HP)	RAO16300038-DE	3.8 A	16.3
0.75 kW (1 HP)	RAO07600042-DE	4.2 A	7.6	2.2 kW (3 HP)	RAO11800053-DE	5.3 A	11.8
1.5 kW (2 HP)	RAO04100075-DE	7.5 A	4.1	3.7 kW (5 HP)	RAO07300080-DE	8 A	7.3
2.2 kW (3 HP)	RAO03000105-DE	10.5 A	3	5.5 kW (7 1/2 HP)	RAO04600110-DE	11 A	4.6
3.7 kW (5 HP)	RAO01830160-DE	16 A	1.83	7.5 kW (10 HP)	RAO03600160-DE	16 A	3.6
5.5 kW (7 1/2 HP)	RAO01150220-DE	22 A	1.15				
7.5 kW (10 HP)	RAO00950320-DE	32 A	0.95				

Ordering Information

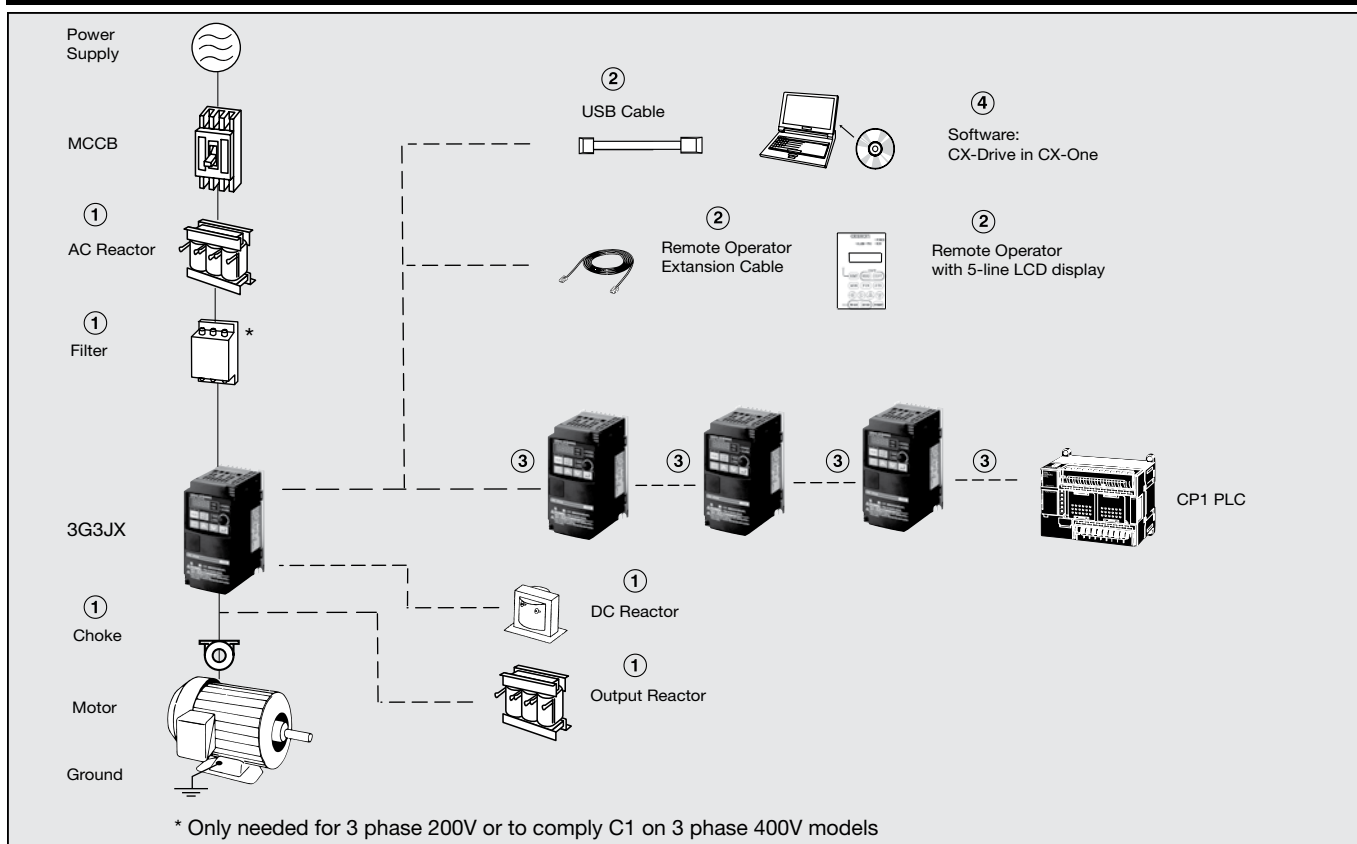

3G3JX AC Drives

Specifications			Model
Voltage class	Max. applicable motor output	Rated output current	Standard
Single-phase 200 V	0.2 kW (1/4 HP)	1.4 A	3G3JX-AE002
	0.4 kW (1/2 HP)	2.6 A	3G3JX-AE004
	0.75 kW (1 HP)	4 A	3G3JX-AE007
	1.5 kW (2 HP)	7.1 A	3G3JX-AE015
	2.2 kW (3 HP)	10 A	3G3JX-AE022
Three-phase 200 V	0.2 kW (1/4 HP)	1.4 A	3G3JX-A2002
	0.4 kW (1/2 HP)	2.6 A	3G3JX-A2004
	0.75 kW (1 HP)	4 A	3G3JX-A2007
	1.5 kW (2 HP)	7.1 A	3G3JX-A2015
	2.2 kW (3 HP)	10 A	3G3JX-A2022
	3.7 kW (5 HP)	15.9 A	3G3JX-A2037
	5.5 kW (7 1/2 HP)	24 A	3G3JX-A2055
	7.5 kW (10 HP)	32 A	3G3JX-A2075
Three-phase 400 V	0.4 kW (1/2 HP)	1.5 A	3G3JX-A4004
	0.75 kW (1 HP)	2.5 A	3G3JX-A4007
	1.5 kW (2 HP)	3.8 A	3G3JX-A4015
	2.2 kW (3 HP)	5.5 A	3G3JX-A4022
	3.7 kW (5 HP)	8.6 A	3G3JX-A4037
	5.5 kW (7 1/2 HP)	13 A	3G3JX-A4055
	7.5 kW (10 HP)	16 A	3G3JX-A4075

① Line Filters

Inverter		Line filter Rasmi		Weight (kg)
Voltage	Model 3G3JX-□	Model 3G3AX-□	Rated current (A)	
1-phase 200 VAC	AE002 / AE004	FIJ1006-RE	6	0.5
	AE007	FIJ1010-RE	10	0.6
	AE015 / AE022	FIJ1026-RE	26	0.8
3-phase 200 VAC	A2002 / A2004 / A2007	FIJ2006-RE	6	1
	A2015 / A2022 / A2037	FIJ2020-RE	20	1.3
	A2055 / A2075	FIJ2040-RE	40	2.3
3-phase 400 VAC	A4004 / A4007 / A4015	FIJ3005-RE	5	0.9
	A4022 / A4037	FIJ3011-RE	11	1.1
	A4055 / A4075	FIJ3020-RE	20	1.7

Ordering Information

① Input AC Reactors

Inverter		AC Reactor
Voltage	Model 3G3JX-□	Model 3G3AX-□
1-phase 200 VAC	AE002 / AE004	Under development
	AE007	
	AE015 / AE022	
3-phase 200 VAC	A2002 / A2004 / A2007	RAI02800080-DE
	A2015 / A2022 / A2037	RAI00880175-DE
	A2055 / A2075	RAI00350335-DE
3-phase 400 VAC	A4004 / A4007 / A4015	RAI07700042-DE
	A4022 / A4037	RAI03500090-DE
	A4055 / A4075	RAI01300170-DE

① DC Reactors

1-phase 200 VAC		3-phase 200 VAC		3-phase 400 VAC	
Inverter	DC Reactor	Inverter	DC Reactor	Inverter	DC Reactor
3G3JX-AB002	3G3AX-RC10700032-DE	3G3JX-A2002	3G3AX-RC21400016-DE	-	-
3G3JX-AB004	3G3AX-RC06750061-DE	3G3JX-A2004	3G3AX-RC10700032-DE	3G3JX-A4004	3G3AX-RC43000020-DE
3G3JX-AB007	3G3AX-RC03510093-DE	3G3JX-A2007	3G3AX-RC06750061-DE	3G3JX-A4007	3G3AX-RC27000030-DE
3G3JX-AB015	3G3AX-RC02510138-DE	3G3JX-A2015	3G3AX-RC03510093-DE	3G3JX-A4015	3G3AX-RC14000047-DE
3G3JX-AB022	3G3AX-RC01600223-DE	3G3JX-A2022	3G3AX-RC02510138-DE	3G3JX-A4022	3G3AX-RC10100069-DE
-	-	3G3JX-A2037	3G3AX-RC01600223-DE	3G3JX-A4037	3G3AX-RC06400116-DE
-	-	3G3JX-A2055	3G3AX-RC01110309-DE	3G3JX-A4055	3G3AX-RC04410167-DE
-	-	3G3JX-A2075	3G3AX-RC00840437-DE	3G3JX-A4075	3G3AX-RC03350219-DE

① Chokes

Model	Diameter (mm)	Description
3G3AX-FER2102-RE	21	For 2.2 kW (3 HP) motors or below
3G3AX-FER2515-RE	25	For 7.5 kW (10 HP) motors or below

① Output AC Reactor

Inverter		AC Reactor
Voltage	Model 3G3JX-□	Model 3G3AX-□
200 VAC	A2002 / A2004 / AE002 / AE004	RAO11500026-DE
	A2007 / AE007	RAO07600042-DE
	A2015 / AE015	RAO04100075-DE
	A2022 / AE022	RAO03000105-DE
	A2037	RAO01830160-DE
	A2055	RAO01150220-DE
	A2075	RAO00950320-DE
400 VAC	A4004 / A4007 / A4015	RAO16300038-DE
	A4022	RAO11800053-DE
	A4037	RAO07300080-DE
	A4055	RAO04600110-DE
	A4075	RAO03600160-DE

② Accessories

Types	Model	Description	Functions
Digital operator	3G3AX-OP05	LCD remote operator	2 Line LCD remote operator with copy function, cable length max. 3m.
	3G3AX-CAJOP300-EE	Remote operator cable	3 meters cable for connecting remote operator
Accessories	3G3AX-CONV1	USB converter / USB cable	RJ45 to USB connection cable

⑤ Computer Software

Item	Description	Functions
CX-Drive	AC Drive/Servo Programming software	Set, transfer and compare parameters; perform test runs and adjustment; perform monitoring and data tracing for Omron inverters and servos included in CX-One software.
CX-One	All-in-one Automation software	Program, configure and simulate operations for PLCs, HMIs, networks, motion control systems, temperature and process controllers.

Note: Software runs on the following OS: Windows 2000 (Service Pack 3a or higher), XP, Vista or Windows 7.

ALL DIMENSIONS SHOWN ARE IN MILLIMETERS.  
To convert millimeters into inches, multiply by 0.03937. To convert grams into ounces, multiply by 0.03527.

Specifications are subject to change without notice.

---

**Note:** This datasheet is provided as a guideline for selecting products. Do not use this document to operate the Unit.

**ALL DIMENSIONS SHOWN ARE IN MILLIMETERS.**

To convert millimeters into inches, multiply by 0.03937. To convert grams into ounces, multiply by 0.03527.

# OMRON

**OMRON ELECTRONICS LLC • THE AMERICAS HEADQUARTERS**

Schaumburg, IL USA • 847.843.7900 • 800.556.6766 • [www.omron247.com](http://www.omron247.com)

**OMRON CANADA, INC. • HEAD OFFICE**

Toronto, ON, Canada • 416.286.6465 • 866.986.6766 • [www.omron247.com](http://www.omron247.com)

**OMRON ELETRÔNICA DO BRASIL LTDA • HEAD OFFICE**

São Paulo, SP, Brasil • 55.11.2101.6300 • [www.omron.com.br](http://www.omron.com.br)

**OMRON ELECTRONICS MEXICO SA DE CV • HEAD OFFICE**

Apodaca, N.L. • 52.811.156.99.10 • 001.800.556.6766 • [mela@omron.com](mailto:mela@omron.com)

**OMRON ARGENTINA • SALES OFFICE**

Cono Sur • 54.11.4783.5300

**OMRON CHILE • SALES OFFICE**

Santiago • 56.9.9917.3920

**OTHER OMRON LATIN AMERICA SALES**

54.11.4783.5300

© 2009 Omron Electronics LLC

Cat. No. I110E-EN-01B

01/10

Specifications are subject to change without notice.