

USER'S MANUAL

3G3AX-PG

Encoder Feedback Board

Introduction

Thank you for choosing the 3G3AX-PG Board. This User's Manual (hereinafter called "this manual") describes the parameter setting methods required for installation/wiring and operation of the 3G3AX-PG model, as well as troubleshooting and inspection methods.

- This manual should be delivered to the actual end user of the product.
- After reading this manual, keep it handy for future reference.
- This manual describes the specifications and functions of the product as well as the relations between them. You should assume that anything not described in this manual is not possible with the product.
- Intended readers
This manual is intended for:
Those with knowledge of electrical systems (qualified electrical engineers or the equivalent), and also in charge of:
 - Introducing the control equipment
 - Designing the control system
 - Installing and/or connecting the control equipment
 - Field management

Read and Understand This Manual

Please read and understand this manual before using the product. Please consult your OMRON representative if you have any questions or comments.

Warranty and Limitations of Liability

WARRANTY
<p>OMRON's exclusive warranty is that the products are free from defects in materials and workmanship for a period of one year (or other period if specified) from date of sale by OMRON.</p> <p>OMRON MAKES NO WARRANTY OR REPRESENTATION, EXPRESS OR IMPLIED, REGARDING NON-INFRINGEMENT, MERCHANTABILITY, OR FITNESS FOR PARTICULAR PURPOSE OF THE PRODUCTS. ANY BUYER OR USER ACKNOWLEDGES THAT THE BUYER OR USER ALONE HAS DETERMINED THAT THE PRODUCTS WILL SUITABLY MEET THE REQUIREMENTS OF THEIR INTENDED USE. OMRON DISCLAIMS ALL OTHER WARRANTIES, EXPRESS OR IMPLIED.</p>

LIMITATIONS OF LIABILITY
<p>OMRON SHALL NOT BE RESPONSIBLE FOR SPECIAL, INDIRECT, OR CONSEQUENTIAL DAMAGES, LOSS OF PROFITS OR COMMERCIAL LOSS IN ANY WAY CONNECTED WITH THE PRODUCTS, WHETHER SUCH CLAIM IS BASED ON CONTRACT, WARRANTY, NEGLIGENCE, OR STRICT LIABILITY.</p> <p>In no event shall the responsibility of OMRON for any act exceed the individual price of the product on which liability is asserted.</p> <p>IN NO EVENT SHALL OMRON BE RESPONSIBLE FOR WARRANTY, REPAIR, OR OTHER CLAIMS REGARDING THE PRODUCTS UNLESS OMRON'S ANALYSIS CONFIRMS THAT THE PRODUCTS WERE PROPERLY HANDLED, STORED, INSTALLED, AND MAINTAINED AND NOT SUBJECT TO CONTAMINATION, ABUSE, MISUSE, OR INAPPROPRIATE MODIFICATION OR REPAIR.</p>

Application Considerations

SUITABILITY FOR USE

OMRON shall not be responsible for conformity with any standards, codes, or regulations that apply to the combination of products in the customer's application or use of the products.

At the customer's request, OMRON will provide applicable third party certification documents identifying ratings and limitations of use that apply to the products. This information by itself is not sufficient for a complete determination of the suitability of the products in combination with the end product, machine, system, or other application or use.

The following are some examples of applications for which particular attention must be given. This is not intended to be an exhaustive list of all possible uses of the products, nor is it intended to imply that the uses listed may be suitable for the products:

- Outdoor use, uses involving potential chemical contamination or electrical interference, or conditions or uses not described in this manual.
- Nuclear energy control systems, combustion systems, railroad systems, aviation systems, medical equipment, amusement machines, vehicles, safety equipment, and installations subject to separate industry or government regulations.
- Systems, machines, and equipment that could present a risk to life or property.

Please know and observe all prohibitions of use applicable to the products.

NEVER USE THE PRODUCTS FOR AN APPLICATION INVOLVING SERIOUS RISK TO LIFE OR PROPERTY WITHOUT ENSURING THAT THE SYSTEM AS A WHOLE HAS BEEN DESIGNED TO ADDRESS THE RISKS, AND THAT THE OMRON PRODUCTS ARE PROPERLY RATED AND INSTALLED FOR THE INTENDED USE WITHIN THE OVERALL EQUIPMENT OR SYSTEM.

PROGRAMMABLE PRODUCTS

OMRON shall not be responsible for the user's programming of a programmable product, or any consequence thereof.

Disclaimers

CHANGE IN SPECIFICATIONS

Product specifications and accessories may be changed at any time based on improvements and other reasons.

It is our practice to change model numbers when published ratings or features are changed, or when significant construction changes are made. However, some specifications of the products may be changed without any notice. When in doubt, special model numbers may be assigned to fix or establish key specifications for your application on your request. Please consult with your OMRON representative at any time to confirm actual specifications of purchased products.

DIMENSIONS AND WEIGHTS

Dimensions and weights are nominal and are not to be used for manufacturing purposes, even when tolerances are shown.

PERFORMANCE DATA

Performance data given in this manual is provided as a guide for the user in determining suitability and does not constitute a warranty. It may represent the result of OMRON's test conditions, and the users must correlate it to actual application requirements. Actual performance is subject to the OMRON Warranty and Limitations of Liability.

ERRORS AND OMISSIONS

The information in this manual has been carefully checked and is believed to be accurate; however, no responsibility is assumed for clerical, typographical, or proofreading errors, or omissions.

Safety Precautions

■ Indications and Meanings of Safety Information

In this user's manual, the following precautions and signal words are used to provide information to ensure the safe use of the 3G3AX-PG Board.

The information provided here is vital to safety. Strictly observe the precautions provided.

■ Meanings of Signal Words



WARNING

Indicates an imminently hazardous situation which, if not avoided, is likely to result in serious injury or may result in death. Additionally there may be severe property damage.



CAUTION

Indicates a potentially hazardous situation which, if not avoided, may result in minor or moderate injury, or in property damage.

■ Alert Symbols in This Document



WARNING



Turn off the power supply and implement wiring correctly.
Not doing so may result in a serious injury due to an electric shock.



Wiring work must be carried out only by qualified personnel.
Not doing so may result in a serious injury due to an electric shock.



Do not touch the surface of the PG Board or terminals, and do not remove the encoder wire or the PG Board while the power is being supplied.
Doing so may result in a serious injury due to an electric shock or fire.



Turn off the input power of the Inverter and wait for more than 10 minutes before putting on or taking off the PG Board, changing the setting / wiring or conducting inspection.
Not doing so may result in a serious injury due to an electric shock.



CAUTION



Place covers on the openings or take other precautions to make sure that no metal objects such as cutting bits or lead wire scraps go inside when installing the PG Board and wiring.



Install a stop motion device to ensure safety. Not doing so might result in a minor injury.



Do not dismantle, repair or modify the product. Doing so may result in an injury.

Precautions for Safe Use

■ Installation and Storage

Do not store or use the product in the following places.

- Locations subject to direct sunlight.
- Locations subject to ambient temperature exceeding the specifications.
- Locations subject to relative humidity exceeding the specifications.
- Locations subject to condensation due to severe temperature fluctuations.
- Locations subject to corrosive or flammable gases.
- Locations subject to exposure to combustibles.
- Locations subject to dust (especially iron dust) or salt.
- Locations subject to exposure to water, oil, or chemicals.
- Locations subject to shock or vibration.

■ Transportation, Installation, and Wiring

Observe the following instructions during transportation, installation, and wiring.

- Do not drop or apply a strong impact on the product. Doing so may result in damaged parts or malfunction.
- Connect the PG Board to the Inverter tightly with the provided fixing screws.
Tighten securely the terminal screws for the encoder wire on the PG Board.
Tightening torque : 0.9 N·m (1.0 N·m max.)
- Be sure to use the provided ferrite cores. Fix the ferrite cores on the wire or take appropriate measures so that the ferrite cores will not cover the shield coating of the wire.
Not doing so may cause the Inverter to malfunction.
- Fix the shielding wire properly or take appropriate measures so that the wire will not be weighed down.
Not doing so may result in shielding wire breakage due to the weight of the ferrite cores.
- Check whether the motor rotation direction is correct, and unusual sound or vibration occurs during operation.

■ Maintenance and Inspection

Be sure to confirm safety before conducting maintenance, inspection or parts replacement.

Precautions for Correct Use

Rated Voltage

Confirm that the power voltage for the encoder is the same as the rated voltage (+5 V DC) of the product.

Product Disposal

Comply with the local ordinance and regulations when disposing of the product.

Revision History

A manual revision code appears as a suffix to the catalog number located at the lower left of the front and back covers.

Cat.No.	I564-E1-01
----------------	-------------------

↑
Revision code

Revision code	Revision date	Changes and revision pages
01	April 2008	First printing

About This Manual

This User's Manual is compiled chapter by chapter for user's convenience as follows:
Understanding the following configuration ensures more effective use of the product.

Chapter		Overview
Chapter 1	Overview	Describes the functional block diagram of the product.
Chapter 2	Design	Describes the mounting method of the product, terminal names, and wiring.
Chapter 3	Operation	Describes the parameters related to the product and precautions for operation.
Chapter 4	Functions	Describes the parameter functions.
Chapter 5	Maintenance Operations	Describes the causes and their countermeasures if the Inverter fails.
Chapter 6	Specifications	Describes the product specifications.

Contents

Introduction.....	1
Read and Understand This Manual.....	2
Safety Precautions	5
Precautions for Safe Use.....	6
Precautions for Correct Use	7
Checking Before Unpacking	8
Revision History.....	9
About This Manual.....	10
Chapter 1 Overview	
1-1 Overview.....	1-1
Chapter 2 Design	
2-1 Mounting the PG Board	2-1
2-2 Terminal Arrangement.....	2-2
2-3 Terminal Functions	2-3
2-4 Wiring.....	2-4
2-5 Connection Diagram	2-6
2-6 Switch Settings	2-8
2-7 Switch Setting Flow Chart.....	2-9
Chapter 3 Operation	
3-1 Related Parameters.....	3-1
3-2 Precautions for Operation.....	3-8
Chapter 4 Functions	
4-1 V2 Control Mode Selection	4-1
4-2 Sensor Vector Control (speed control)	4-2
4-3 Pulse Train Position Control Mode	4-6
4-4 Absolute Position/High-resolution Absolute Position Control Modes	4-15
Chapter 5 Maintenance Operations	
5-1 Operation Selection During Option Error	5-1
5-2 Cause and Countermeasure of Option Errors	5-2
5-3 Warning Display.....	5-3
Chapter 6 Specifications	
6-1 Product Specifications	6-1

Chapter 1

Overview

1-1 Overview	1-1
--------------------	-----

1-1 Overview

The PG Board (3G3AX-PG01) is an optional board for the 3G3RX Series Inverter. With this board, you can realize highly accurate system operation with minimum speed fluctuation, and position control via pulse train position command input by detecting the rotation speed of the motor with an encoder and using the data for feedback.

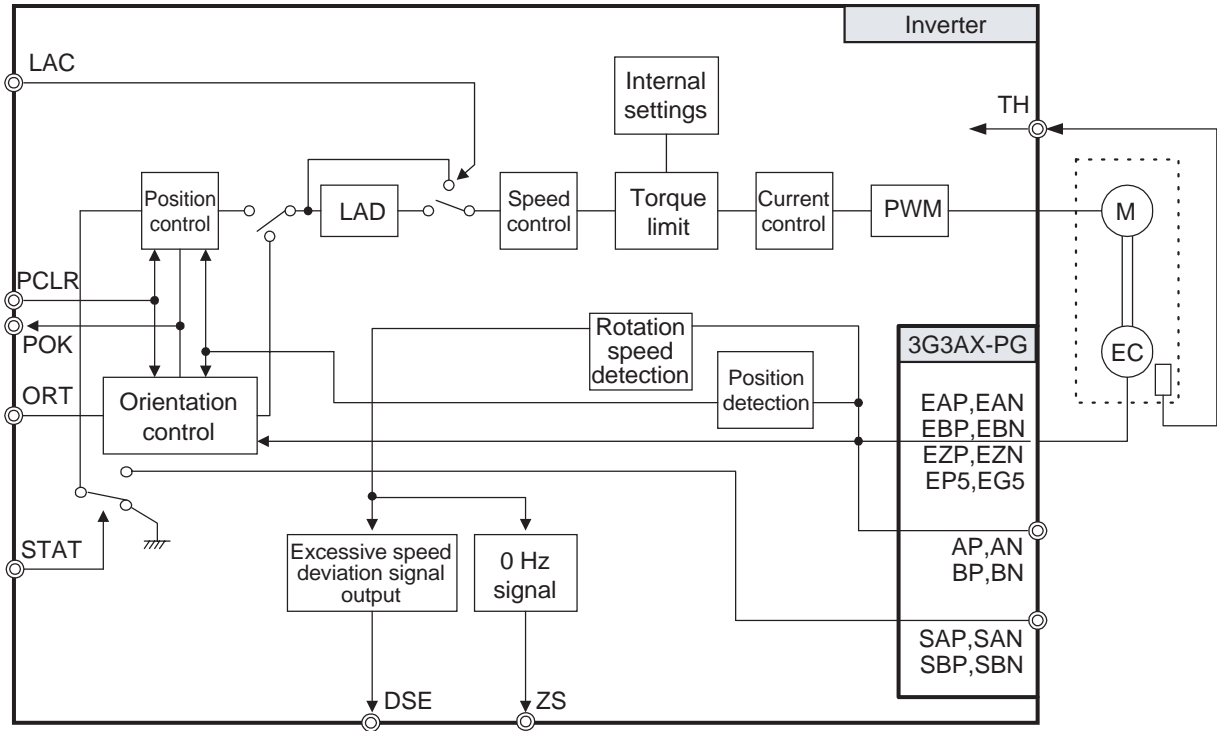

Chapter 2

Design

2-1	Mounting the PG Board	2-1
2-2	Terminal Arrangement.....	2-2
2-3	Terminal Functions	2-3
2-4	Wiring	2-4
2-5	Connection Diagram	2-6
2-6	Switch Settings	2-8
2-7	Switch Setting Flow Chart.....	2-9

2-1 Mounting the PG Board

2

Securely mount the PG Board as shown below.

Place the four holes (in the corners) and the connector (on the back) of the PG Board on Board port 1 (or port 2) correctly, with the two holes on the guideposts and the other two on the screw holes.

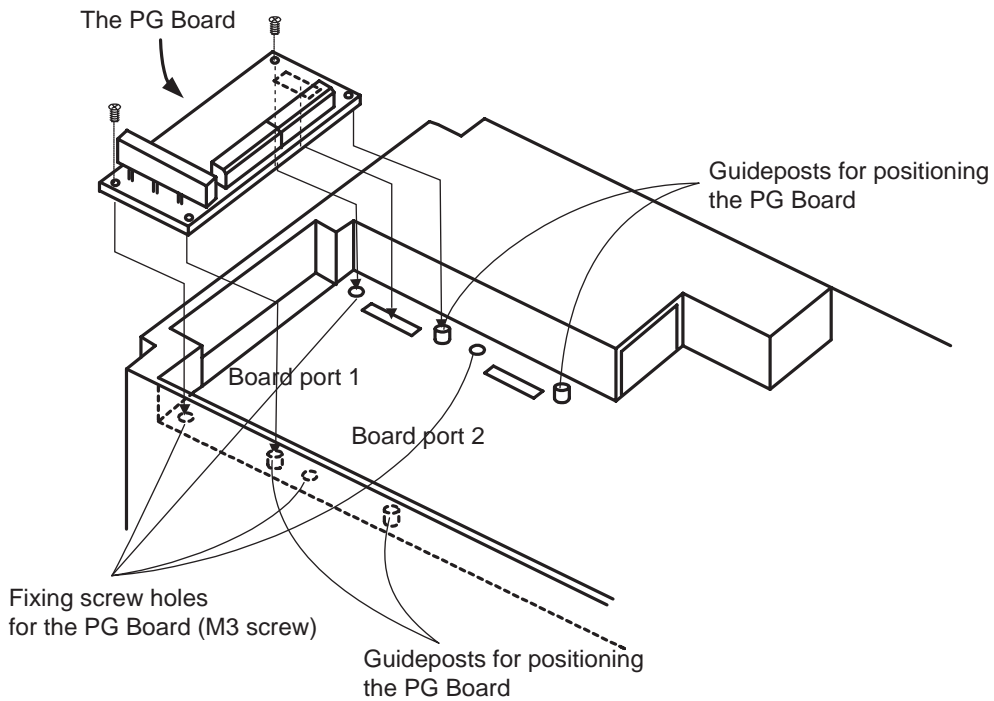

Precautions for Correct Use

To mount the PG Board, be sure to tightly fix it with the two provided fixing screws after putting in place the connector securely. Otherwise, the Inverter will not operate properly.

2-2 Terminal Arrangement

The terminal arrangement on the PG Board is shown below.

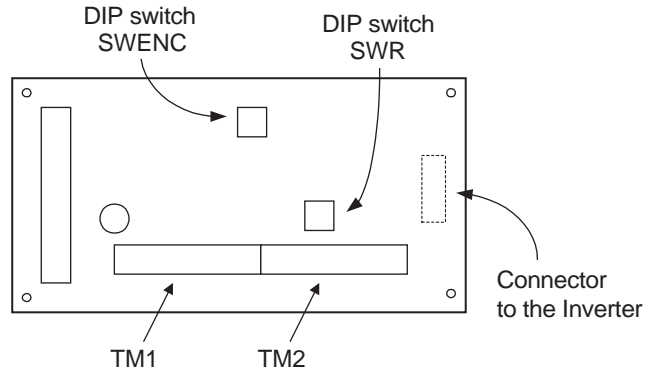

TM1 terminal arrangement

EP5	EG5	EAP	EAN	EBP	EBN	EZP	EZN
-----	-----	-----	-----	-----	-----	-----	-----

TM2 terminal arrangement

SAP	SAN	SBP	SBN	AP	AN	BP	BN
-----	-----	-----	-----	----	----	----	----

2-3 Terminal Functions

2

Design

Terminal symbol	Terminal name	Functions	Electric specifications	
Input terminal	SAP SAN SBP SBN	Pulse train position command input	<ul style="list-style-type: none"> •Pulse train mode selection (P013)*1 Mode 0: Pulse train with 90° phase difference Mode 1: Forward/Reverse command + Pulse train Mode 2: Forward pulse train + Reverse pulse train •Built-in termination resistor can be set enabled or disabled using the DIP switch on the PG Board. (Built-in termination resistance: 150Ω) 	5V DC Receiver input (Complies with RS-422)
	EAP EAN EBP EBN EZP EZN	Encoder signal input	A, B, Z: Encoder signal input	Photocoupler input (Compatible with the rotary encoder of 5V DC line driver output type)
Output terminal	AP AN BP BN	Encoder signal output	Outputs the encoder signal input by the pulse ratio (1:1).	5V DC line driver output (Complies with RS-422)
	EP5 EG5 (Common)	Encoder power supply	+5 V DC power supply	150 mA max.

*1 Use the Inverter parameters for the pulse train mode selection.

2-4 Wiring

Wiring Length of Encoder Cable

Do not exceed 20 m for the wiring length of the encoder cable. If the wiring length should be 20 m or longer by necessity, use a relay amplifier that specifies 5 V line driver output. In this case, be careful of the following points for wiring.

- ♦To use a relay amplifier, the wiring length between the PG Board and the relay amplifier must be within 20 m. Check the input specifications of the relay amplifier to determine the wiring length between the relay amplifier and encoder. (Confirm with the relay amplifier manufacturer.)
If the wiring length is longer than that specified, the Inverter could work erroneously due to influence from the outside noise at that point. Be careful of the relay amplifier wiring.

- ♦The encoder cable could be easily influenced by outside noise depending on the shielding method of the shield cable, resulting in an Inverter failure. Generally connect to the power supply ground of a signal line or to the ground for shielding. (To connect to the ground, be careful of the ground cabling route and avoid multi-point grounding.)

To use a PG Board encoder power supply for the interface power supply between the PG Board and relay amplifier, adopt a shielding method following "Mounting the Ferrite Cores" (page 2-5). A different method can be applied, however, for the power supply from a source other than the PG Board. If using a relay amplifier, also follow "Mounting the Ferrite Cores" (page 2-5) for the connection of the ferrite cores.

Mounting the Ferrite Cores

The ferrite core mounting method is shown below.

Mount the two provided ferrite cores as below when connecting the encoder cable.

Connect the wire to the EG5 terminal of the 3G3AX-PG Board through the ferrite cores for shielding.

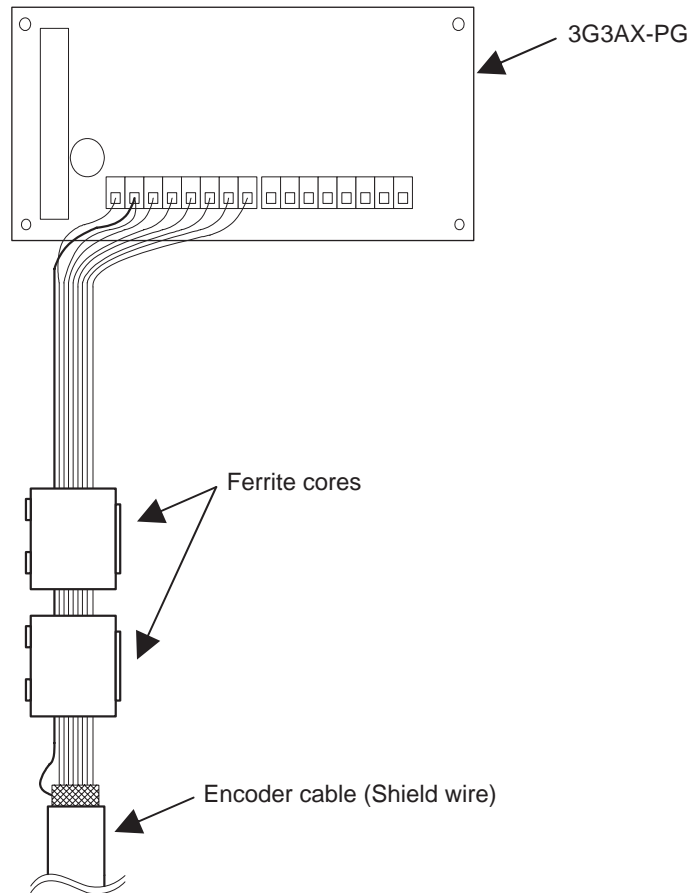

Precautions for Correct Use

If the ferrite cores cover the shield coating, they fail to work effectively, causing the Inverter to malfunction. Be sure to fix the ferrite cores or take other appropriate measures so that they do not overlap the shield coating.

The shield wire connected to the terminal could become disconnected due to the weight of the ferrite cores. Be sure to fix the ferrite cores or take other appropriate measures so that the shield wire does not receive the weight of the ferrite cores.

2-5 Connection Diagram

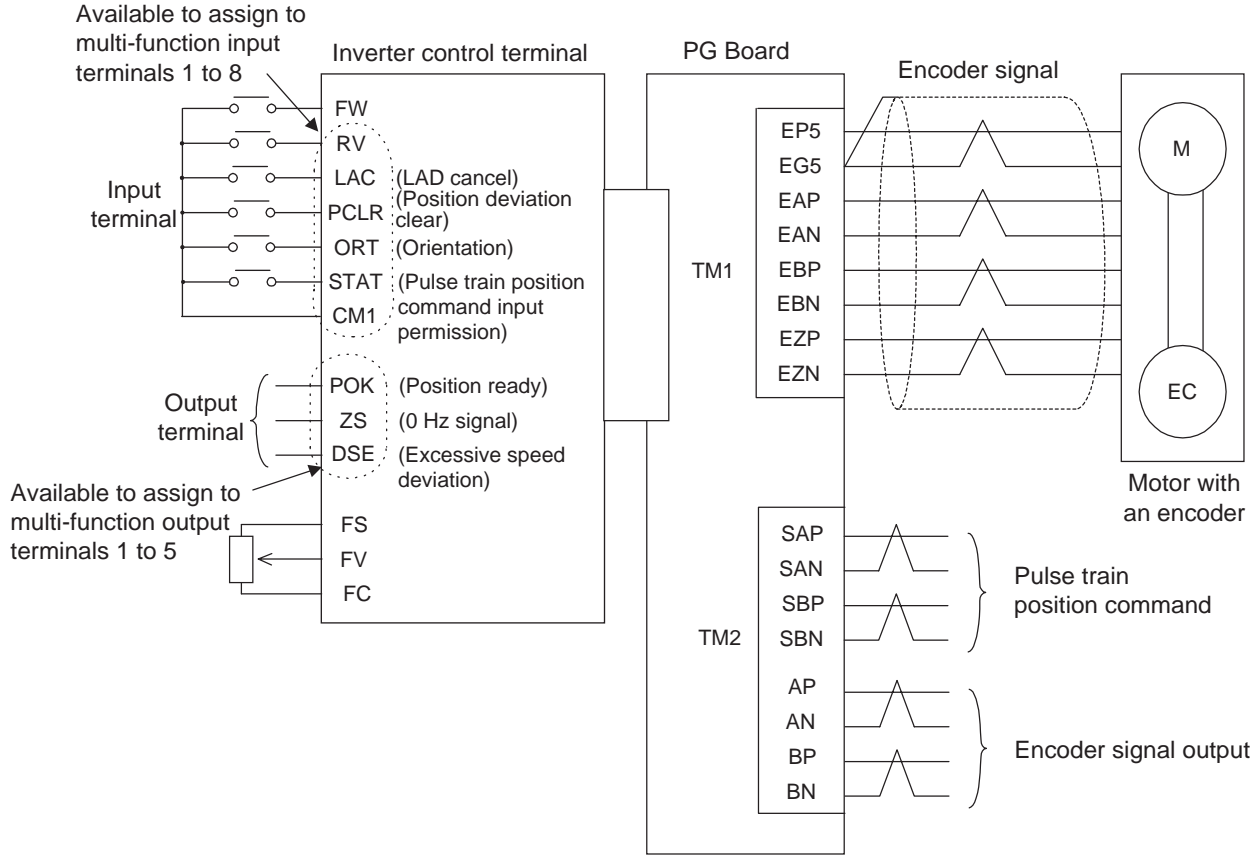

- Note 1: For the terminal connection on the Inverter, refer to the Inverter 3G3RX User's Manual.
- Note 2: For the signal line, use a twisted shield wire and apply the shield coating as illustrated below. Keep the length to 20 m or less. If the wiring length should be 20 m or more by necessity, use a VX application control device RCD-E(remote control device), or CVD-E (insulated type signal converter). For the encoder line, use a twisted shield wire of 0.75 mm² or more. Keep the length to 20 m or less. If the wiring length should be 20 m or longer by necessity, use a relay amplifier that specifies 5 V line driver output.

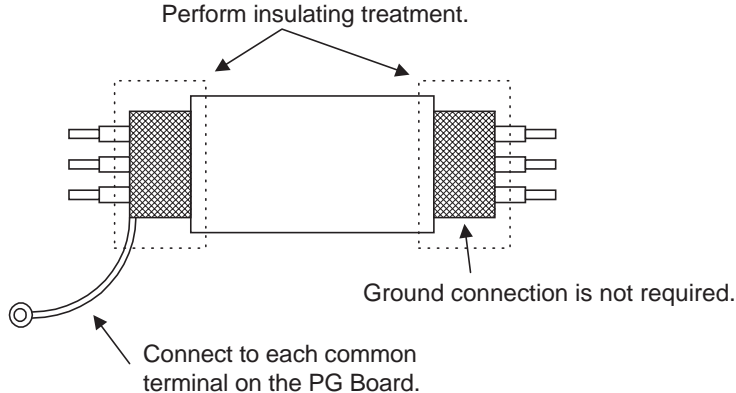

Note 3: Separate the wiring from that of the main circuit and/or the relay control circuit. If they have to be crossed, be sure to cross them at right angles.

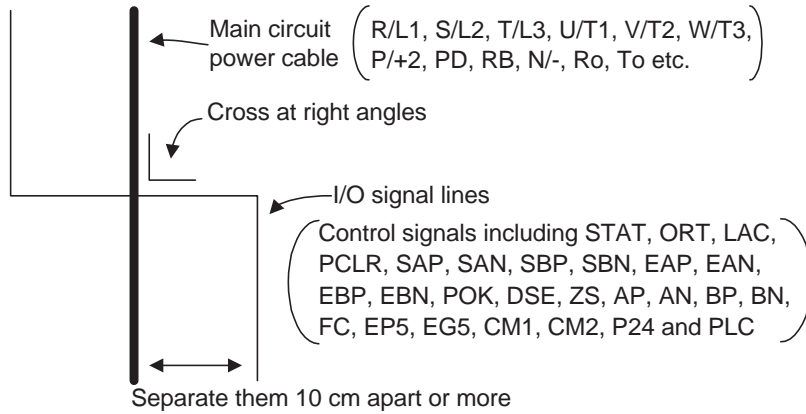

Note 4: Do not short-circuit between the terminals EP5 and EG5 in order to avoid breakage.

Note 5: Insulate between the analog input common terminal "FC" of the Inverter and the common terminal (common) for the encoder signal and such peripheral devices as a sequencer.

Note 6: To connect the encoder signal line, follow the illustration below for phase relations during the rotation of the motor.

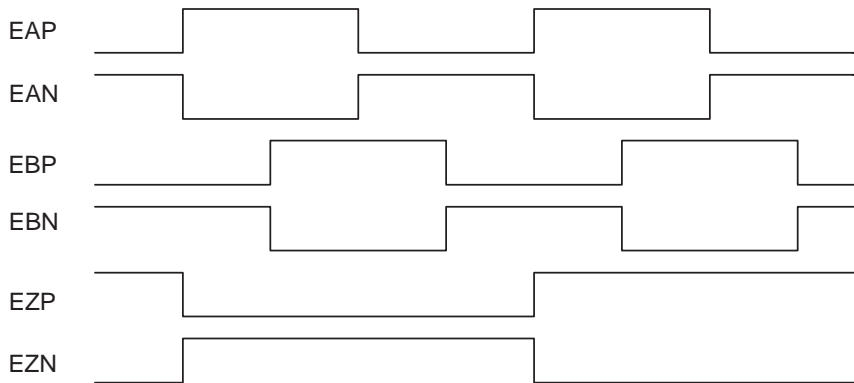

2-6 Switch Settings

Switch Arrangement

The switch arrangement is shown below.

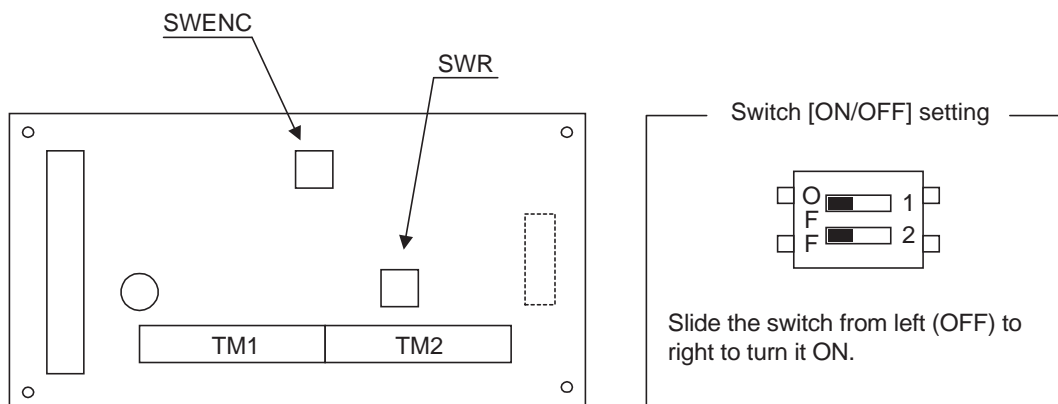

Default Settings

The default settings (factory settings) are shown below.

DIP switch name	Switch No.	Settings		Default setting
SWENC	1	ON	Disconnection detection enabled when encoder A and B phases are not connected	OFF
		OFF	Disconnection detection disabled when encoder A and B phases are not connected	
	2	ON	Disconnection detection enabled when encoder Z phase is not connected	OFF
		OFF	Disconnection detection disabled when encoder Z phase is not connected	
SWR ^{*1}	1	ON	Built-in termination resistor between SAP and SAN (150 Ω) enabled	OFF
		OFF	Built-in termination resistor between SAP and SAN disabled	
	2	ON	Built-in termination resistor between SBP and SBN (150 Ω) enabled	OFF
		OFF	Built-in termination resistor between SBP and SBN disabled	

^{*1} When connecting the multiple units in parallel for pulse train position command inputs, turn ON the SWR1 and SWR2 of the only one unit located farthest from the master unit.

2-7 Switch Setting Flow Chart

2

Design

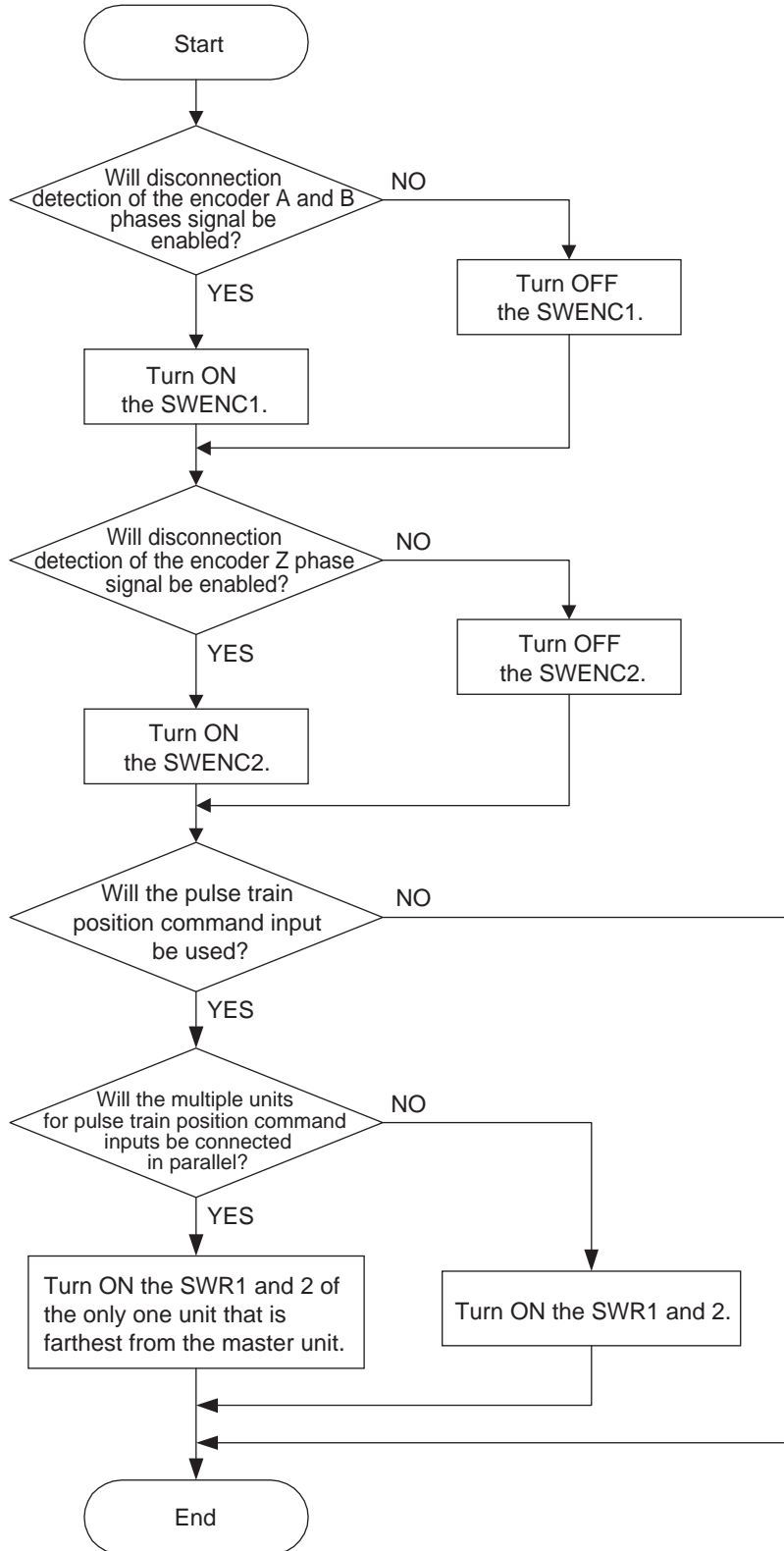

Chapter 3

Operation

3-1	Related Parameters.....	3-1
3-2	Precautions for Operation.....	3-8

3-1 Related Parameters

For details on the parameters, refer to "Chapter 4 Functions" and the Inverter 3G3RX User's Manual.

Parameter No.	Function name	Data range	Default setting (3G3RX-)	Changes during operation	Unit
A001	Frequency reference selection	00: Digital Operator (FREQ adjuster) (Enabled when 3G3AX-OP01 is connected.) 01: Terminal 02: Digital Operator (F001) 03: ModBus communication 04: Option 1 05: Option 2 06: Pulse train frequency 07: Not used 10: Frequency operation result	02	×	—
A002	RUN command selection	01: Terminal 02: Digital Operator (F001) 03: ModBus communication 04: Option 1 05: Option 2	02	×	—
A044	V/f characteristics selection	00: Constant torque characteristics (VC) 01: Special reduced torque characteristics (special VP) 02: Free V/f characteristics 03: Sensorless vector control (SLV) 04: 0-Hz sensorless vector control 05: Sensor vector control (V2)	00	×	—
A076	PID feedback selection	00: FI 01: FV 02: RS485 communication 03: Pulse train frequency 10: Operation function output	00	×	—
A141	Operation frequency input A setting	00: Digital Operator (F001) 01: Digital Operator (FREQ adjuster) (Enabled when 3G3AX-OP01 is connected.) 02: Input FV 03: Input FI	02	×	—
A142	Operation frequency Input B setting	04: RS485 communication 05: Option 1 06: Option 2 07: Pulse train frequency	03	×	—
A145	Frequency addition amount	0.00 to 99.99 100.0 to 400.0	0.00	×	Hz
A146	Frequency addition direction	00: Adds the A145 value to the output frequency 01: Subtracts the A145 value from the output frequency	0.0	×	—

Parameter No.	Function name	Data range	Default setting	Changes during operation	Unit
C001	Multi-function input 1 selection	45: ORT (orientation) 47: PCLR (position deviation clear) 48: STAT (pulse train position command input permission) 50: ADD (frequency addition) 52: ATR (torque reference input permission) 54: SON (servo ON) 66: CP1 (position command selection 1) 67: CP2 (position command selection 2) 68: CP3 (position command selection 3) 69: ORL (zero return limit signal) 70: ORG (zero return startup signal) 71: FOT (forward driving stop) 72: ROT (reverse driving stop) 73: SPD (speed/position switching)	01	×	-
C002	Multi-function input 2 selection		18		
C003	Multi-function input 3 selection		12		
C004	Multi-function input 4 selection		02		
C005	Multi-function input 5 selection		03		
C006	Multi-function input 6 selection		04		
C007	Multi-function input 7 selection		05		
C008	Multi-function input 8 selection		06		
C021	Multi-function output terminal P1 selection	21: ZS (0-Hz signal) 22: DSE(excessive speed deviation) 23: POK (position ready)	00	×	-
C022	Multi-function output terminal P2 selection		01		
C023	Multi-function output terminal P3 selection		03		
C024	Multi-function output terminal P4 selection		07		
C025	Multi-function output terminal P5 selection		40		
C026	Relay output (MA, MB) function selection		05		
H001	Auto-tuning selection	00: Disabled 01: Not rotate 02: Rotate	00	×	-
H002	Motor parameter selection	00: Standard motor parameter 01: Auto-tuning parameter 02: Auto-tuning parameter (Online auto-tuning enabled)	00	×	-
H003	Motor capacity selection	0.20 to 75.00	Default setting	×	kW
H004	Motor pole number selection	2/4/6/8/10	4	×	Pole
H005	Speed response	0.001 to 9.999/10.00 to 80.00 (10.000 to 80.000)	1.590	○	-
H006	Stabilization parameter	0. to 255.	100.	○	-
H020	Motor parameter R1	0.001 to 9.999 10.00 to 65.53	Depends on the motor capacity.	×	Ω

3-1 Related Parameters

Parameter No.	Function name	Data range	Default setting	Changes during operation	Unit
H021	Motor parameter R2	0.001 to 9.999 10.00 to 65.53	Depends on the motor capacity.	×	Ω
H022	Motor parameter L	0.01 to 99.99 100.0 to 655.3	Depends on the motor capacity.	×	mH
H023	Motor parameter I _o	0.01 to 99.99 100.0 to 655.3	Depends on the motor capacity.	×	A
H024	Motor parameter J	0.001 to 9.999 10.00 to 99.99 100.0 to 999.9 1000. to 9999.	Depends on the motor capacity.	×	kgm ²
H030	Motor parameter R1 (auto-tuning data)	0.001 to 9.999 10.00 to 65.53	Depends on the motor capacity.	×	Ω
H031	Motor parameter R2 (auto-tuning data)	0.001 to 9.999 10.00 to 65.53	Depends on the motor capacity.	×	Ω
H032	Motor parameter L (auto-tuning data)	0.01 to 99.99 100.0 to 655.3	Depends on the motor capacity.	×	mH
H033	Motor parameter I _o (auto-tuning data)	0.01 to 99.99 100.0 to 655.3	Depends on the motor capacity.	×	A
H034	Motor parameter J (auto-tuning data)	0.001 to 9.999 10.00 to 99.99 100.0 to 999.9 1000. to 9999.	Depends on the motor capacity.	×	kgm ²
H050	PI proportional gain	0.0 to 999.9 1000.	100.0	○	–
H051	PI integral gain	0.0 to 999.9 1000.	100.0	○	–
H052	P proportional gain	0.01 to 10.00	1.00	○	–
H060	Limit at 0 Hz	0.0 to 100.0	100.0	○	%
H061	Boost amount at SLV startup, 0 Hz	0. to 50.	50.	○	%
H070	For PI proportional gain switching	0.0 to 999.9 1000.	100.0	○	–
H071	For PI integral gain switching	0.0 to 999.9 1000.	100.0	○	–
H072	For P proportional gain switching	0.00 to 10.00	1.00	○	–
H073	Gain switching time	0. to 9999.	100.	○	ms

Parameter No.	Function name	Data range	Default setting	Changes during operation	Unit
P001	Operation selection at option 1 error	00: Trip 01: Continues operation	00	×	–
P002	Operation selection at option 2 error	00: Trip 01: Continues operation	00	×	–
P011	Encoder pulses	128. to 9999. 1000 to 6500 (10000 to 65000)	1024.	×	Pulse
P012	V2 control mode selection	00: ASR (speed control mode) 01: APR (pulse train position control mode) 02: APR2 (absolute position control mode) 03: HAPR (high-resolution absolute position control mode)	00	×	–
P013	Pulse train mode selection	00: Mode 0 01: Mode 1 02: Mode 2	00	×	–
P014	Orientation stop position	0. to 4095.	0.	×	–
P015	Orientation speed setting	Starting frequency to Max. frequency (Upper limit 120.0)	5.00	×	Hz
P016	Orientation direction setting	00: Forward side 01: Reverse side	00	×	–
P017	Position ready range setting	0. to 9999. 1000 (10000)	5.	×	Pulse
P018	Position ready delay time setting	0.00 to 9.99	0.00	×	s
P019	Electronic gear setting position selection	00: Position feedback side (FB) 01: Position command side (REF)	00	×	–
P020	Electronic gear ratio numerator	0. to 9999.	1.	×	–
P021	Electronic gear ratio denominator	0. to 9999.	1.	×	–
P022	Position control feed forward gain	0.00 to 99.99 100.0 to 655.3	0.00	×	–
P023	Position loop gain	0.00 to 99.99 100.0	0.50	×	rad/s
P024	Position bias amount	–204 (–2048.) / –999. to 2048.	0.	○	–

3-1 Related Parameters

Parameter No.	Function name	Data range	Default setting	Changes during operation	Unit
P025	Secondary resistance compensation enable/disable selection	00: Disabled 01: Enabled	00	×	—
P026	Overspeed error detection level	0.0 to 150.0	135.0	×	%
P027	Speed deviation error detection level	0.00 to 99.99 100.0 to 120.0	7.50	×	Hz
P028	Motor gear ratio numerator	1. to 9999.	1.	×	—
P029	Motor gear ratio denominator	1. to 9999.	1.	×	—
P031	Acceleration/deceleration time input type	00: Digital Operator 01: Option 1 02: Option 2	00	×	—
P032	Orientation stop position input type	00: Digital Operator 01: Option 1 02: Option 2	00	×	—
P033	Torque reference input selection	00: Terminal FV 01: Terminal FI 02: Terminal FE 03: Digital Operator	00	×	—
P034	Torque reference setting	0. to 200.	0.	○	%
P035	Polarity selection at torque reference via FE	00: As per sign 01: Depends on the RUN direction	00	×	—
P036	Torque bias mode	00: Disabled 01: Digital Operator 02: Terminal FE	00	×	—
P037	Torque bias value	−200. to +200.	0.	○	%
P038	Torque bias polarity selection	00: As per sign 01: Depends on the RUN direction	00	×	—
P039	Speed limit value in torque control (forward)	0.00 to Max. frequency	0.00	○	Hz
P040	Speed limit value in torque control (reverse)	0.00 to Max. frequency	0.00	○	Hz
P055	Pulse train frequency scale	1.0 to 50.0	25.0	×	kHz
P056	Pulse train frequency filter time constant	0.01 to 2.00	0.10	×	s

Parameter No.	Function name	Data range	Default setting	Changes during operation	Unit
P057	Pulse train frequency bias amount	-100. to +100.	0.	×	%
P058	Pulse train frequency limit	0. to 100.	100.	×	%
P060	Multi-step position command 0	Position range specification (reverse side) to Position range specification (forward side) (Displays MSB 4 digits including “-”)	0	○	-
P061	Multi-step position command 1		0		
P062	Multi-step position command 2		0		
P063	Multi-step position command 3		0		
P064	Multi-step position command 4		0		
P065	Multi-step position command 5		0		
P066	Multi-step position command 6		0		
P067	Multi-step position command 7		0		
P068	Zero return mode	00: Low 01: Hi1 02: Hi2	00	○	-
P069	Zero return direction selection	00: Forward side 01: Reverse side	00	○	-
P070	Low-speed zero return frequency	0.00 to 10.00	0.00	○	Hz
P071	High-speed zero return frequency	0.00 to 99.99 100.0 to Max. frequency	0.00	○	Hz
P072	Position range specification (forward side)	0 to 268435455 (at P012 = 02) 0 to 1073741823 (at P012 = 03) (Displays MSB 4 digits)	268435455	○	-
P073	Position range specification (reverse side)	-268435455 to 0 (at P012 = 02) -1073741823 to 0 (at P012 = 03) (Displays MSB 4 digits)	-268435455	○	-

3-1 Related Parameters

Parameter No.	Function name	Data range	Default setting	Changes during operation	Unit
P074	Teaching selection	00: Multi-step position command 0 (P060) 01: Multi-step position command 1 (P061) 02: Multi-step position command 2 (P062) 03: Multi-step position command 3 (P063) 04: Multi-step position command 4 (P064) 05: Multi-step position command 5 (P065) 06: Multi-step position command 6 (P066) 07: Multi-step position command 7 (P067)	00	○	—

3

Operation

3-2 Precautions for Operation

Operation

For operation, refer to “Chapter 3 Operation” of the Inverter 3G3RX User’s Manual. When operating the RUN command from the terminal block side of the Inverter, follow the procedure below.

1. **Supply power to the Inverter.**
2. **Set the V/f characteristics selection (A044) to “05”.**
3. **Set the necessary items according to “Chapter 4 Functions” of the Inverter 3G3RX User’s Manual.**
4. **For speed control, operation starts according to each setting when the Inverter RUN command is turned ON.**
5. **For position control, turn ON the STAT terminal, and turn ON the Inverter RUN command. When inputting the pulse train position command between SAP and SAN, and between SBP and SBN, the motor rotates according to the input pulse.**

Test Run

Check the following items for a test run.

- Does the motor accelerate normally?
- Is the motor rotation direction correct?
- Is there any abnormal vibration or noise in the motor?

Check whether the phase sequence is correct if the motor does not accelerate normally or an Inverter overload trip is observed in the test run. If the waveform of phase A is 90° ahead of that of phase B in forward rotation, the phase sequence can be said to be normal.

Note 1: In some cases, monitor signal is not output from the “MP” terminal of Inverter if the Inverter runs without the motor connected and with the control method set to “05” (sensor vector control) in the Inverter function mode “A044”. With “05” set, check the motor output after connecting the motor with an encoder.

Note 2: Do not perform free running through the RS terminal allocated to the multifunction input of the Inverter during operation. Otherwise, an overcurrent trip or power element breakage may occur. Use the FRS terminal allocated to the multifunction input of the Inverter for free running during operation.

Note 3: With a large value set for torque limit (b041 - b044), an overcurrent trip may occur during load application. Adjust the torque limit set value to avoid this.

Note 4: Perform auto tuning if the motor parameter is unknown.

3-2 Precautions for Operation

Note 5: If vector control cannot provide the desired characteristics, adjust the motor parameters depending on the phenomenon, according to the table below.

Operation status	Phenomenon	Adjustment method	Adjustment item
During startup	Shock occurs during startup.	Reduce motor parameter J from the set parameter.	H024/H034
During deceleration	Motor hunting occurs.	Reduce the speed response.	H005
		Reduce motor parameter J from the set parameter.	H024/H034
During torque limit	Insufficient torque occurs at low frequency during torque limit	Set an overload limit level lower than the torque limit level.	b021 b041 to b044
Low-frequency operation	Rotation is not constant.	Increase motor parameter J from the set parameter.	H024/H034
High-frequency operation	Torque reduction occurs at high frequency.	Decrease motor parameter I _o . (to approx. 0.7 times)	H023

Chapter 4

Functions

4-1	V2 Control Mode Selection.....	4-1
4-2	Sensor Vector Control (speed control)	4-2
4-3	Pulse Train Position Control Mode	4-6
4-4	Absolute Position/High-resolution Absolute Position Control Modes	4-15

4-1 V2 Control Mode Selection

Select a control method in V2 control mode selection P012.

When “00” (ASR) is selected in P012, speed control mode is enabled. Select a frequency reference in frequency reference selection A001.

When “01” (APR) is selected in P012, the Inverter enables position control by generating frequency reference based on the position command pulse input from the pulse train position command input terminal, and on the position feedback detected by the encoder.

Select any of the three pulse train position command input modes in pulse train mode selection P013.

To perform pulse train position control, allocate “48” (STAT) to any of the multi-function input terminals. While the STAT terminal is tuned on, pulse train position command input is accepted.

Position deviation can be cleared through external input. Allocate “47” (PCLR) to any of the multi-function input terminals. Turning ON/OFF the PCLR terminal can clear position deviation data. Allocating “22” (DSE) to any of the multi-function output terminals enables excessive speed deviation signal output.

Set a deviation level in speed deviation error detection level P027. When the deviation between real frequency and reference frequency exceeds the P027 set value, the DSE signal turns on.

When “02” (APR2) or “03” (HAPR) is selected in P012, the Inverter performs absolute position control with reference to the absolute position from its origin.

Parameter No.	Function name	Data	Default setting	Unit
P012	V2 control mode selection	00: ASR (speed control mode) 01: APR (pulse train position control mode) 02: APR2 (absolute position control mode) 03: HAPR (high-resolution absolute position control mode)	00	–
P011	Encoder pulses	128. to 9999./1000 to 6553 (10000 to 65535): Number of encoder pulses	1024.	Pulse
P023	Position loop gain	0.00 to 99.99/100.0: Position loop gain	0.50	rad/s
P027	Speed deviation error detection level	0.00 to 99.99/100.0 to 120.0: DSE signal output level	7.50	Hz
H004	Motor pole number selection	2/4/6/8/10: Select a motor pole number.	4	Pole
C001 to C008	Multi-function inputs 1 to 8 selection	47: PCLR (position deviation clear) 48: STAT (pulse train position command input permission)	–	–
C021 to C025	Multi-function output terminals P1 to P5 selection	22: DSE (excessive speed deviation)	–	–
C026	Relay output (MA, MB) function selection		05	
Related functions		A001, P013		

4-2 Sensor Vector Control (speed control)

To use this function, set V/f characteristics selection A044 to "05" (V2), and V2 control mode selection P012 to "00" (speed control).

("Sensor vector control" can be selected for 1st control only.)

To use this function, make sure that the motor parameter settings are suitable for your motor. For details, refer to "Chapter 4 Functions, 4-2 Function Mode, Motor Parameter Selection" in the general-purpose Inverter 3G3RX User's Manual.

Also, be sure to set the number of your encoder pulses.

With V2 control mode selection P012, you can select four types of control modes: Speed control, Pulse train position control, Absolute position control, and High-resolution absolute position control. Note the following before use:

- Sufficient characteristics may not be obtained if you select a motor size two or more ranks lower than the motor size specified.
- If the Inverter does not normally accelerate, or if overload protection is activated, check the phase sequence of the encoder signal. (If phase A is advanced by 90° from phase B during forward run, it is judged as being normal.)

When running the Inverter with V/f characteristics selection A044 set to "00" (VC), you can check the rotation direction with real frequency monitor d008.

(If positive frequency is detected when the forward command is activated, or if negative frequency is detected when the reverse command is activated, the rotation direction is judged as being normal.)

If sensor vector control cannot provide the desired characteristics, adjust the motor parameters depending on the phenomenon, as shown in the table below.

Operation status	Phenomenon	Adjustment method	Adjustment item
During startup	Shock occurs during startup.	Reduce motor parameter J from the set parameter.	H024/H034
During deceleration	Motor hunting occurs.	Reduce the speed response.	H005
		Reduce motor parameter J from the set parameter.	H024/H034
During torque limit	Insufficient torque at low frequency during torque limit	Set an overload limit level lower than the torque limit level.	b021 b041 to b044
Low-frequency operation	Rotation is not constant.	Increase motor parameter J from the set parameter.	H024/H034
Related functions		A001, A044, F001, b040, H002, H003, H004, H020, H021, H022, H023, H050, H051, H052, P011, P012	

Note 1: Make sure that the carrier frequency (b083) is not lower than 2.1 kHz. If the carrier frequency is at 2.1 kHz or lower, the Inverter will not operate normally.

Note 2: To use a motor with a capacity lower than that of the Inverter, set a torque limit value (b041 to b044), while keeping the value α in the following formula at 200% or lower. Otherwise, the motor may burn out.

$$\alpha = \text{Torque limit set value} \times (\text{Inverter capacity}) / (\text{Motor capacity})$$

(Example) If the Inverter capacity is 0.75 kW and the motor capacity is 0.4 kW, the torque limit set value for $\alpha = 200\%$, calculated with the above formula, is as follows:

$$\begin{aligned} \text{Torque limit set value (b041 to b044)} &= \alpha \times (\text{Motor capacity}) / (\text{Inverter capacity}) \\ &= 200\% \times (0.4 \text{ kW}) / (0.75 \text{ kW}) = 106\% \end{aligned}$$

Torque Bias Function

This function applies bias to the torque reference generated in speed control, and is useful for elevating applications.

Parameter No.	Function name	Data	Default setting	Unit
P036	Torque bias mode	00: Disabled 01: Set via the Digital Operator 02: Set via terminal FE * ¹	00	–
P037	Torque bias value	–200 to +200: Enabled when P036 = 01	0.	%
P038	Torque bias polarity selection * ²	00: As per sign 01: Depends on the RUN direction	00	–
Related functions	d010			

*1. When torque bias is set to the FE terminal, –10 to +10 (V) is recognized as –200 to +200 (%).

*2. • When “00” (As per sign) is selected:

When the polarity of a torque bias signal is (+), the torque increases for forward rotation, and when it is (–), the torque increases for reverse rotation, regardless of the RUN direction.

• When “01” (Depends on the RUN direction) is selected:

The torque bias signal polarity and torque bias direction vary depending on the RUN command direction.

Forward command: Applies torque in the same direction as the torque bias.

Reverse command: Applies torque in the opposite direction of the torque bias.

Torque Control

This function can be used in torque control, as well as in the speed and pulse train position controls. Torque control can be applied to winders, and more.

To run the Inverter in torque control mode, allocate “52” (ATR) to any of the multi-function inputs. While the ATR terminal is turned on, the torque reference input is enabled.

With torque reference input selection P033, you can select either each analog input or the input via the Digital Operator.

The torque control speed depends on the balance between torque and load. To prevent the Inverter from running out of control, set a speed limit value in P039 (forward) or P040 (reverse).

Parameter No.	Function name	Data	Default setting	Unit
P033	Torque reference input selection	00: Input via terminal FV 01: Input via terminal FI 02: Input via terminal FE 03: Input via the Digital Operator	00	–
P034	Torque reference setting	0 to 200: Torque reference when P033 = 03	0.	%
P035	Polarity selection at torque reference via FE	00: As per sign 01: Depends on the RUN direction	00	–
P039	Speed limit value in torque control (forward)	0.00 to 99.99/100.0 to 400.0	0.00	Hz
P040	Speed limit value in torque control (reverse)	0.00 to 99.99/100.0 to 400.0	0.00	Hz
P036	Torque bias mode	00: Disabled 01: Set via the Digital Operator 02: Set via terminal FE	00	–
P037	Torque bias value	–200 to +200: Enabled when P036 = 01	0.	%
P038	Torque bias polarity selection	00: As per sign 01: Depends on the RUN direction	00	–
C001 to C008	Multi-function inputs 1 to 8 selection	52: ATR (torque reference input permission)	–	–
Related functions	d009, d010, d012			

Control Block Diagram

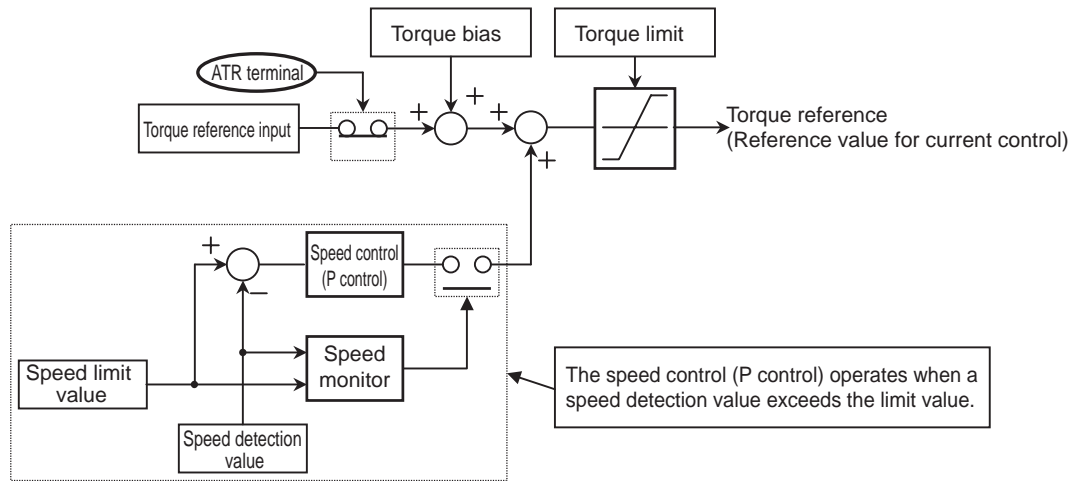

4

Functions

4-3 Pulse Train Position Control Mode

To use this function, set V/f characteristics selection A044 to "05" (V2), and V2 control mode selection P012 to "01" (pulse train position control).

("Sensor vector control" can be selected for 1st control only.)

Select a pulse train position command input mode in pulse train mode selection P013.

Parameter No.	Function name	Data	Default setting	Unit
P012	V2 control mode selection	01: APR (pulse train position control mode)	00	-
P013	Pulse train mode selection	00: Mode 0 (pulse train with 90° phase difference) 01: Mode 1 (forward/reverse command + Pulse train) 02: Mode 2 (Forward pulse train + Reverse pulse train)		
P017	Position ready range setting	0. to 9999./1000 (10000): Set a value equivalent to encoder ×4 multiplication.	5.	-
P018	Position ready delay time setting	0.00 to 9.99	0.00	s
P019	Electronic gear setting position selection	00: FB (feedback side) 01: REF (command side)	00	-
P020	Electronic gear ratio numerator	1. to 9999.	1.	-
P021	Electronic gear ratio denominator	1. to 9999.	1.	-
P022	Position control feed forward gain	0.00 to 99.99/100.0 to 655.3	0.00	-
P023	Position loop gain	0.00 to 99.99/100.0	0.50	rad/s
P024	Position bias amount	-204 (-2048)/-999. to 2048.	0.	-
C001 to C008	Multi-function inputs 1 to 8 selection	47: PCLR (position deviation clear) 48: STAT (pulse train position command input permission)	-	-

Frequency reference for the pulse train position control mode is calculated with the following formula:

$$\text{Frequency reference (Hz)} = \frac{6.4 \times P \times K_v}{\text{ENC}} \times \frac{\Delta P}{255}$$

P	: Number of motor poles
K _v	: Position loop gain
ENC	: Number of encoder pulses
ΔP	: Position deviation

In the position control mode, the acceleration/deceleration time settings are disabled. (The Inverter will be automatically brought into LAD cancel status.)

The higher the position loop-back gain, the shorter the acceleration/deceleration time.

4-3 Pulse Train Position Control Mode

For details on the pulse train input mode, refer to the following.

- Mode 0: pulse train with 90° phase difference

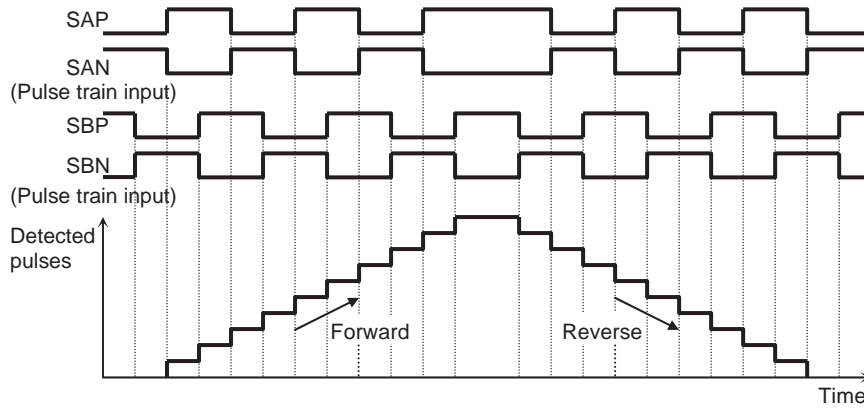

- Mode 1: Forward/Reverse command + Pulse train

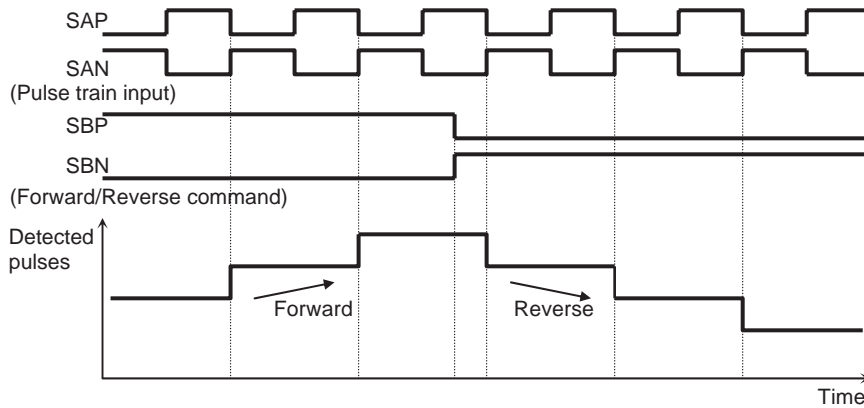

- Mode 2: Forward pulse train + Reverse pulse train

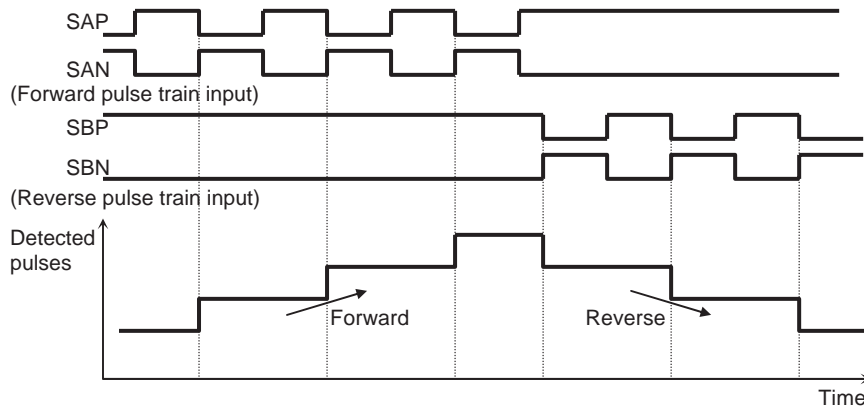

Electronic Gear Function

This function allows you to set a gain relative to position command or position feedback and to change the main/sub motor rotation ratio, particularly for synchronous operation.

Parameter No.	Function name	Data	Default setting	Unit
P019	Electronic gear setting position selection	00: Position feedback side (FB) 01: Position command side (REF)	00	—
P020	Electronic gear ratio numerator *3	1 to 9999	1.	—
P021	Electronic gear ratio denominator *3	1 to 9999	1.	—
P022	Position control feedforward gain *1	0.00 to 655.3	0.00	—
P023	Position loop gain *2	0.00 to 99.99/100.0	0.50	rad/s

Note: Below are the block diagrams of the electronic gear function.

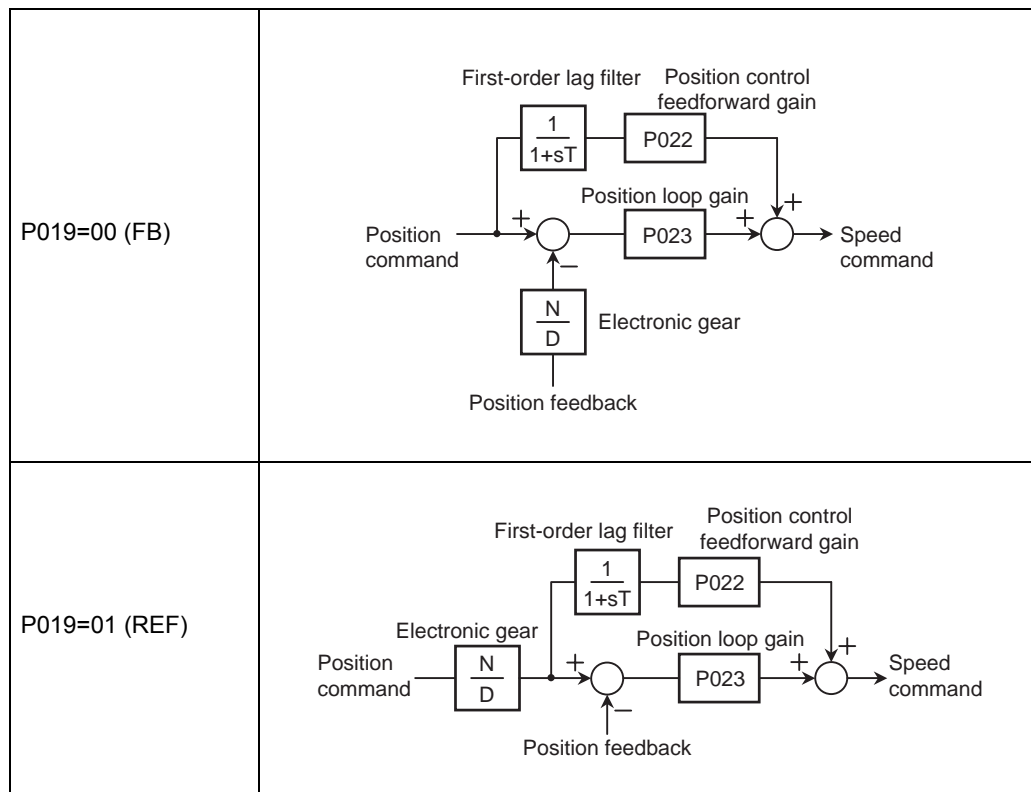

- *1. It is recommended that position control feedforward gain adjustment should be started with P022 = 2.00. To reduce the position deviation between the main and sub motors, increase the position control feedforward gain. If motor hunting occurs, reduce the position control feedforward gain.
- *2. It is recommended that position loop gain adjustment should be started with P023 = 2.00. To increase positioning accuracy and holding power, increase the position loop gain. If an increased position loop gain causes hunting, reduce the position loop gain.
- *3. Make sure that the N/D setting is within the range of $1/50 \leq N/D \leq 20$.
(N: Electronic gear ratio numerator [P020], D: Electronic gear ratio denominator [P021])

Example: Synchronous Operation

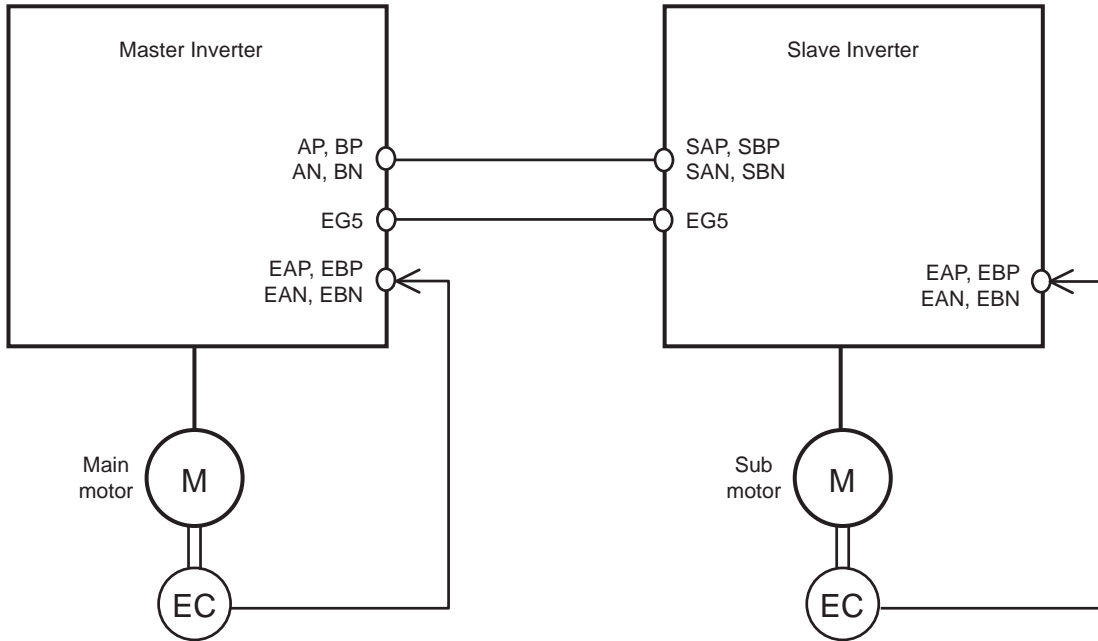

For the Inverter (master Inverter) on the main motor side, you can select either the speed control or pulse train position control mode.
 For the Inverter (slave Inverter) on the sub motor side, you need to select the pulse train position control mode.

Configuration Example

- Main motor : Number of encoder pulses = 1024
- Sub motor : Number of encoder pulses = 3000
- Main motor rpm : Sub motor rpm = 2:1

For operation under the above conditions, set the following data in the slave Inverter.

Pulse train mode selection (P013) : 00 (pulse with 90° phase difference)
 Electronic gear setting position selection (P019) : 01 (REF)
 Electronic gear ratio numerator (P020) : 3000
 Electronic gear ratio denominator (P021) : 1024 × 2 = 2048

The following shows an example of the ratio of slave rpm to master rpm depending on the P019 to P021 settings.

(Note that the same number of encoder pulses (1024 pulses) should be set on both Inverters.)

Electronic gear setting position selection (P019)	REF (Position command side)	REF (Position command side)	FB (Position feedback side)	FB (Position feedback side)
Electronic gear ratio numerator (P020)	1024	2048	1024	2048
Electronic gear ratio denominator (P021)	2048	1024	2048	1024
Slave rpm/ Master rpm	1/2	2	2	1/2

Configuration Example

- Main motor : Number of encoder pulses = 1024
- Sub motor : Number of encoder pulses = 3000
- Main motor rpm : Sub motor rpm = 2:1

For operation under the above conditions, set the following data in the Inverter on the sub motor side.

- Electronic gear setting position selection (P019) : 01 (REF)
- Electronic gear ratio numerator (P020) : 3000
- Electronic gear ratio denominator (P021) : $1024 \times 2 = 2048$

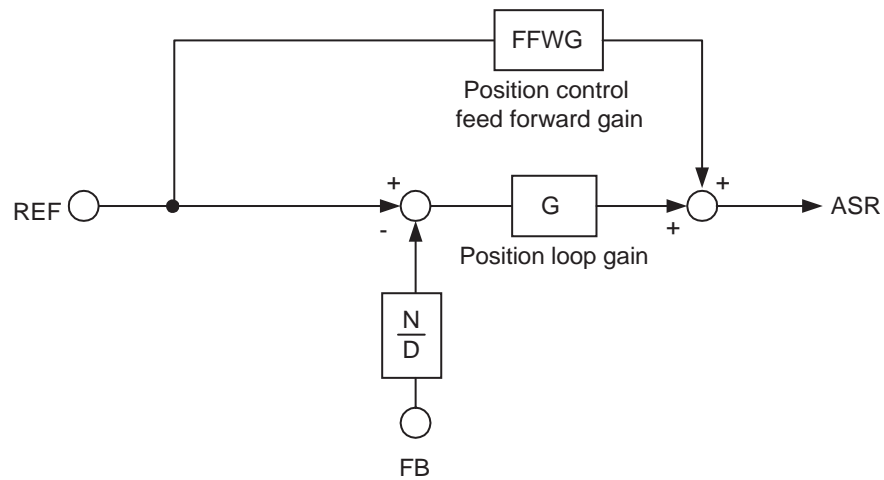

Electronic gear setting position = 00 (FB)

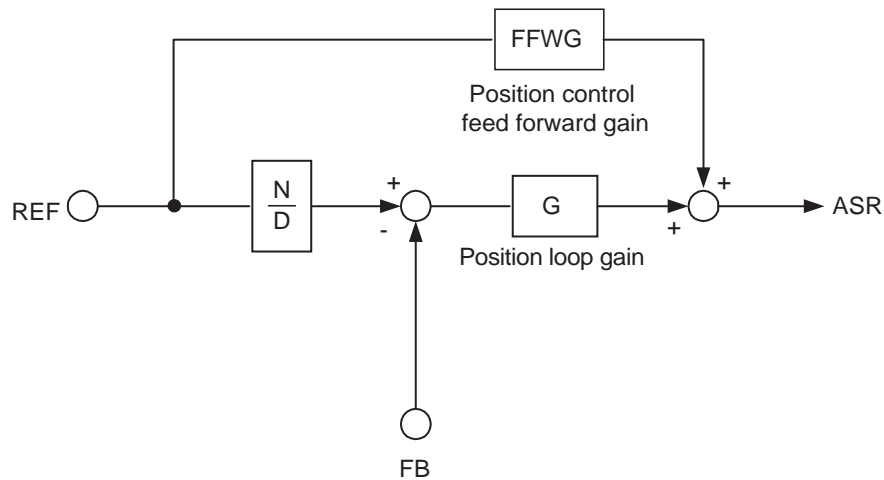

Electronic gear setting position = 01 (REF)

Motor Gear Ratio Setting Function

This function is useful for a system with an optional encoder installed on the machine side.

Set the number of actual encoder pulses in encoder pulses P011.

Set a motor-to-encoder rpm ratio in motor gear ratio numerator/denominator P028/P029.

With the above settings, the number of encoder pulses converted into motor shaft data is set in the Inverter.

This function performs speed/position detection based on the number of encoder pulses converted into motor shaft data, and calculates the orientation stop position based on the number of encoder pulses (P011).

Parameter No.	Function name	Data	Default setting	Unit
P028	Motor gear ratio numerator	0. to 9999 Set a motor-to-encoder rpm ratio.	1.	-
P029	Motor gear ratio denominator			
P011	Encoder pulses	128. to 9999./1000 to 6553 (10000 to 65535) Set the number of actual encoder pulses.	1024.	Pulse

Note: Make sure that the N/D setting is within the range of $1/50 \leq N/D \leq 20$.
(N: Motor gear ratio numerator, D: Motor gear ratio denominator)

<Example>

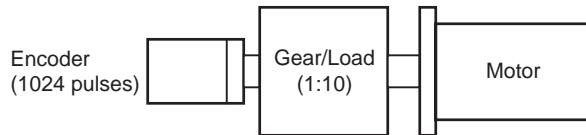

When the motor-to-encoder rpm ratio is 1:10, set the following data.

- Number of encoder pulses (P011) : 1024
- Motor gear ratio numerator (P028) : 10
- Motor gear ratio denominator (P029) : 100

In this case, the orientation stop position is defined as 4096 divisions of the encoder's one rotation. Note that the concept of the stop position is inverted from the description in "Orientation stop position conceptual drawing" (page 4-14).

Position Bias Function

Set this function to apply position command bias in the pulse train position control mode.

The set number of pulses is added to a change value at 2 ms intervals. This is used for adjusting the phase of synchronization points during synchronous operation.

Set an addition value in position bias amount P024. A positive value adds the value in the forward direction.

Related functions	P024
-------------------	------

Speed Bias Function

This function applies speed command bias in the pulse train position control mode.

Set a bias value in frequency addition amount A145, and select a sign in frequency addition direction A146.

Allocate 50 (ADD) to any of the multi-function inputs. While the ADD terminal is turned ON, the bias value is added to the speed command.

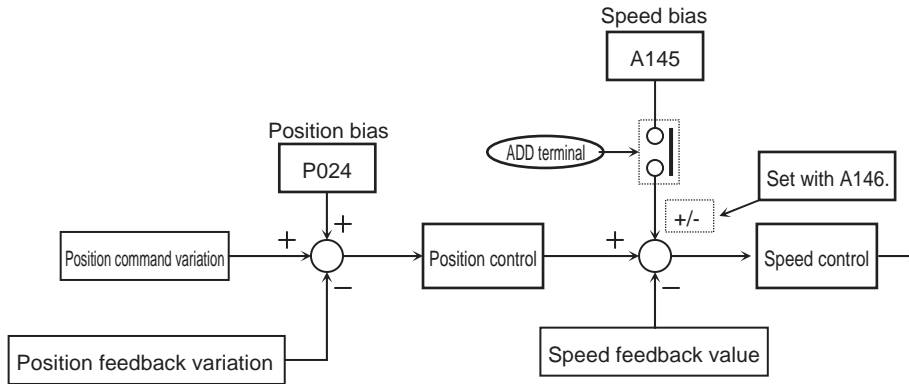

Related functions	A145, A146
-------------------	------------

Orientation Function

This function determines a motor position at a single desired point during one rotation of the motor, and can be used to exchange tools for a machine tool main spindle or others.

During positioning, the Z-pulse (one rotation position signal) is used as the reference signal. Input Z-pulse between EZP and EZN.

Parameter No.	Function name	Data	Default setting	Unit
P011	Encoder pulses	128. to 9999./1000 to 6553 (10000 to 65530)	1024.	Pulse
P014	Orientation stop position	0. to 4095.	0.	-
P015	Orientation speed setting	0.00 to 99.99/100.0 to 120.0	5.00	Hz
P016	Orientation direction setting	00: Forward side	00	
		01: Reverse side		
P017	Position ready range setting	0. to 9999./1000 (10000)	5.	Pulse
P018	Position ready delay time setting	0.00 to 9.99	0.00	s
P023	Position loop gain	0.00 to 99.99/100.0	0.50	rad/s

4-3 Pulse Train Position Control Mode

Parameter No.	Function name	Data	Default setting	Unit
C001 to C008	Multi-function inputs 1 to 8 selection	45: ORT (orientation)	–	–
C021 to C025	Multi-function output terminal selection	23: POK (position ready)	–	
C026	Relay output (MA, MB) function selection		05	

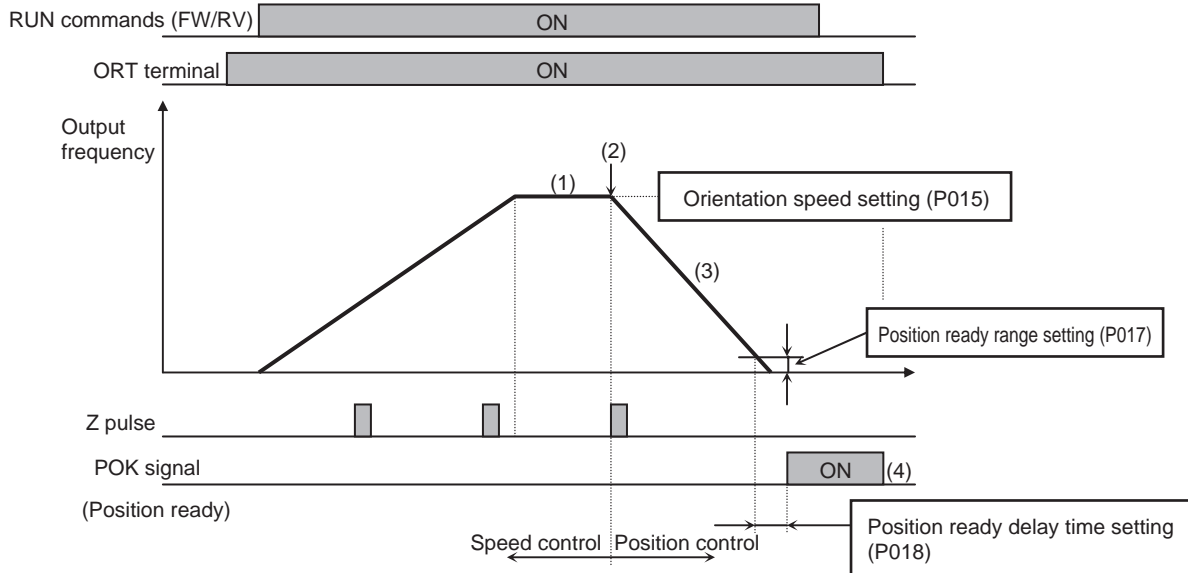

- (1) When the RUN command is turned ON with the ORT terminal turned ON, the Inverter accelerates to the orientation speed (P015), and then performs constant speed operation.
(If the RUN command is input during operation, the operation speed changes to the orientation speed when the ORT terminal is turned ON.)
- (2) After the orientation speed is reached, the Inverter shifts to the position control mode when the first Z-pulse is detected.
- (3) During forward run, position control is performed with a target value of "Orientation stop position (P014) + one rotation"; During reverse run, with a target value of "Orientation stop position (P014) + two rotations".
In this step, the higher the position loop gain (P023), the shorter the deceleration time (regardless of the deceleration time setting).
- (4) After the remaining number of pulses reaches the position ready range setting (P017), the Inverter outputs the POK signal after the position ready delay time setting (P018) elapses. (The POK output remains until the ORT signal is turned OFF.)
After positioning is completed, the servo lock status remains until the RUN command is turned OFF.

Note 1: Do not set a high frequency for the orientation speed, because positioning must be completed within two rotations during deceleration. Otherwise, an overvoltage trip may occur.

Note 2: Orientation stop position is defined as 4096 (0 to 4095) divisions of one forward rotation from the reference point. (The number of divisions is fixed to 4096, regardless of the encoder's number of pulses.)
 The reference point is defined as the point where the pulse is input between EZP and EZN. Below is the layout of the stop target position. (Positive-phase connection)

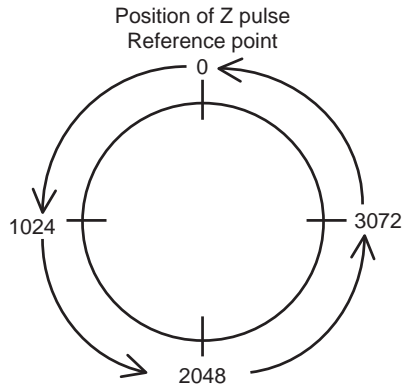

Motor shaft viewed from motor shaft load side

Orientation stop position conceptual drawing

4-4 Absolute Position/High-resolution Absolute Position Control Modes

To use the absolute position control mode, set V/f characteristics selection A044 to "05" (V2), and V2 control mode selection P012 to "02" (APR2: absolute position control).

When "03" (high-resolution absolute position control) is selected in V2 control mode selection P012, control is based on $\times 4$ the number of pulses used for internal operations.
(Set the multi-step position command and position range specification for $\times 4$ multiplication control.)

The position command can be changed up to 8 steps, depending on combinations of multi-function inputs.

Zero return speed can be selected from one low speed and two high speeds.
(The orientation function, described in the previous section, is not available.)

By using the teaching function, you can set the position command while running the machine.
By allocating "73" (SPD) to a multi-function input, you can switch between the speed and position controls.

For data with many digits (e.g. position command), only the higher 4 digits are displayed.

Parameter No.	Function name	Data	Default setting	Unit
P012	V2 control mode selection	02: APR2 (absolute position control mode) 03: HAPR (high-resolution absolute position control mode)	00	—
P023	Position loop gain	0.00 to 99.99/100.0	0.50	rad/s
P060	Multi-step position command 0	Position range specification (reverse side) to Position range specification (forward side)	0	—
P061	Multi-step position command 1	Position range specification (reverse side) to Position range specification (forward side)	0	—
P062	Multi-step position command 2	Position range specification (reverse side) to Position range specification (forward side)	0	—
P063	Multi-step position command 3	Position range specification (reverse side) to Position range specification (forward side)	0	—
P064	Multi-step position command 4	Position range specification (reverse side) to Position range specification (forward side)	0	—
P065	Multi-step position command 5	Position range specification (reverse side) to Position range specification (forward side)	0	—
P066	Multi-step position command 6	Position range specification (reverse side) to Position range specification (forward side)	0	—
P067	Multi-step position command 7	Position range specification (reverse side) to Position range specification (forward side)	0	—
P068	Zero return mode	00: Low 01: Hi1 02: Hi2	00	—
P069	Zero return direction selection	00: Forward side 01: Reverse side	00	—

4-4 Absolute Position/High-resolution Absolute Position Control Modes

Parameter No.	Function name	Data	Default setting	Unit
P070	Low-speed zero return frequency	0.00 to 10.00	0.00	Hz
P071	High-speed zero return frequency	0.00 to 99.99/100.0 to 400.0	0.00	Hz
P072	Position range specification (forward)	0 to +268435456 : when APR2 is selected 0 to +1073741823 : when HAPR is selected	268435455	–
P073	Position range specification (reverse)	–268435456 to 0 : when APR2 is selected –1073741823 to 0 : when HAPR is selected	–268435455	–
P074	Teaching selection	00: Multi-step position command 0 (P060) 01: Multi-step position command 1 (P061) 02: Multi-step position command 2 (P062) 03: Multi-step position command 3 (P063) 04: Multi-step position command 4 (P064) 05: Multi-step position command 5 (P065) 06: Multi-step position command 6 (P066) 07: Multi-step position command 7 (P067)	00	–
C169	Multi-step speed/position determination time	0. to 200. (× 10 ms)	0	ms
d029	Position command monitor	–1073741823 to +1073741823	–	–
d030	Current position monitor	–1073741823 to +1073741823	–	–
C001 to C008	Multi-function inputs 1 to 8 selection	45: ORT (orientation) 54: SON (servo ON) 66: CP1 (position command selection 1) 67: CP2 (position command selection 2) 68: CP3 (position command selection 3) 69: ORL (zero return limit signal) 70: ORG (zero return startup signal) 71: FOT (forward driving stop) 72: ROT (reverse driving stop) 73: SPD (speed/position switching)	–	–
C102	Reset selection	03: Does not initialize internal data during reset.	0	–

Absolute Position Control Operation

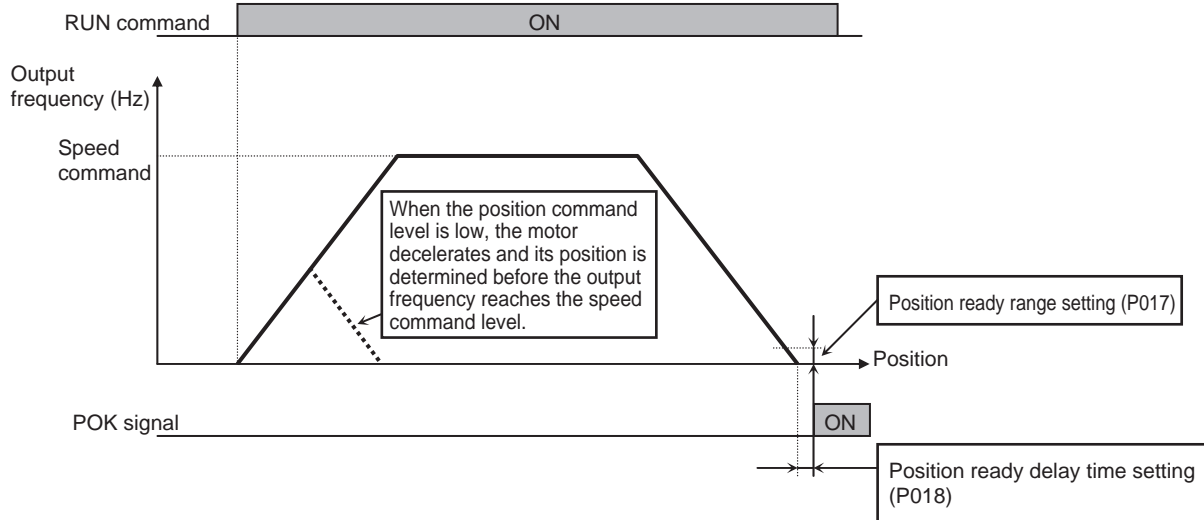

In the absolute position control mode, the Inverter moves to the target position according to the following parameter settings, and is then set in the position servo lock status.

- Position command
- Speed command (frequency reference)
- Acceleration/Deceleration time

(The servo lock status is retained until the RUN command is turned OFF.)

The frequency reference and acceleration/deceleration command for absolute position control conform to the parameters selected when the RUN command is ON.

If the position command is set to a low value, the Inverter may start deceleration and perform positioning before the speed command value is reached.

In the absolute position control mode, the direction of RUN command (FW or RV) does not refer to the rotating direction. The FW or RV signal starts or stops the Inverter. The Inverter runs forward when (Target position – Current position) is a positive value, or runs in reverse when it is a negative value.

If you do not perform zero return operation, the position at power-on is regarded as the origin (position = 0).

When position command is set to zero, position ready is set when the RUN command is turned ON. In reset selection C102, select "03" (trip reset only).

- * If reset selection C102 is not set to "03", turning ON the Inverter's reset terminal (or RESET key) clears the current position counter. To operate the Inverter by using the current position counter value after resetting a trip by turning on the reset terminal (or RESET key), be sure to set reset selection C102 to "03".

If PCLR is allocated, turning on the PCLR terminal clears the current position counter.

(The internal position deviation counter will be simultaneously cleared.)

The absolute position control mode disables the ATR terminal. (Torque control is disabled.)

The absolute position control mode disables the STAT terminal. (Pulse train position control is disabled.)

The absolute position control mode disables the orientation function.

(However, the ORT terminal is used for teaching, as described later.)

Multi-step Position Switching Function (CP1/CP2/CP3)

By allocating “66” to “68” (CP1 to CP3) to any of multi-function inputs 1 to 8 (C001 to C008), you can select from multi-step positions 0 to 7.

Set position commands in multi-step position commands 0 to 7 (P060 to P067).

If no position command is allocated to the terminals, multi-step position command 0 (P060) is defined as the position command.

Position command	CP3	CP2	CP1
Multi-step position 0	0	0	0
Multi-step position 1	0	0	1
Multi-step position 2	0	1	0
Multi-step position 3	0	1	1
Multi-step position 4	1	0	0
Multi-step position 5	1	0	1
Multi-step position 6	1	1	0
Multi-step position 7	1	1	1

When you input a multi-step position command, you can set the wait time until the terminal input is determined. This prevents the transition status from being applied before it is determined.

You can adjust the determination time in multi-step speed/position determination time C169. If no input is made during the time set in C169, the data is determined after the set time elapses. (Note that the longer the determination time, the slower the input response.)

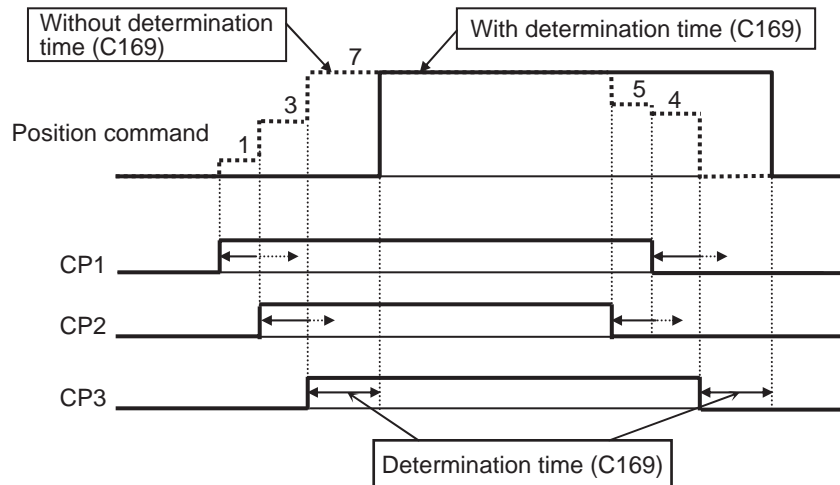

Speed/Position Switching Function (SPD)

This function is used for speed control operation.

Allocate “73” (SPD) to any of the multi-function inputs.

While the SPD terminal is turned ON, the current position counter is retained at zero. The Inverter shifts to the position control mode when the SPD terminal is turned OFF during operation. (Speed/Position switching)

With the position command set to 0, the Inverter shifts to the stop operation when the SPD terminal is turned OFF

(Hunting may occur, depending on the position loop gain setting.)

While the SPD terminal is turned ON, the Inverter runs in the direction specified by the RUN command. To shift from speed control to position control, be careful about the polarity sign of the RUN command.

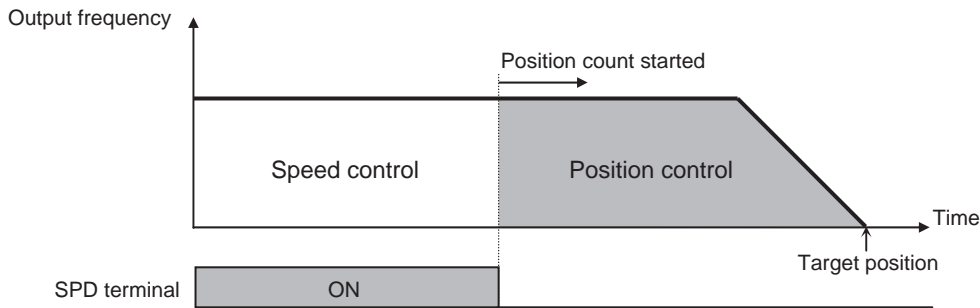

Zero Return Function

This function performs three types of zero return operations according to the zero return mode P068. When zero return is complete, the current position is cleared to zero.

You can select the zero return direction in zero return direction selection P069.

If zero return is not performed, the Inverter performs position control with the position at power-on defined as the origin.

<Low-speed zero return (P068 = 00)>

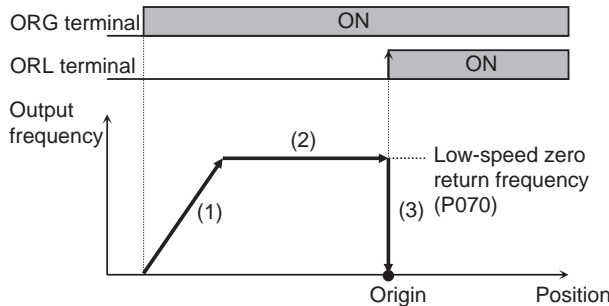

- (1) The Inverter accelerates to the low-speed zero return frequency according to the acceleration time setting.
- (2) The Inverter runs at the low-speed zero return frequency.
- (3) The Inverter performs positioning when the ORL signal is input.

<High-speed zero return 1 (P068 = 01)>

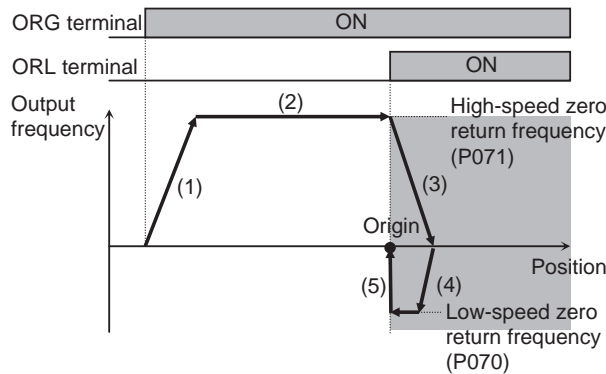

- (1) The Inverter accelerates to the high-speed zero return frequency according to the acceleration time setting.
- (2) The Inverter runs at the high-speed zero return frequency.
- (3) The Inverter starts deceleration when the ORL signal is turned ON.
- (4) The Inverter runs in reverse at the low-speed zero return frequency.
- (5) The Inverter performs positioning when the ORL signal is turned OFF.

<High-speed zero return 2 (P068 = 02)>

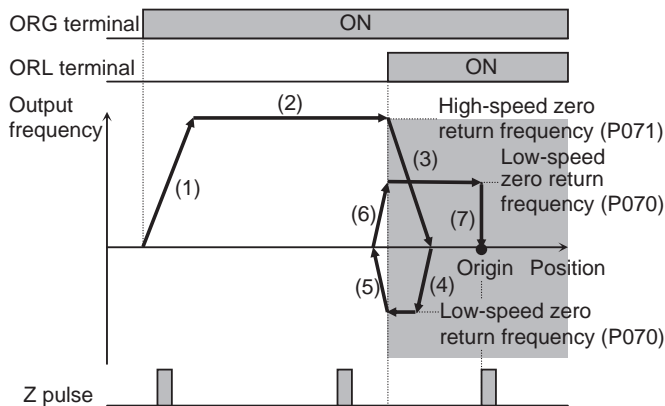

- (1) The Inverter accelerates to the high-speed zero return frequency according to the acceleration time setting.
- (2) The Inverter runs at the high-speed zero return frequency.
- (3) The Inverter starts deceleration when the ORL signal is turned ON.
- (4) The Inverter runs in reverse at the low-speed zero return frequency.
- (5) The Inverter starts deceleration when the ORL signal is turned OFF.
- (6) The Inverter runs forward at the low-speed zero return frequency.
- (7) The Inverter performs positioning at the first Z-pulse position after the ORL signal is turned ON.

Forward/Reverse Run Stop Function (FOT/ROT)

With a signal from the control range limit switch, this function prevents the Inverter from running outside the specified operation range.

The torque limit is set to 10% on the forward side when the FOT terminal is turned on, and on the reverse side when the ROT terminal is turned on.

This function can be used as the limit switch at the machine end, when “71” (FOT) and “72” (ROT) are allocated to any of multi-function inputs 1 to 8 (C001 to C008).

Position Range Specification Function

Set a forward/reverse position control range in position range specification (forward) P072 and position range specification (reverse) P073. If the current position counter exceeds this setting range, the position control range trip (E63.* or E73.*) occurs, and the Inverter goes into free-run status.

The upper limit setting of multi-step position commands 0 to 7 is limited by this position range setting.

(You cannot set a position command beyond the position range.)

Teaching Function

This function starts or stops the motor at a desired position and stores the current position in a desired position command area.

Allocate “45” (ORT) to any of multi-function inputs 1 to 8 (C001 to C008).

When V2 control mode selection P012 is set to “02” (absolute position control) or “03” (high-resolution absolute position control), the relevant terminal serves as a teaching terminal.

Related functions	C001 to C008, C012, C074
-------------------	--------------------------

<Teaching Procedure>

(1) In teaching selection P074, select the position command you want to set.

(2) Move the workpiece.

- Input the RUN command with the ORT terminal turned ON. At this time, the speed command and acceleration/deceleration time conform to the currently selected parameters.

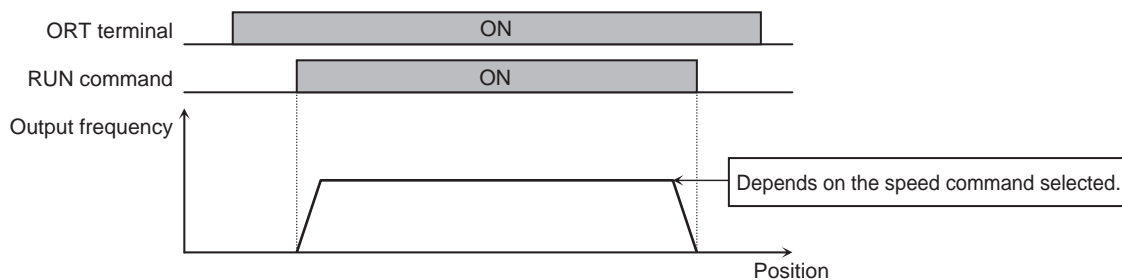

* If the Inverter control circuit (Ro, To) is turned on, teaching is enabled.
The current position counter operates even if the workpiece is moved by an external device.
Teaching is therefore enabled even while the Inverter is stopped.

Note: Make sure that the Inverter power circuit (R/L1, S/L2, T/L3) is turned off. Also, make sure that the Inverter’s output (U/T1, V/T2, W/T3) is disconnected from the motor. Not doing so may result in injury and/or damage to the equipment.

- (3) When the target position is reached, press the Enter key on the Digital Operator. Press the key on the data display screen (the PRG LED indicator is lit).
- (4) The current position is set to the area corresponding to the position command source set in teaching selection P074.
(However, the P074 setting is not stored. After the power is shut off or after reset, this parameter is indicated as "00" (x00).)

P074 set values	Position commands to be set
00	P060: Multi-step position command 0
01	P061: Multi-step position command 1
02	P062: Multi-step position command 2
03	P063: Multi-step position command 3
04	P064: Multi-step position command 4
05	P065: Multi-step position command 5
06	P066: Multi-step position command 6
07	P067: Multi-step position command 7

Servo ON Function

This function brings the Inverter into speed servo lock status via an input terminal when "05" (sensor vector control) is selected in V/f characteristics selection A044.

Allocate 54 (SON) to the desired multi-function input.

The Inverter will not accept the RUN command unless the SON terminal is turned on when SON is allocated.

If the SON terminal is turned off during operation, the Inverter goes into free-run status. When the SON terminal is turned on again, the Inverter restarts according to the setting of free-run stop selection b088.

This function cannot be simultaneously used with the preliminary excitation function (55: FOC). If FOC and SON are both allocated to multi-function inputs, priority is given to FOC, and SON is disabled.

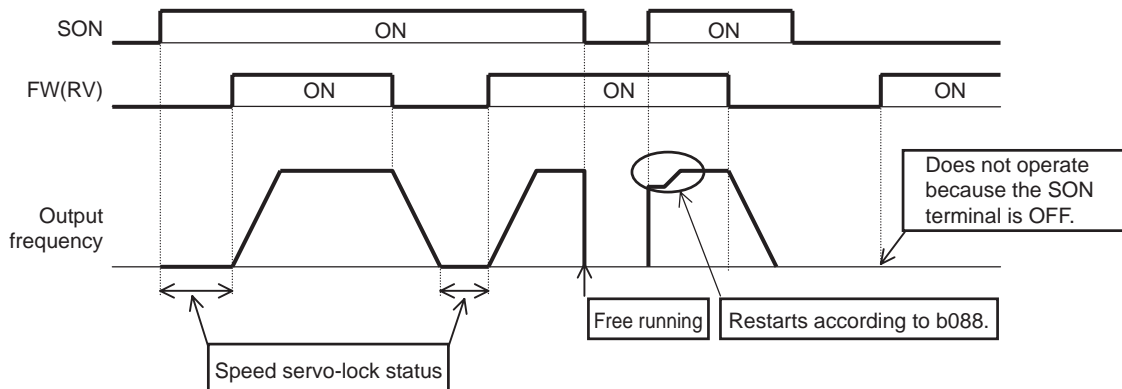

Related functions	A044, C001 to C008
-------------------	--------------------

Pulse Train Frequency Input

This function allows you to use a pulse train input to the SAP-SAN terminals on the PG Board as frequency reference or PID feedback value in each control mode.

(This function can be used in all control modes.)

Set the input frequency at the maximum frequency in pulse train frequency scale P055. The analog input start/end function cannot be used. To limit the input frequency, use pulse train frequency bias amount P057 and pulse train frequency limit P058.

4
Functions

Parameter No.	Function name	Data	Default setting	Unit
P055	Pulse train frequency scale	1.0 to 50.0: Set the input frequency at the maximum frequency.	25.0	kHz
P056	Pulse train frequency filter time constant	0.01 to 2.00: Set a filter time constant for pulse train input.	0.10	s
P057	Pulse train frequency bias amount	-100. to +100.	0.	%
P058	Pulse train frequency limit	0. to 100.	100.	%
A001	Frequency reference selection	06: Pulse train frequency	02	-
A076	PID feedback selection	03: Pulse train frequency	00	
A141	Operation frequency input A setting	07: Pulse train frequency	02	
A142	Operation frequency input B setting	07: Pulse train frequency	03	

Pulse train frequency processing block

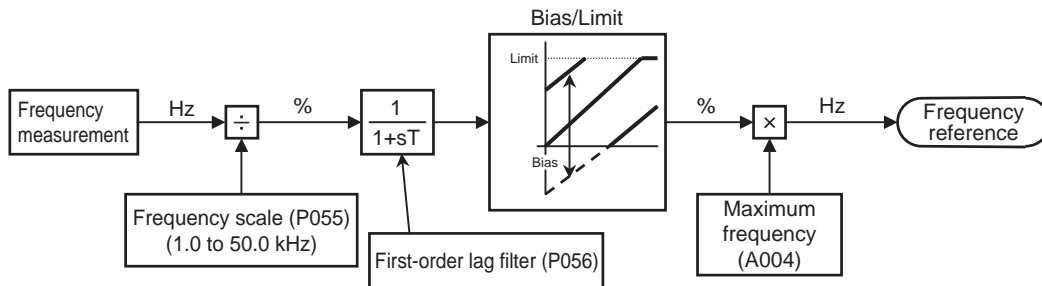

Note: Set the SWENC switch on the PG Board to “OFF: encoder disconnection detection disabled”.

Chapter 5

Maintenance Operations

5-1	Operation Selection During Option Error	5-1
5-2	Cause and Countermeasure of Option Errors...	5-2
5-3	Warning Display	5-3

5-1 Operation Selection During Option Error

You can select whether to trip the Inverter or continue operation ignoring an error when the optional PG Board causes an error.

Parameter No.	Function name	Data	Default setting	Changes during operation	Unit
P001	Operation selection at option 1 error	00: Trip 01: Continues operation	00	×	—
P002	Operation selection at option 2 error	00: Trip 01: Continues operation	00	×	—

Note: Even if 01 has been selected in operation selection at option error, the Inverter trips when an encoder disconnection error (E60, E70) or 3G3AX-PG connection error (E69, E79) occurs. Refer to "2-6 Switch Settings"(page 2-8).

5-2 Cause and Countermeasure of Option Errors

The Inverter stops and displays an error in the following cases.

Fault display	Function name	Description	Remedy
E60 ^{*1} E70 ^{*1}	Encoder disconnection	Detects encoder disconnection and connection failure.	Check the connection and conductive wire of encoder line.
		Detects if the encoder has broken or the encoder is not the one that specifies the line driver output.	Use the specified encoder instead.
		Detects if an encoder without phase Z has been used	Turn OFF the SWENC-2 on the PG Board.
E61 ^{*1} E71 ^{*1}	Overspeed	Detects if the motor rotation has exceeded (Maximum frequency ^{*2})×(Overspeed error detection level [P026]). ^{*3}	Adjust the parameters of Kp and J relating to the speed control and reduce overshooting.
E62 ^{*1} E72 ^{*1}	Positioning error	Detects if the current position deviation against the position command value exceeds 1,000,000 pulses during position control.	Set the larger value for position loop gain of position control. Reduce the pulse per unit time of the pulse train position command input.
E63 ^{*1} E73 ^{*1}	Position control range trip	Shuts off the output and displays an error when the current position exceeds the set values for the positioning range specifications for both Forward (P072) and Reverse (P073) during absolute position control.	Correct the position command.
E69 ^{*1} E79 ^{*1}	3G3AX-PG connection error	Detects PG Board connection failure.	Check the PG Board connection.

*1 Appears when the PG Board is connected to Board port 2.

*2 Upper limit value is applied when the frequency upper limit (A061) is set.

*3 This error could occur again even if the trip is reset during free running. Reset the trip after stopping motor operation.

5-3 Warning Display

For warnings other than the one mentioned below, refer to the general-purpose Inverter 3G3RX User's Manual.

Fault display	Description
H 0 0 9	Displays when the orientation speed setting (P015) becomes larger than the maximum frequency (A004). Check the orientation speed setting and the maximum frequency.

Chapter 6

Specifications

6-1	Product Specifications	6-1
-----	------------------------------	-----

6-1 Product Specifications

Item		Specifications
Speed control	Encoder feedback	<ul style="list-style-type: none"> Standard number of encoder pulses: 1024 pulses/r Maximum input number of pulses: 100k pulses/s
	Speed control system	<ul style="list-style-type: none"> Proportional integral (PI)/ Proportional (P) control
Position control	Position command	<ul style="list-style-type: none"> The pulse train can be input in three modes. <ul style="list-style-type: none"> Mode 0: Pulse train with 90° phase difference Mode 1: Forward/Reverse command + Pulse train Mode 2: Forward pulse train + Reverse pulse train The input mode depends on the Inverter setting. Maximum input number of pulses: 100k pulses/s
	Electronic gear	<ul style="list-style-type: none"> Pulse ratio A/B (A, B: 1 to 9999 can be set) Available setting range: $1/50 \leq A/B \leq 20$
Orientation	Stop position	<ul style="list-style-type: none"> 4096 divisions per one motor rotation^{*1}
	Speed	<ul style="list-style-type: none"> Orientation speed and rotation direction settings available
Protective functions		<ul style="list-style-type: none"> Encoder cable disconnection protection Overspeed protection (Overspeed error detection level (P026)) Positioning error 3G3AX-PG connection error

*1 The Inverter setting or external input is available. Note that the 3G3AX-DI Board is required separately for the external input.