



SIRIUS Compact load feeder DOL starter 690 V 24 V AC/DC 50...60 Hz 0.32...1.25 A IP20 Connection main circuit: Spring-type terminal Connection auxiliary circuit: Spring-type terminal

product brand name	SIRIUS
product designation	compact starter
design of the product	direct starter
product type designation	3RA61
General technical data	
product function control circuit interface to parallel wiring	Yes
product extension auxiliary switch	Yes
power loss [W] for rated value of the current	
• at AC in hot operating state	0.1 W
• at AC in hot operating state per pole	0.03 W
• without load current share typical	2.9 W
insulation voltage rated value	690 V
degree of pollution	3
surge voltage resistance rated value	6 000 V
maximum permissible voltage for safe isolation	
• between main and auxiliary circuit	400 V
• between auxiliary and auxiliary circuit	250 V
• between control and auxiliary circuit	300 V
degree of protection NEMA rating	other
shock resistance	a=60 m/s ² (6g) with 10 ms per 3 shocks in all axes
vibration resistance	f= 4 ... 5.8 Hz, d= 15 mm; f= 5.8 ... 500 Hz, a= 20 m/s ² ; 10 cycles
mechanical service life (operating cycles)	
• of the main contacts typical	10 000 000
• of auxiliary contacts typical	10 000 000
• of the signaling contacts typical	10 000 000
electrical endurance (operating cycles) of auxiliary contacts	
• at DC-13 at 6 A at 24 V typical	30 000
• at AC-15 at 6 A at 230 V typical	200 000
type of assignment	continuous operation according to IEC 60947-6-2
reference code according to IEC 81346-2	Q
Substance Prohibitance (Date)	05/01/2012
Ambient conditions	
installation altitude at height above sea level maximum	2 000 m
ambient temperature	
• during operation	-20 ... +60 °C
• during storage	-55 ... +80 °C
• during transport	-55 ... +80 °C
relative humidity during operation	10 ... 90 %
Main circuit	
number of poles for main current circuit	3

adjustable current response value current of the current-dependent overload release	0.32 ... 1.25 A
formula for making capacity limit current	38.4 x I _e
formula for limit current breaking capacity	32 x I _e
yielded mechanical performance for 4-pole AC motor	
• at 400 V rated value	0.37 kW
• at 500 V rated value	0.55 kW
• at 690 V rated value	0.75 kW
operating voltage at AC-3 rated value maximum	690 V
operational current	
• at AC at 400 V rated value	1.25 A
• at AC-3 at 400 V rated value	1.25 A
• at AC-43	
— at 400 V rated value	1.1 A
— at 500 V rated value	1.2 A
— at 690 V rated value	1.1 A
operating power	
• at AC-3 at 400 V rated value	0.37 kW
• at AC-43	
— at 400 V rated value	370 W
— at 500 V rated value	550 W
— at 690 V rated value	750 W
no-load switching frequency	3 600 1/h
operating frequency	
• at AC-41 according to IEC 60947-6-2 maximum	750 1/h
• at AC-43 according to IEC 60947-6-2 maximum	250 1/h
Control circuit/ Control	
type of voltage	AC/DC
control supply voltage 1 at AC	
• at 50 Hz rated value	24 V
• at 50 Hz	24 ... 24 V
• at 60 Hz rated value	24 V
• at 60 Hz	24 V
control supply voltage frequency	
• 1 rated value	50 Hz
• 2 rated value	60 Hz
control supply voltage 1	
• at DC rated value	24 V
• at DC	24 ... 24 V
holding power	
• at AC maximum	2.8 W
• at DC maximum	2.9 W
Auxiliary circuit	
number of NC contacts for auxiliary contacts	1
number of NO contacts for auxiliary contacts	1
number of NO contacts of instantaneous short-circuit trip unit for signaling contact	1
number of CO contacts of the current-dependent overload release for signaling contact	1
operational current of auxiliary contacts at AC-12 maximum	10 A
operational current of auxiliary contacts at DC-13 at 250 V	0.27 A
Protective and monitoring functions	
trip class	CLASS 10 and 20 adjustable
operating short-circuit current breaking capacity (I_{cs})	
• at 400 V	53 kA
• at 500 V rated value	3 kA
• at 690 V rated value	3 kA
UL/CSA ratings	
full-load current (FLA) for 3-phase AC motor	
• at 480 V rated value	1.25 A
• at 600 V rated value	1.25 A

yielded mechanical performance [hp] for 3-phase AC motor	
<ul style="list-style-type: none"> at 460/480 V rated value at 575/600 V rated value 	0.5 hp 0.5 hp
contact rating of auxiliary contacts according to UL	contacts 21-22, 13-14, 43-44 Q600 / A600, contacts 77-78 R300 / B300, contacts 95-96-98 R300 / D300
Short-circuit protection	
product function short circuit protection	Yes
design of short-circuit protection	electromagnetic
design of the fuse link	
<ul style="list-style-type: none"> for short-circuit protection of the auxiliary switch required for short-circuit protection of the signaling switch of the short-circuit release required for short-circuit protection of the signaling switch of the overload release required 	fuse gL/gG: 10 A 6A gL/gG/400V 4A gL/gG/400V
Installation/ mounting/ dimensions	
mounting position	any
<ul style="list-style-type: none"> recommended 	vertical, on horizontal standard DIN rail
fastening method	screw and snap-on mounting
height	191 mm
width	45 mm
depth	165 mm
Connections/ Terminals	
product component removable terminal for main circuit	Yes
product component removable terminal for auxiliary and control circuit	Yes
type of electrical connection	
<ul style="list-style-type: none"> for main current circuit for auxiliary and control circuit 	spring-loaded terminals spring-loaded terminals
type of connectable conductor cross-sections for main contacts	
<ul style="list-style-type: none"> solid finely stranded with core end processing finely stranded without core end processing 	2x (1.5 ... 6 mm ²), 1x 10 mm ² 2x (1.5 ... 6 mm ²) 2x (1.5 ... 6 mm ²)
type of connectable conductor cross-sections	
<ul style="list-style-type: none"> for auxiliary contacts <ul style="list-style-type: none"> — solid — finely stranded with core end processing — finely stranded without core end processing at AWG cables for auxiliary contacts 	2x (0.25 ... 1.5 mm ²) 2x (0.25 ... 1.5 mm ²) 2x (0.25 ... 1.5 mm ²) 2x (24 ... 16)
Safety related data	
B10 value with high demand rate according to SN 31920	3 000 000
proportion of dangerous failures	
<ul style="list-style-type: none"> with low demand rate according to SN 31920 with high demand rate according to SN 31920 	40 % 50 %
failure rate [FIT] with low demand rate according to SN 31920	100 FIT
T1 value for proof test interval or service life according to IEC 61508	20 a
protection class IP on the front according to IEC 60529	IP20
touch protection on the front according to IEC 60529	finger-safe
Communication/ Protocol	
product function bus communication	No
protocol is supported	
<ul style="list-style-type: none"> AS-Interface protocol IO-Link protocol 	No No
product function control circuit interface with IO link	No
Electromagnetic compatibility	
conducted interference	
<ul style="list-style-type: none"> due to burst according to IEC 61000-4-4 due to conductor-earth surge according to IEC 61000-4-5 due to conductor-conductor surge according to IEC 61000-4-5 due to high-frequency radiation according to IEC 61000-4-6 	4 kV main contacts, 2 kV auxiliary contacts 4 kV main contacts, 2 kV auxiliary contacts 2 kV main contacts, 1 kV auxiliary contacts 0.15-80Mhz at 10V

field-based interference according to IEC 61000-4-3	10 V/m
electrostatic discharge according to IEC 61000-4-2	8 kV
conducted HF interference emissions according to CISPR11	150 kHz ... 30 MHz Class A
field-bound HF interference emission according to CISPR11	30 ... 1000 MHz Class A
Supply voltage	
Supply voltage required Auxiliary voltage	No
Display	
number of LEDs	2
Certificates/ approvals	
General Product Approval	EMC



[Confirmation](#)



Functional Safety/Safety of Machinery	Declaration of Conformity	Test Certificates	Marine / Shipping
---------------------------------------	---------------------------	-------------------	-------------------



EG-Konf.

[Type Test Certificates/Test Report](#)



Marine / Shipping	other	Dangerous Good
-------------------	-------	----------------



[Confirmation](#)

[Transport Information](#)

Further information

Siemens has decided to exit the Russian market (see here).

<https://press.siemens.com/global/en/pressrelease/siemens-wind-down-russian-business>

Siemens is working on the renewal of the current EAC certificates.

Please contact your local Siemens office on the status of validity of the EAC certification if you intend to import or offer to supply these products to an EAC relevant market (other than the sanctioned EAEU member states Russia or Belarus).

Information on the packaging

<https://support.industry.siemens.com/cs/ww/en/view/109813875>

Information- and Downloadcenter (Catalogs, Brochures,...)

<https://www.siemens.com/ic10>

Industry Mall (Online ordering system)

<https://mall.industry.siemens.com/mall/en/en/Catalog/product?mlfb=3RA6120-2BB32>

Cax online generator

<http://support.automation.siemens.com/WW/CAXorder/default.aspx?lang=en&mlfb=3RA6120-2BB32>

Service&Support (Manuals, Certificates, Characteristics, FAQs,...)

<https://support.industry.siemens.com/cs/ww/en/ps/3RA6120-2BB32>

Image database (product images, 2D dimension drawings, 3D models, device circuit diagrams, EPLAN macros, ...)

http://www.automation.siemens.com/bilddb/cax_de.aspx?mlfb=3RA6120-2BB32&lang=en

Characteristic: Tripping characteristics, I²t, Let-through current

<https://support.industry.siemens.com/cs/ww/en/ps/3RA6120-2BB32/char>

Further characteristics (e.g. electrical endurance, switching frequency)

<http://www.automation.siemens.com/bilddb/index.aspx?view=Search&mlfb=3RA6120-2BB32&objecttype=14&gridview=view1>

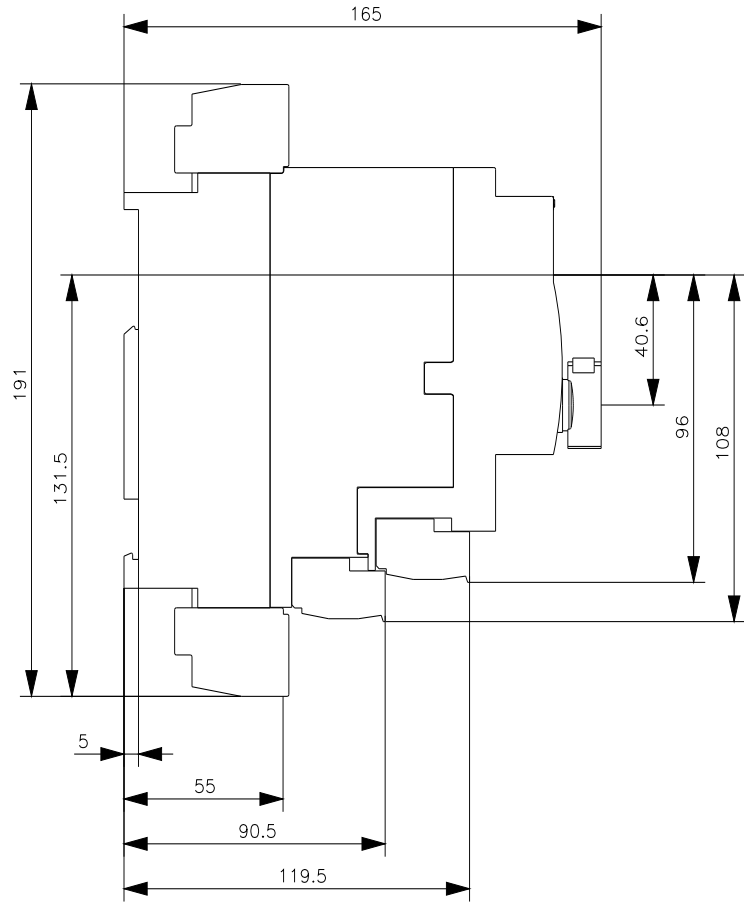
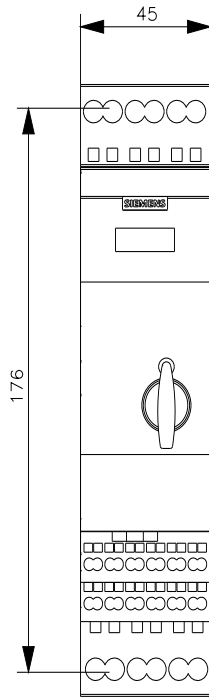

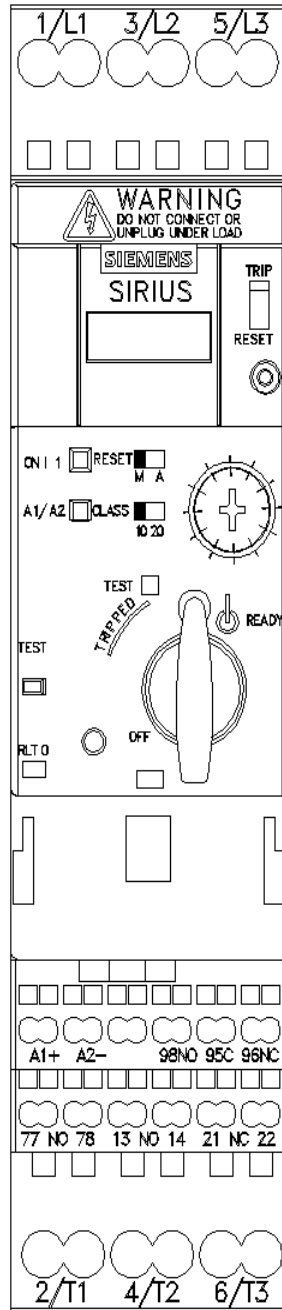

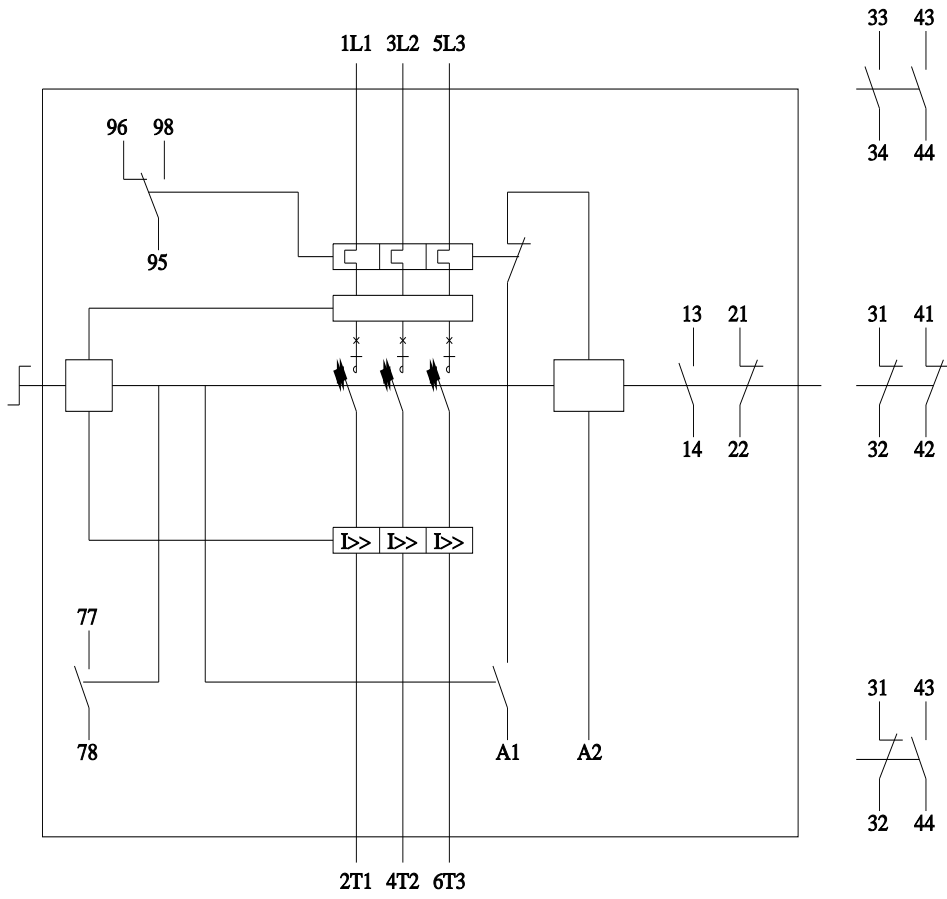

last modified:

11/21/2022 