



traction contactor, AC-3e/AC-3, 12 A, 5.5 kW / 400 V, 110 V DC 0.7-1.25*
Us, with varistor integrated, 3-pole frame size S00, spring-loaded terminal
upright mounting position

product brand name	SIRIUS
product designation	Power contactor
design of the product	With extended operating range
product type designation	3RT2
General technical data	
size of contactor	S00
product extension	
• function module for communication	No
• auxiliary switch	Yes
power loss [W] for rated value of the current	
• at AC in hot operating state	3.6 W
• at AC in hot operating state per pole	1.2 W
• without load current share typical	4 W
insulation voltage	
• of main circuit with degree of pollution 3 rated value	690 V
• of auxiliary circuit with degree of pollution 3 rated value	690 V
surge voltage resistance	
• of main circuit rated value	6 kV
• of auxiliary circuit rated value	6 kV
maximum permissible voltage for safe isolation between coil and main contacts according to EN 60947-1	400 V
shock resistance at rectangular impulse	
• at DC	7.3g / 5 ms, 4.7g / 10 ms
shock resistance with sine pulse	
• at DC	11,4g / 5 ms, 7,3g / 10 ms
mechanical service life (switching cycles)	
• of contactor typical	30 000 000
• of the contactor with added electronically optimized auxiliary switch block typical	5 000 000
• of the contactor with added auxiliary switch block typical	10 000 000
reference code according to IEC 81346-2	Q
Substance Prohibition (Date)	10/01/2009
Ambient conditions	
installation altitude at height above sea level maximum	2 000 m
ambient temperature	
• during operation	-40 ... +70 °C
• during storage	-55 ... +80 °C
relative humidity minimum	10 %
relative humidity at 55 °C according to IEC 60068-2-30 maximum	95 %

Main circuit

number of poles for main current circuit	3
number of NO contacts for main contacts	3
operating voltage	
• at AC-3 rated value maximum	690 V
• at AC-3e rated value maximum	690 V
operational current	
• at AC-1 at 400 V at ambient temperature 40 °C rated value	22 A
• at AC-1	
— up to 690 V at ambient temperature 40 °C rated value	22 A
— up to 690 V at ambient temperature 60 °C rated value	20 A
• at AC-2 at 400 V rated value	12 A
• at AC-3	
— at 400 V rated value	12 A
— at 500 V rated value	9.2 A
— at 690 V rated value	6.7 A
• at AC-3e	
— at 400 V rated value	12 A
— at 500 V rated value	9.2 A
— at 690 V rated value	6.7 A
• at AC-4 at 400 V rated value	8.5 A
minimum cross-section in main circuit	
• at maximum AC-1 rated value	4 mm ²
operational current for approx. 200000 operating cycles at AC-4	
• at 400 V rated value	4.1 A
• at 690 V rated value	3.3 A
operating power	
• at AC-2 at 400 V rated value	5.5 kW
• at AC-3	
— at 230 V rated value	3 kW
— at 400 V rated value	5.5 kW
— at 500 V rated value	5.5 kW
— at 690 V rated value	5.5 kW
• at AC-3e	
— at 230 V rated value	3 kW
— at 400 V rated value	5.5 kW
— at 500 V rated value	5.5 kW
— at 690 V rated value	5.5 kW
operating power for approx. 200000 operating cycles at AC-4	
• at 400 V rated value	2 kW
• at 690 V rated value	2.5 kW
short-time withstand current in cold operating state up to 40 °C	
• limited to 1 s switching at zero current maximum	200 A; Use minimum cross-section acc. to AC-1 rated value
• limited to 5 s switching at zero current maximum	123 A; Use minimum cross-section acc. to AC-1 rated value
• limited to 10 s switching at zero current maximum	96 A; Use minimum cross-section acc. to AC-1 rated value
• limited to 30 s switching at zero current maximum	74 A; Use minimum cross-section acc. to AC-1 rated value
• limited to 60 s switching at zero current maximum	61 A; Use minimum cross-section acc. to AC-1 rated value
no-load switching frequency	
• at DC	1 500 1/h
operating frequency	
• at AC-2 at AC-3e maximum	750 1/h
• at AC-4 maximum	250 1/h

Control circuit/ Control

type of voltage	DC
type of voltage of the control supply voltage	DC
control supply voltage at DC	
• rated value	110 V
operating range factor control supply voltage rated value of magnet coil at DC	

<ul style="list-style-type: none"> • initial value • full-scale value 	0.7 1.25
design of the surge suppressor	with varistor
closing power of magnet coil at DC	13 W
holding power of magnet coil at DC	4 W
closing delay	
<ul style="list-style-type: none"> • at DC 	25 ... 130 ms
opening delay	
<ul style="list-style-type: none"> • at DC 	7 ... 20 ms
arcing time	10 ... 15 ms
control version of the switch operating mechanism	E1 - A2
Auxiliary circuit	
number of NC contacts for auxiliary contacts	1
operational current at AC-12 maximum	10 A
operational current at AC-15	
<ul style="list-style-type: none"> • at 230 V rated value • at 400 V rated value • at 500 V rated value • at 690 V rated value 	10 A 3 A 2 A 1 A
operational current at DC-12	
<ul style="list-style-type: none"> • at 24 V rated value • at 48 V rated value • at 60 V rated value • at 110 V rated value • at 125 V rated value • at 220 V rated value • at 600 V rated value 	10 A 6 A 6 A 3 A 2 A 1 A 0.15 A
operational current at DC-13	
<ul style="list-style-type: none"> • at 24 V rated value • at 48 V rated value • at 60 V rated value • at 110 V rated value • at 125 V rated value • at 220 V rated value • at 600 V rated value 	10 A 2 A 2 A 1 A 0.9 A 0.3 A 0.1 A
UL/CSA ratings	
full-load current (FLA) for 3-phase AC motor	
<ul style="list-style-type: none"> • at 480 V rated value • at 600 V rated value 	11 A 11 A
yielded mechanical performance [hp]	
<ul style="list-style-type: none"> • for single-phase AC motor <ul style="list-style-type: none"> — at 110/120 V rated value — at 230 V rated value • for 3-phase AC motor <ul style="list-style-type: none"> — at 200/208 V rated value — at 220/230 V rated value — at 460/480 V rated value — at 575/600 V rated value 	0.5 hp 2 hp 3 hp 3 hp 7.5 hp 10 hp
contact rating of auxiliary contacts according to UL	A600 / Q600
Short-circuit protection	
product function short circuit protection	No
design of the fuse link	
<ul style="list-style-type: none"> • for short-circuit protection of the main circuit <ul style="list-style-type: none"> — with type of coordination 1 required — with type of assignment 2 required • for short-circuit protection of the auxiliary switch required 	gG: 50A (690V,100kA), aM: 20A (690V,100kA), BS88: 35A (415V,80kA) gG: 20A (690V,100kA), aM: 16A (690V, 100kA), BS88: 20A (415V, 80kA) gG: 10 A (500 V, 1 kA)
Installation/ mounting/ dimensions	
mounting position	standing, on horizontal mounting surface
fastening method	screw and snap-on mounting onto 35 mm DIN rail according to DIN EN 60715
<ul style="list-style-type: none"> • side-by-side mounting 	Yes

height	70 mm
width	45 mm
depth	121 mm
required spacing	
• with side-by-side mounting	
— forwards	10 mm
— upwards	10 mm
— downwards	10 mm
— at the side	0 mm
• for grounded parts	
— forwards	10 mm
— upwards	10 mm
— at the side	6 mm
— downwards	10 mm
• for live parts	
— forwards	10 mm
— upwards	10 mm
— downwards	10 mm
— at the side	6 mm

Connections/ Terminals

type of electrical connection	
• for main current circuit	spring-loaded terminals
• for auxiliary and control circuit	spring-loaded terminals
• at contactor for auxiliary contacts	Spring-type terminals
• of magnet coil	Spring-type terminals
type of connectable conductor cross-sections	
• for main contacts	
— solid	2x (0.5 ... 1.5 mm ²), 2x (0.75 ... 2.5 mm ²), 2x 4 mm ²
— solid or stranded	2x (0,5 ... 4 mm ²)
— finely stranded with core end processing	2x (0.5 ... 2.5 mm ²)
— finely stranded without core end processing	2x (0.5 ... 2.5 mm ²)
• at AWG cables for main contacts	2x (20 ... 12)
type of connectable conductor cross-sections	
• for auxiliary contacts	
— solid or stranded	2x (0,5 ... 4 mm ²)
— finely stranded with core end processing	2x (0.5 ... 2.5 mm ²)
— finely stranded without core end processing	2x (0.5 ... 2.5 mm ²)
• at AWG cables for auxiliary contacts	2x (20 ... 12)
AWG number as coded connectable conductor cross section	
• for main contacts	20 ... 12
• for auxiliary contacts	20 ... 12

Safety related data

product function	
• mirror contact according to IEC 60947-4-1	Yes
• positively driven operation according to IEC 60947-5-1	No
B10 value with high demand rate according to SN 31920	1 000 000
proportion of dangerous failures	
• with low demand rate according to SN 31920	40 %
• with high demand rate according to SN 31920	73 %
failure rate [FIT] with low demand rate according to SN 31920	100 FIT
T1 value for proof test interval or service life according to IEC 61508	20 y
protection class IP on the front according to IEC 60529	IP20
touch protection on the front according to IEC 60529	finger-safe, for vertical contact from the front

Communication/ Protocol

product function bus communication	No
---	----

Certificates/ approvals

General Product Approval	
---------------------------------	--



[Confirmation](#)



[KC](#)



EMC	Functional Safety/Safety of Machinery	Declaration of Conformity	Test Certificates
-----	---------------------------------------	---------------------------	-------------------



[Type Examination Certificate](#)



[Type Test Certificates/Test Report](#)

[Special Test Certificate](#)

Marine / Shipping



Marine / Shipping	other	Railway
-------------------	-------	---------



[Confirmation](#)



[Confirmation](#)

[Special Test Certificate](#)

[Vibration and Shock](#)

Dangerous Good

[Transport Information](#)

Further information

Information- and Downloadcenter (Catalogs, Brochures,...)

<https://www.siemens.com/ic10>

Industry Mall (Online ordering system)

<https://mall.industry.siemens.com/mall/en/en/Catalog/product?mlfb=3RT2017-2LF42-1LA0>

Cax online generator

<http://support.automation.siemens.com/WW/CAXorder/default.aspx?lang=en&mlfb=3RT2017-2LF42-1LA0>

Service&Support (Manuals, Certificates, Characteristics, FAQs,...)

<https://support.industry.siemens.com/cs/ww/en/ps/3RT2017-2LF42-1LA0>

Image database (product images, 2D dimension drawings, 3D models, device circuit diagrams, EPLAN macros, ...)

http://www.automation.siemens.com/bilddb/cax_de.aspx?mlfb=3RT2017-2LF42-1LA0&lang=en

Characteristic: Tripping characteristics, I²t, Let-through current

<https://support.industry.siemens.com/cs/ww/en/ps/3RT2017-2LF42-1LA0/char>

Further characteristics (e.g. electrical endurance, switching frequency)

<http://www.automation.siemens.com/bilddb/index.aspx?view=Search&mlfb=3RT2017-2LF42-1LA0&objecttype=14&gridview=view1>

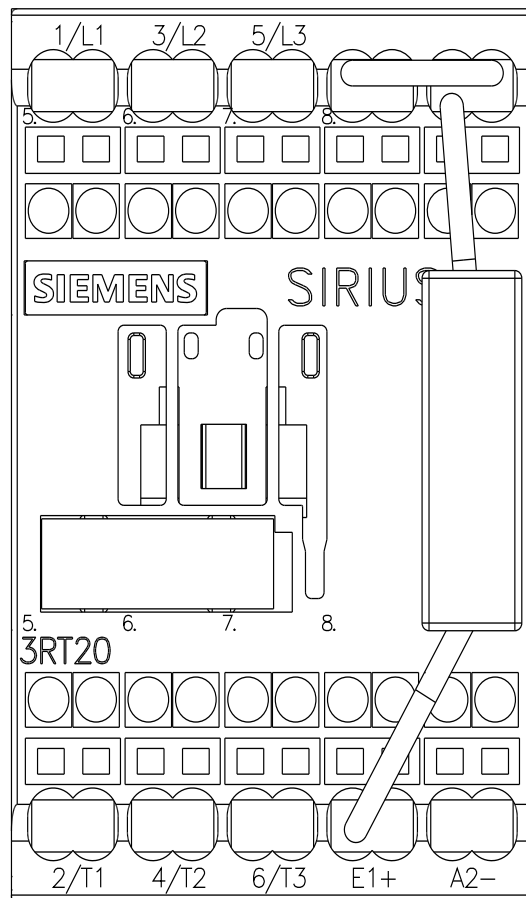
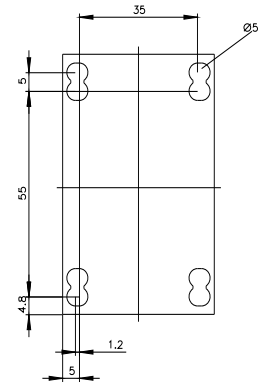
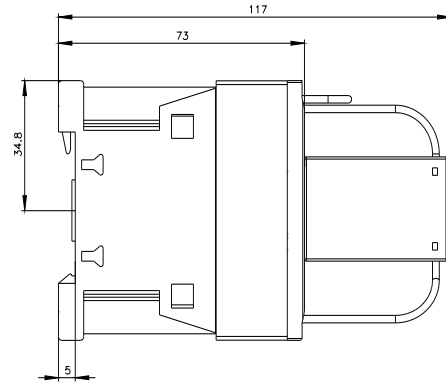
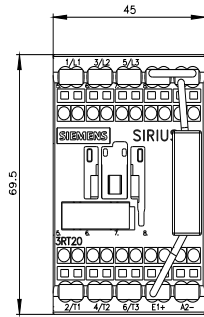

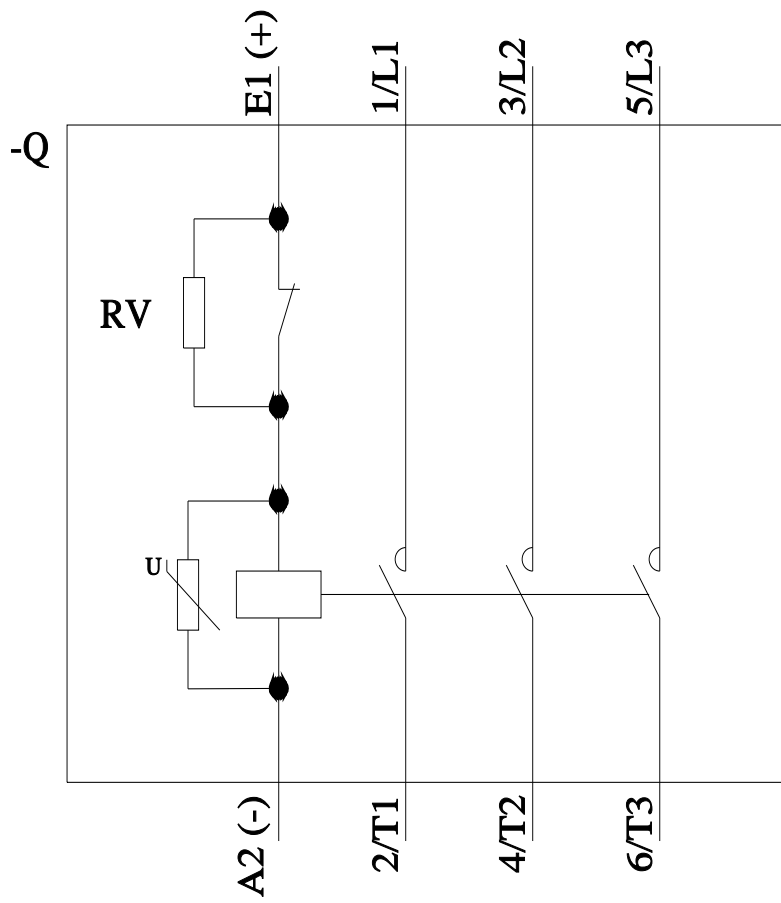

last modified:

11/21/2022 ↻