



power contactor, AC-3e/AC-3, 16 A, 7.5 kW / 400 V, 1 NO, 380 V AC, 50/60 Hz 3-pole, frame size S00 screw terminal

product brand name	SIRIUS
product designation	Power contactor
product type designation	3RT2
General technical data	
size of contactor	S00
product extension	
• function module for communication	No
• auxiliary switch	Yes
power loss [W] for rated value of the current	
• at AC in hot operating state	3 W
• at AC in hot operating state per pole	1 W
• without load current share typical	5.7 W
insulation voltage	
• of main circuit with degree of pollution 3 rated value	690 V
• of auxiliary circuit with degree of pollution 3 rated value	690 V
surge voltage resistance	
• of main circuit rated value	6 kV
• of auxiliary circuit rated value	6 kV
maximum permissible voltage for safe isolation between coil and main contacts according to EN 60947-1	400 V
shock resistance at rectangular impulse	
• at AC	7,3g / 5 ms, 4,7g / 10 ms
shock resistance with sine pulse	
• at AC	11,4g / 5 ms, 7,3g / 10 ms
mechanical service life (switching cycles)	
• of contactor typical	30 000 000
• of the contactor with added electronically optimized auxiliary switch block typical	5 000 000
• of the contactor with added auxiliary switch block typical	10 000 000
reference code according to IEC 81346-2	Q
Substance Prohibitance (Date)	10/01/2009
Ambient conditions	
installation altitude at height above sea level maximum	2 000 m
ambient temperature	
• during operation	-25 ... +60 °C
• during storage	-55 ... +80 °C
relative humidity minimum	10 %
relative humidity at 55 °C according to IEC 60068-2-30 maximum	95 %
Main circuit	

number of poles for main current circuit	3
number of NO contacts for main contacts	3
operating voltage	
• at AC-3 rated value maximum	690 V
• at AC-3e rated value maximum	690 V
operational current	
• at AC-1 at 400 V at ambient temperature 40 °C rated value	22 A
• at AC-1	
— up to 690 V at ambient temperature 40 °C rated value	22 A
— up to 690 V at ambient temperature 60 °C rated value	20 A
• at AC-3	
— at 400 V rated value	16 A
— at 500 V rated value	12.4 A
— at 690 V rated value	8.9 A
• at AC-3e	
— at 400 V rated value	16 A
— at 500 V rated value	12.4 A
— at 690 V rated value	8.9 A
• at AC-4 at 400 V rated value	11.5 A
• at AC-5a up to 690 V rated value	19.4 A
• at AC-5b up to 400 V rated value	13.2 A
• at AC-6a	
— up to 230 V for current peak value n=20 rated value	9.6 A
— up to 400 V for current peak value n=20 rated value	9.6 A
— up to 500 V for current peak value n=20 rated value	9.6 A
— up to 690 V for current peak value n=20 rated value	8.9 A
• at AC-6a	
— up to 230 V for current peak value n=30 rated value	6.6 A
— up to 400 V for current peak value n=30 rated value	6.4 A
— up to 500 V for current peak value n=30 rated value	6.4 A
— up to 690 V for current peak value n=30 rated value	6.4 A
minimum cross-section in main circuit at maximum AC-1 rated value	4 mm ²
operational current for approx. 200000 operating cycles at AC-4	
• at 400 V rated value	5.5 A
• at 690 V rated value	4.4 A
operational current	
• at 1 current path at DC-1	
— at 24 V rated value	20 A
— at 110 V rated value	2.1 A
— at 220 V rated value	0.8 A
— at 440 V rated value	0.6 A
— at 600 V rated value	0.6 A
• with 2 current paths in series at DC-1	
— at 24 V rated value	20 A
— at 110 V rated value	12 A
— at 220 V rated value	1.6 A
— at 440 V rated value	0.8 A
— at 600 V rated value	0.7 A
• with 3 current paths in series at DC-1	
— at 24 V rated value	20 A
— at 110 V rated value	20 A
— at 220 V rated value	20 A
— at 440 V rated value	1.3 A

<ul style="list-style-type: none"> — at 600 V rated value ● at 1 current path at DC-3 at DC-5 <ul style="list-style-type: none"> — at 24 V rated value — at 110 V rated value ● with 2 current paths in series at DC-3 at DC-5 <ul style="list-style-type: none"> — at 24 V rated value — at 110 V rated value ● with 3 current paths in series at DC-3 at DC-5 <ul style="list-style-type: none"> — at 24 V rated value — at 110 V rated value — at 220 V rated value — at 440 V rated value — at 600 V rated value 	<p>1 A</p> <p>20 A</p> <p>0.15 A</p> <p>20 A</p> <p>0.35 A</p> <p>20 A</p> <p>20 A</p> <p>1.5 A</p> <p>0.2 A</p> <p>0.2 A</p>
operating power	
<ul style="list-style-type: none"> ● at AC-2 at 400 V rated value ● at AC-3 <ul style="list-style-type: none"> — at 230 V rated value — at 400 V rated value — at 500 V rated value — at 690 V rated value ● at AC-3e <ul style="list-style-type: none"> — at 230 V rated value — at 400 V rated value — at 500 V rated value — at 690 V rated value 	<p>7.5 kW</p> <p>4 kW</p> <p>7.5 kW</p> <p>7.5 kW</p> <p>7.5 kW</p> <p>4 kW</p> <p>7.5 kW</p> <p>7.5 kW</p> <p>7.5 kW</p>
operating power for approx. 200000 operating cycles at AC-4	
<ul style="list-style-type: none"> ● at 400 V rated value ● at 690 V rated value 	<p>2.5 kW</p> <p>3.5 kW</p>
operating apparent power at AC-6a	
<ul style="list-style-type: none"> ● up to 230 V for current peak value n=20 rated value ● up to 400 V for current peak value n=20 rated value ● up to 500 V for current peak value n=20 rated value ● up to 690 V for current peak value n=20 rated value 	<p>3.8 kVA</p> <p>6.6 kVA</p> <p>8.3 kVA</p> <p>10.6 kVA</p>
operating apparent power at AC-6a	
<ul style="list-style-type: none"> ● up to 230 V for current peak value n=30 rated value ● up to 400 V for current peak value n=30 rated value ● up to 500 V for current peak value n=30 rated value ● up to 690 V for current peak value n=30 rated value 	<p>2.5 kVA</p> <p>4.4 kVA</p> <p>5.5 kVA</p> <p>7.6 kVA</p>
short-time withstand current in cold operating state up to 40 °C	
<ul style="list-style-type: none"> ● limited to 1 s switching at zero current maximum ● limited to 5 s switching at zero current maximum ● limited to 10 s switching at zero current maximum ● limited to 30 s switching at zero current maximum ● limited to 60 s switching at zero current maximum 	<p>300 A; Use minimum cross-section acc. to AC-1 rated value</p> <p>169 A; Use minimum cross-section acc. to AC-1 rated value</p> <p>128 A; Use minimum cross-section acc. to AC-1 rated value</p> <p>92 A; Use minimum cross-section acc. to AC-1 rated value</p> <p>74 A; Use minimum cross-section acc. to AC-1 rated value</p>
no-load switching frequency	
<ul style="list-style-type: none"> ● at AC 	<p>10 000 1/h</p>
operating frequency	
<ul style="list-style-type: none"> ● at AC-1 maximum ● at AC-2 maximum ● at AC-3 maximum ● at AC-3e maximum ● at AC-4 maximum 	<p>1 000 1/h</p> <p>750 1/h</p> <p>750 1/h</p> <p>750 1/h</p> <p>250 1/h</p>
Control circuit/ Control	
type of voltage of the control supply voltage	AC
control supply voltage at AC	
<ul style="list-style-type: none"> ● at 50 Hz rated value ● at 60 Hz rated value 	<p>380 V</p> <p>380 V</p>
operating range factor control supply voltage rated value of magnet coil at AC	
<ul style="list-style-type: none"> ● at 50 Hz ● at 60 Hz 	<p>0.8 ... 1.1</p> <p>0.85 ... 1.1</p>
apparent pick-up power of magnet coil at AC	

<ul style="list-style-type: none"> • at 50 Hz • at 60 Hz 	37 VA
inductive power factor with closing power of the coil	33 VA
<ul style="list-style-type: none"> • at 50 Hz • at 60 Hz 	0.8
apparent holding power of magnet coil at AC	0.75
<ul style="list-style-type: none"> • at 50 Hz • at 60 Hz 	5.7 VA
inductive power factor with the holding power of the coil	4.4 VA
<ul style="list-style-type: none"> • at 50 Hz • at 60 Hz 	0.25
closing delay	0.25
<ul style="list-style-type: none"> • at AC 	9 ... 35 ms
opening delay	
<ul style="list-style-type: none"> • at AC 	4 ... 15 ms
arcing time	10 ... 15 ms
control version of the switch operating mechanism	Standard A1 - A2

Auxiliary circuit

number of NO contacts for auxiliary contacts instantaneous contact	1
operational current at AC-12 maximum	10 A
operational current at AC-15	
<ul style="list-style-type: none"> • at 230 V rated value • at 400 V rated value • at 500 V rated value • at 690 V rated value 	10 A 3 A 2 A 1 A
operational current at DC-12	
<ul style="list-style-type: none"> • at 24 V rated value • at 48 V rated value • at 60 V rated value • at 110 V rated value • at 125 V rated value • at 220 V rated value • at 600 V rated value 	10 A 6 A 6 A 3 A 2 A 1 A 0.15 A
operational current at DC-13	
<ul style="list-style-type: none"> • at 24 V rated value • at 48 V rated value • at 60 V rated value • at 110 V rated value • at 125 V rated value • at 220 V rated value • at 600 V rated value 	10 A 2 A 2 A 1 A 0.9 A 0.3 A 0.1 A
contact reliability of auxiliary contacts	1 faulty switching per 100 million (17 V, 1 mA)

UL/CSA ratings

full-load current (FLA) for 3-phase AC motor	
<ul style="list-style-type: none"> • at 480 V rated value • at 600 V rated value 	14 A 11 A
yielded mechanical performance [hp]	
<ul style="list-style-type: none"> • for single-phase AC motor <ul style="list-style-type: none"> — at 110/120 V rated value — at 230 V rated value • for 3-phase AC motor <ul style="list-style-type: none"> — at 200/208 V rated value — at 220/230 V rated value — at 460/480 V rated value — at 575/600 V rated value 	1 hp 2 hp 3 hp 5 hp 10 hp 10 hp
contact rating of auxiliary contacts according to UL	A600 / Q600

Short-circuit protection

design of the fuse link	
<ul style="list-style-type: none"> • for short-circuit protection of the main circuit <ul style="list-style-type: none"> — with type of coordination 1 required — with type of assignment 2 required • for short-circuit protection of the auxiliary switch 	gG: 50A (690V,100kA), aM: 25A (690V,100kA), BS88: 50A (415V,80kA) gG: 25A (690V,100kA), aM: 20A (690V,100kA), BS88: 25A (415V,80kA) gG: 10 A (500 V, 1 kA)

required

Installation/ mounting/ dimensions

mounting position	+/-180° rotation possible on vertical mounting surface; can be tilted forward and backward by +/- 22.5° on vertical mounting surface
fastening method	screw and snap-on mounting onto 35 mm DIN rail according to DIN EN 60715
• side-by-side mounting	Yes
height	58 mm
width	45 mm
depth	73 mm
required spacing	
• with side-by-side mounting	
— forwards	10 mm
— upwards	10 mm
— downwards	10 mm
— at the side	0 mm
• for grounded parts	
— forwards	10 mm
— upwards	10 mm
— at the side	6 mm
— downwards	10 mm
• for live parts	
— forwards	10 mm
— upwards	10 mm
— downwards	10 mm
— at the side	6 mm

Connections/ Terminals

type of electrical connection	
• for main current circuit	screw-type terminals
• for auxiliary and control circuit	screw-type terminals
• at contactor for auxiliary contacts	Screw-type terminals
• of magnet coil	Screw-type terminals
type of connectable conductor cross-sections	
• for main contacts	
— solid	2x (0.5 ... 1.5 mm ²), 2x (0.75 ... 2.5 mm ²), 2x 4 mm ²
— solid or stranded	2x (0,5 ... 1,5 mm ²), 2x (0,75 ... 2,5 mm ²), 2x 4 mm ²
— finely stranded with core end processing	2x (0.5 ... 1.5 mm ²), 2x (0.75 ... 2.5 mm ²)
• at AWG cables for main contacts	2x (20 ... 16), 2x (18 ... 14), 2x 12
connectable conductor cross-section for main contacts	
• solid	0.5 ... 4 mm ²
• stranded	0.5 ... 4 mm ²
• finely stranded with core end processing	0.5 ... 2.5 mm ²
connectable conductor cross-section for auxiliary contacts	
• solid or stranded	0.5 ... 4 mm ²
• finely stranded with core end processing	0.5 ... 2.5 mm ²
type of connectable conductor cross-sections	
• for auxiliary contacts	
— solid or stranded	2x (0.5 ... 1.5 mm ²), 2x (0.75 ... 2.5 mm ²), 2x 4 mm ²
— finely stranded with core end processing	2x (0.5 ... 1.5 mm ²), 2x (0.75 ... 2.5 mm ²)
• at AWG cables for auxiliary contacts	2x (20 ... 16), 2x (18 ... 14), 2x 12
AWG number as coded connectable conductor cross section	
• for main contacts	20 ... 12
• for auxiliary contacts	20 ... 12

Safety related data

product function	
• mirror contact according to IEC 60947-4-1	Yes; with 3RH29
B10 value with high demand rate according to SN 31920	1 000 000
proportion of dangerous failures	
• with low demand rate according to SN 31920	40 %
• with high demand rate according to SN 31920	73 %
failure rate [FIT] with low demand rate according to SN	100 FIT

31920

T1 value for proof test interval or service life according to IEC 61508

20 y

protection class IP on the front according to IEC 60529

IP20

touch protection on the front according to IEC 60529 suitability for use

finger-safe, for vertical contact from the front

- safety-related switching OFF

Yes

Certificates/ approvals

General Product Approval



[Confirmation](#)



[KC](#)



EMC	Functional Safety/Safety of Machinery	Declaration of Conformity	Test Certificates
-----	---------------------------------------	---------------------------	-------------------



[Type Examination Certificate](#)



EG-Konf.

[Special Test Certificate](#)

[Type Test Certificates/Test Report](#)

Marine / Shipping



ABS



DNV



LRS



PRS



RINA

Marine / Shipping	other	Railway
-------------------	-------	---------



RMRS

[Confirmation](#)



VDE

[Confirmation](#)

[Vibration and Shock](#)

Further information

Information- and Downloadcenter (Catalogs, Brochures,...)

<https://www.siemens.com/ic10>

Industry Mall (Online ordering system)

<https://mall.industry.siemens.com/mall/en/en/Catalog/product?mlfb=3RT2018-1AQ01>

Cax online generator

<http://support.automation.siemens.com/WW/CAXorder/default.aspx?lang=en&mlfb=3RT2018-1AQ01>

Service&Support (Manuals, Certificates, Characteristics, FAQs,...)

<https://support.industry.siemens.com/cs/ww/en/ps/3RT2018-1AQ01>

Image database (product images, 2D dimension drawings, 3D models, device circuit diagrams, EPLAN macros, ...)

http://www.automation.siemens.com/bilddb/cax_de.aspx?mlfb=3RT2018-1AQ01&lang=en

Characteristic: Tripping characteristics, I²t, Let-through current

<https://support.industry.siemens.com/cs/ww/en/ps/3RT2018-1AQ01/char>

Further characteristics (e.g. electrical endurance, switching frequency)

<http://www.automation.siemens.com/bilddb/index.aspx?view=Search&mlfb=3RT2018-1AQ01&objecttype=14&gridview=view1>

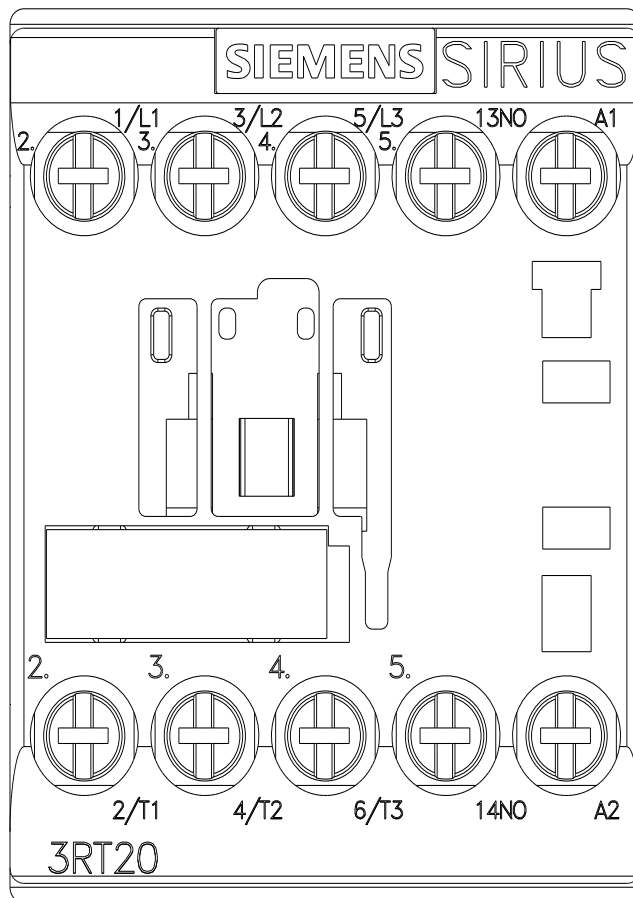
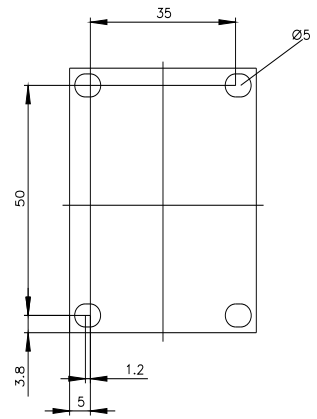
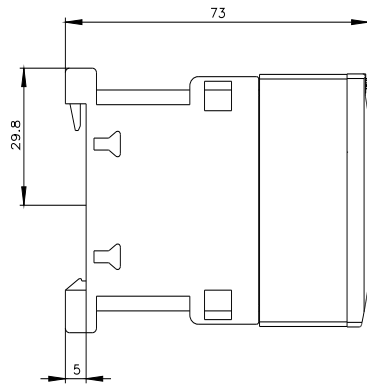
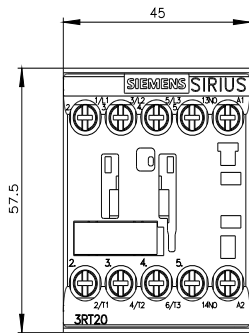



last modified:

11/21/2022 