



Circuit breaker size S00 for motor protection, CLASS 10 A-release 2.2...3.2 A N release 42 A screw terminal Standard switching capacity with transverse auxiliary switches 1 NO+1 NC

product brand name	SIRIUS
product designation	Circuit breaker
design of the product	For motor protection
product type designation	3RV2

### General technical data

size of the circuit-breaker	S00
size of contactor can be combined company-specific	S00, S0
product extension auxiliary switch	Yes
power loss [W] for rated value of the current	
• at AC in hot operating state	7.25 W
• at AC in hot operating state per pole	2.4 W
insulation voltage with degree of pollution 3 at AC rated value	690 V
surge voltage resistance rated value	6 kV
shock resistance according to IEC 60068-2-27	25g / 11 ms
mechanical service life (switching cycles)	
• of the main contacts typical	100 000
• of auxiliary contacts typical	100 000
electrical endurance (switching cycles) typical	100 000
type of protection according to ATEX directive 2014/34/EU	Ex II (2) GD
certificate of suitability according to ATEX directive 2014/34/EU	DMT 02 ATEX F 001
reference code according to IEC 81346-2	Q
Substance Prohibitance (Date)	10/01/2009

### Ambient conditions

installation altitude at height above sea level maximum	2 000 m
ambient temperature	
• during operation	-20 ... +60 °C
• during storage	-50 ... +80 °C
• during transport	-50 ... +80 °C
relative humidity during operation	10 ... 95 %

### Main circuit

number of poles for main current circuit	3
adjustable current response value current of the current-dependent overload release	2.2 ... 3.2 A
operating voltage	
• rated value	20 ... 690 V
• at AC-3 rated value maximum	690 V
• at AC-3e rated value maximum	690 V
operating frequency rated value	50 ... 60 Hz
operational current rated value	3.2 A

<b>operational current</b>	
• at AC-3 at 400 V rated value	3.2 A
• at AC-3e at 400 V rated value	3.2 A
<b>operating power</b>	
• at AC-3	
— at 230 V rated value	0.6 kW
— at 400 V rated value	1.1 kW
— at 500 V rated value	1.5 kW
— at 690 V rated value	2.2 kW
• at AC-3e	
— at 230 V rated value	0.6 kW
— at 400 V rated value	1.1 kW
— at 500 V rated value	1.5 kW
— at 690 V rated value	2.2 kW
<b>operating frequency</b>	
• at AC-3 maximum	15 1/h
• at AC-3e maximum	15 1/h

### Auxiliary circuit

<b>design of the auxiliary switch</b>	transverse
<b>number of NC contacts for auxiliary contacts</b>	1
<b>number of NO contacts for auxiliary contacts</b>	1
number of CO contacts for auxiliary contacts	0
<b>operational current of auxiliary contacts at AC-15</b>	
• at 24 V	2 A
• at 120 V	0.5 A
• at 125 V	0.5 A
• at 230 V	0.5 A
<b>operational current of auxiliary contacts at DC-13</b>	
• at 24 V	1 A
• at 60 V	0.15 A

### Protective and monitoring functions

<b>product function</b>	
• ground fault detection	No
• phase failure detection	Yes
<b>trip class</b>	CLASS 10
<b>design of the overload release</b>	thermal
<b>breaking capacity maximum short-circuit current (I<sub>cu</sub>)</b>	
• at AC at 240 V rated value	100 kA
• at AC at 400 V rated value	100 kA
• at AC at 500 V rated value	100 kA
• at AC at 690 V rated value	10 kA
<b>breaking capacity operating short-circuit current (I<sub>cs</sub>) at AC</b>	
• at 240 V rated value	100 kA
• at 400 V rated value	100 kA
• at 500 V rated value	100 kA
• at 690 V rated value	10 kA
response value current of instantaneous short-circuit trip unit	42 A

### UL/CSA ratings

<b>full-load current (FLA) for 3-phase AC motor</b>	
• at 480 V rated value	3.2 A
• at 600 V rated value	3.2 A
<b>yielded mechanical performance [hp]</b>	
• for single-phase AC motor	
— at 110/120 V rated value	0.1 hp
— at 230 V rated value	0.25 hp
• for 3-phase AC motor	
— at 200/208 V rated value	0.5 hp
— at 220/230 V rated value	0.75 hp
— at 460/480 V rated value	2 hp
— at 575/600 V rated value	2 hp
<b>contact rating of auxiliary contacts according to UL</b>	C300 / R300

## Short-circuit protection

<b>product function short circuit protection</b>	Yes
<b>design of the short-circuit trip</b>	magnetic
<b>design of the fuse link</b> <ul style="list-style-type: none"><li>• for short-circuit protection of the auxiliary switch required</li></ul>	Fuse gL/gG: 10 A, miniature circuit breaker C 6 A (short-circuit current $I_{lk} < 400$ A)
<b>design of the fuse link for IT network for short-circuit protection of the main circuit</b> <ul style="list-style-type: none"><li>• at 400 V</li><li>• at 500 V</li><li>• at 690 V</li></ul>	gL/gG 25 A gL/gG 32 A gL/gG 25 A

## Installation/ mounting/ dimensions

<b>mounting position</b>	any
<b>fastening method</b>	screw and snap-on mounting onto 35 mm DIN rail according to DIN EN 60715
<b>height</b>	97 mm
<b>width</b>	45 mm
<b>depth</b>	97 mm
<b>required spacing</b> <ul style="list-style-type: none"><li>• with side-by-side mounting at the side</li><li>• for grounded parts at 400 V<ul style="list-style-type: none"><li>— downwards</li><li>— upwards</li><li>— at the side</li></ul></li><li>• for live parts at 400 V<ul style="list-style-type: none"><li>— downwards</li><li>— upwards</li><li>— at the side</li></ul></li><li>• for grounded parts at 500 V<ul style="list-style-type: none"><li>— downwards</li><li>— upwards</li><li>— at the side</li></ul></li><li>• for live parts at 500 V<ul style="list-style-type: none"><li>— downwards</li><li>— upwards</li><li>— at the side</li></ul></li><li>• for grounded parts at 690 V<ul style="list-style-type: none"><li>— downwards</li><li>— upwards</li><li>— backwards</li><li>— at the side</li><li>— forwards</li></ul></li><li>• for live parts at 690 V<ul style="list-style-type: none"><li>— downwards</li><li>— upwards</li><li>— backwards</li><li>— at the side</li><li>— forwards</li></ul></li></ul>	0 mm 30 mm 30 mm 9 mm 30 mm 30 mm 9 mm 30 mm 30 mm 9 mm 50 mm 50 mm 0 mm 30 mm 0 mm 50 mm 50 mm 0 mm 30 mm 0 mm

## Connections/ Terminals

<b>type of electrical connection</b> <ul style="list-style-type: none"><li>• for main current circuit</li><li>• for auxiliary and control circuit</li></ul>	screw-type terminals screw-type terminals
<b>arrangement of electrical connectors for main current circuit</b>	Top and bottom
<b>type of connectable conductor cross-sections</b> <ul style="list-style-type: none"><li>• for main contacts<ul style="list-style-type: none"><li>— solid or stranded</li><li>— finely stranded with core end processing</li></ul></li><li>• at AWG cables for main contacts</li></ul>	2x (0,75 ... 2,5 mm <sup>2</sup> ), 2x 4 mm <sup>2</sup> 2x (0.5 ... 1.5 mm <sup>2</sup> ), 2x (0.75 ... 2.5 mm <sup>2</sup> ) 2x (18 ... 14), 2x 12
<b>type of connectable conductor cross-sections</b> <ul style="list-style-type: none"><li>• for auxiliary contacts<ul style="list-style-type: none"><li>— solid or stranded</li><li>— finely stranded with core end processing</li></ul></li><li>• at AWG cables for auxiliary contacts</li></ul>	2x (0.5 ... 1.5 mm <sup>2</sup> ), 2x (0.75 ... 2.5 mm <sup>2</sup> ) 2x (0.5 ... 1.5 mm <sup>2</sup> ), 2x (0.75 ... 2.5 mm <sup>2</sup> ) 2x (20 ... 16), 2x (18 ... 14)

**tightening torque**

- for main contacts with screw-type terminals
- for auxiliary contacts with screw-type terminals

0.8 ... 1.2 N·m  
 0.8 ... 1.2 N·m  
 Diameter 5 to 6 mm  
 Pozidriv size 2

**design of screwdriver shaft****size of the screwdriver tip****design of the thread of the connection screw**

- for main contacts
- of the auxiliary and control contacts

M3  
 M3

**Safety related data****B10 value**

- with high demand rate according to SN 31920

5 000

**proportion of dangerous failures**

- with low demand rate according to SN 31920
- with high demand rate according to SN 31920

50 %  
 50 %

**failure rate [FIT]**

- with low demand rate according to SN 31920

50 FIT

T1 value for proof test interval or service life according to IEC 61508

10 y

**protection class IP on the front according to IEC 60529**

IP20

**touch protection on the front according to IEC 60529**  
 display version for switching status

finger-safe, for vertical contact from the front  
 Handle

**Certificates/ approvals****General Product Approval**

[Confirmation](#)



[KC](#)

**For use in hazardous locations****Declaration of Conformity****Test Certificates**

[Special Test Certificate](#)

[Type Test Certificates/Test Report](#)

**Marine / Shipping****Marine / Shipping****other****Railway**

[Confirmation](#)



[Confirmation](#)

[Vibration and Shock](#)

**Further information**

Information- and Downloadcenter (Catalogs, Brochures,...)

<https://www.siemens.com/ic10>

Industry Mall (Online ordering system)

<https://mall.industry.siemens.com/mall/en/en/Catalog/product?mlfb=3RV2011-1DA15>

Cax online generator

<http://support.automation.siemens.com/WW/CAXorder/default.aspx?lang=en&mlfb=3RV2011-1DA15>

Service&Support (Manuals, Certificates, Characteristics, FAQs,...)

<https://support.industry.siemens.com/cs/ww/en/ps/3RV2011-1DA15>

Image database (product images, 2D dimension drawings, 3D models, device circuit diagrams, EPLAN macros, ...)

[http://www.automation.siemens.com/bilddb/cax\\_de.aspx?mlfb=3RV2011-1DA15&lang=en](http://www.automation.siemens.com/bilddb/cax_de.aspx?mlfb=3RV2011-1DA15&lang=en)

Characteristic: Tripping characteristics, I<sup>t</sup>, Let-through current

<https://support.industry.siemens.com/cs/ww/en/ps/3RV2011-1DA15/char>

Further characteristics (e.g. electrical endurance, switching frequency)

<http://www.automation.siemens.com/bilddb/index.aspx?view=Search&mlfb=3RV2011-1DA15&objecttype=14&gridview=view1>

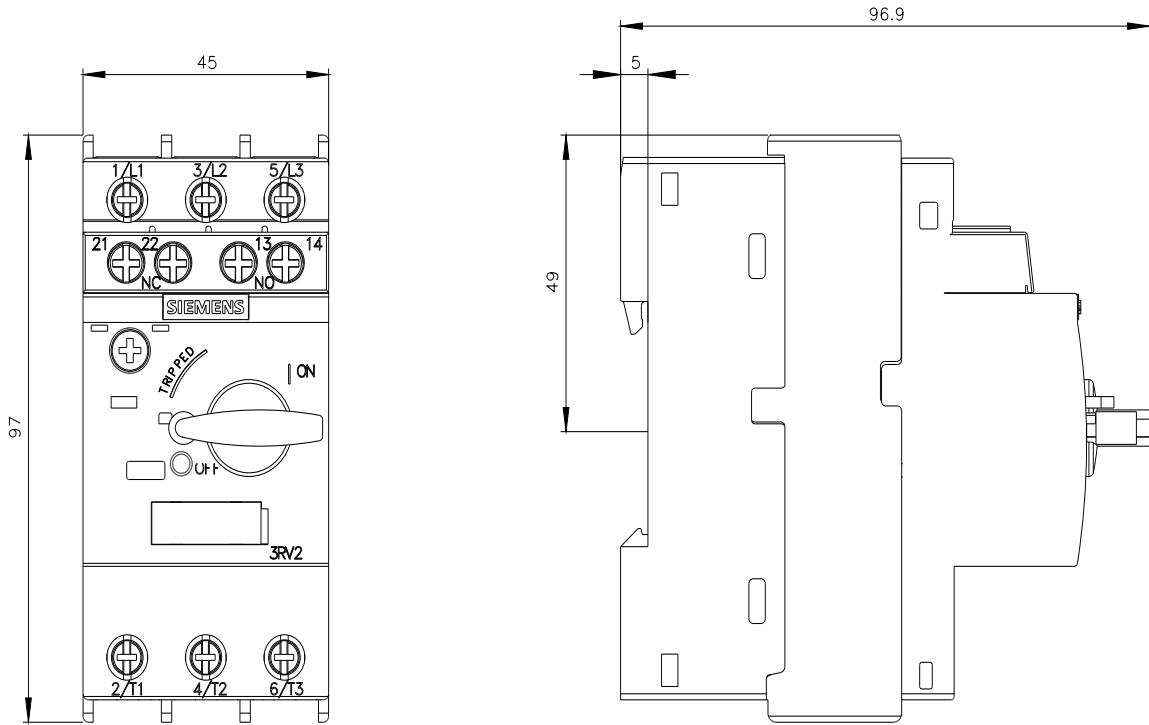

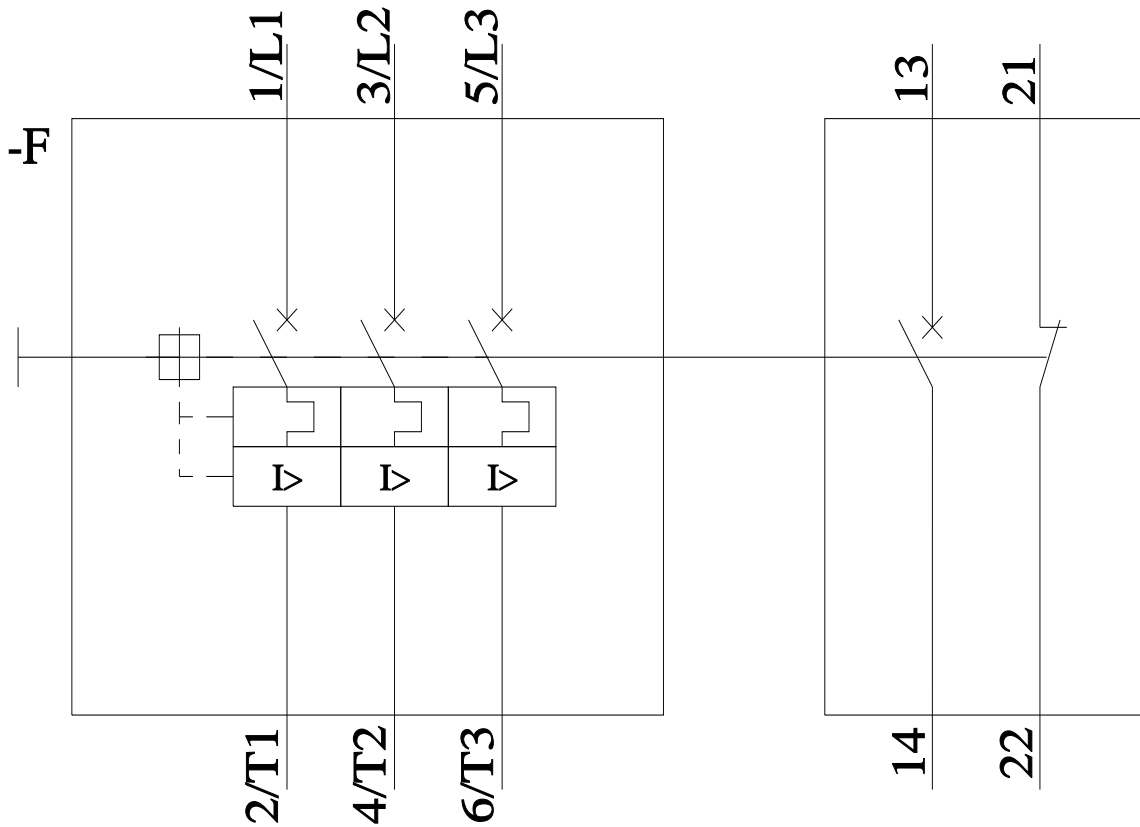
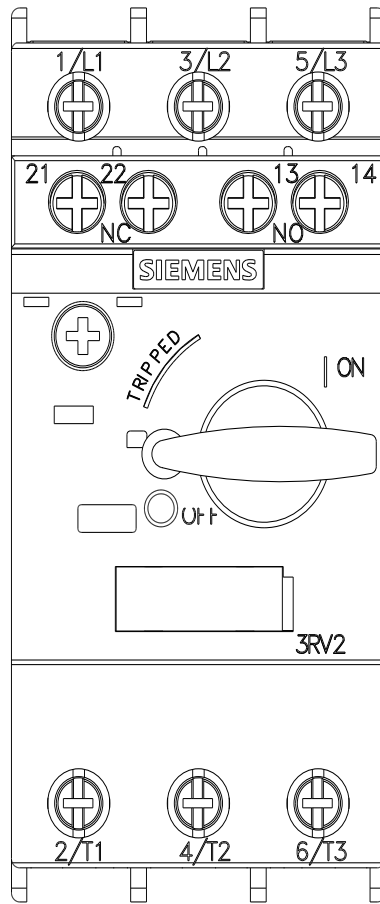

last modified:

11/21/2022 