

## Safety notes

This product may be installed only by a qualified electrician. Non-compliance may result in a fire hazard or electric shocks. Before installation, read the operating instructions and observe the product-specific requirements for the installation location. Use only original spare parts for repair and maintenance. Unauthorised opening and repair by other persons will invalidate all claims for liability, replacement or warranty services. When operated from the mains voltage, the time switch may not be used to switch safe extra-low voltages (SELV). When operated from a safe extra-low voltage, it may not be used to switch mains voltages.

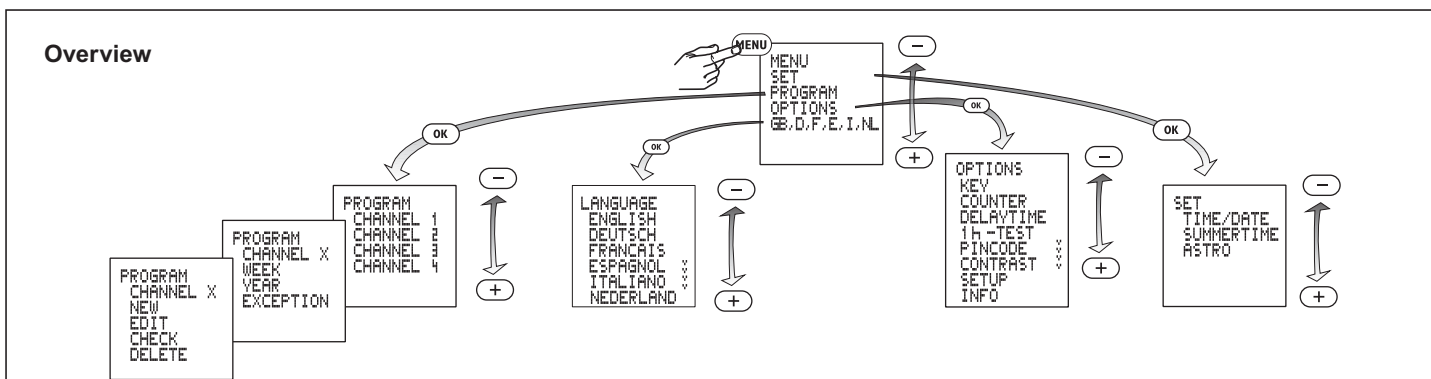
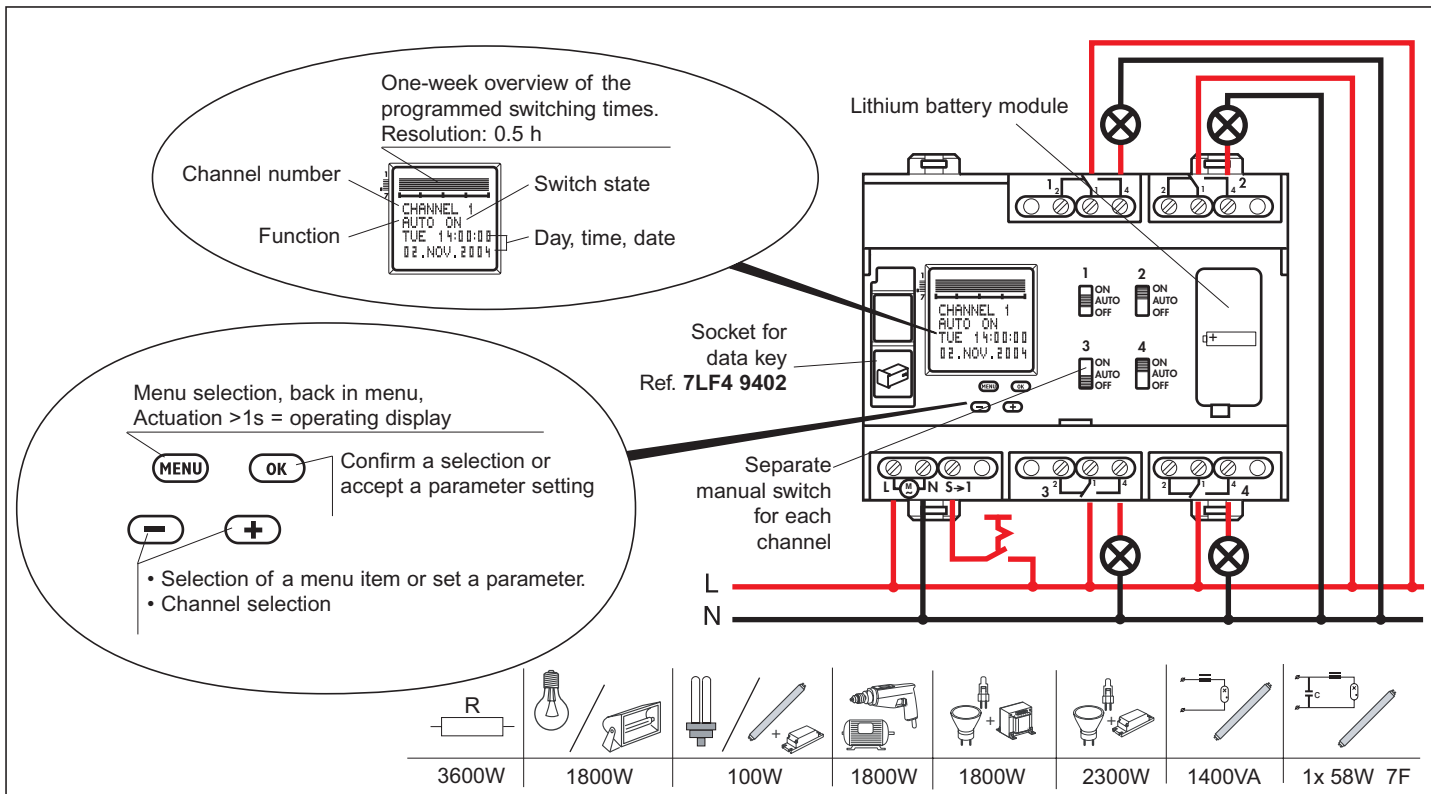

## Technical data

	7LF4 4440	7LF4 4442		
Supply voltage:	120 / 230V 50/60Hz	24 AC/DC ±10%	Delay time:	0 ... 23 h 59 min 59 s
Power consumption:	approx. 0,3...2 W	approx. 3...4 W	Local coordinates:	Resolution 1°
Relay outputs 1- 4:	4 changeover contacts 16A 250V~ cos φ = 1		Battery reserve:	5 years
Accuracy:	± 0,2 s/day under typical installation conditions		Storage temperature:	- 20°C to +60°C
	single-strand	multi-strand	Operating principle:	Typ 1.B. S. T. IEC/EN 60730-2-7
Wire cross-sections:	1,5...4 mm <sup>2</sup>	1,5...2,5 mm <sup>2</sup>	Working ambient:	- 20°C to +55°C
Programs	4 channels x 3 program types x 28 programs		Degree of contamination:	2
Control signal for channel 1:	supply voltage, referred to neutral		Installation:	in distribution panel
Control-pulse duration:	> 200ms			
Control-wire length:	max. 50m			

## General information

- **Starting:** After connection of the supply voltage, the clock starts to run with the last selected function. The relay position is determined by the currently active program.
- **Backup battery operation mode:**
  - **background lighting** not available.
  - **data key READ/WRITE** only via the menu.
- If, during programming, no key is pressed for 60 seconds, the timer automatically switches from the menu display to the normal operating display.

### 1 Select language

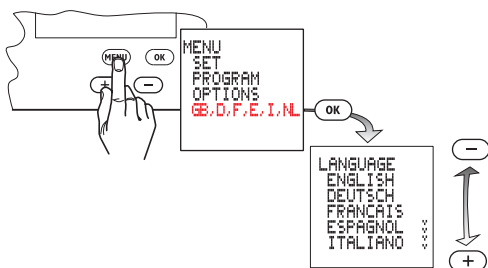

### 2 Setting

#### A Time and date

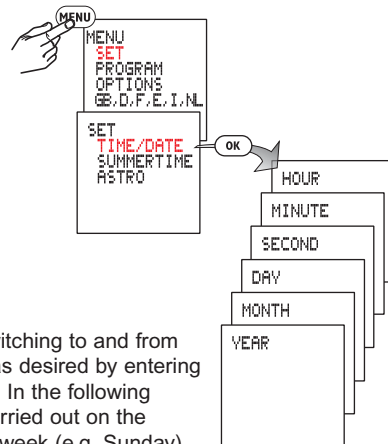

#### B Summer time +1h

**Europe:** factory setting.

**Special:** The dates for switching to and from summer time can be set as desired by entering a start date and end date. In the following years, switching will be carried out on the corresponding day of the week (e.g. Sunday).

#### C Astro

Select country.  
Select the city closest to the planned location for use.

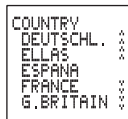

You can adjust the coordinates more precisely with **LONGITUDE** and **LATITUDE**.

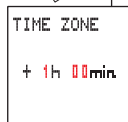

Use the enclosed **time-zone map** to set the correct time zone.

From this map, determine the difference between local time and UTC (Universal Time Coordinated) and set this value.

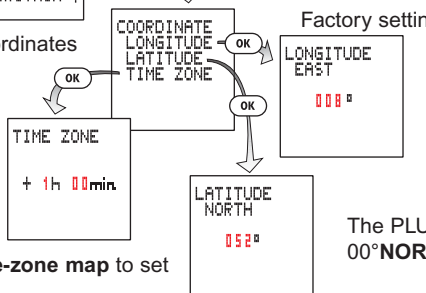

Factory setting: 8°E 52°N

The **MINUS** key is used to adjust the westward longitude value in the range from 000°EAST/WEST to 180°WEST.

The **PLUS** key is used to adjust the eastward longitude value in the range from 000°EAST/WEST to 180°EAST.

The **PLUS** key is used to adjust the northward latitude value in the range from 00°NORTH/SOUTH to 90°NORTH.

The **MINUS** key is used to adjust the southward latitude value in the range from 00°NORTH/SOUTH to 90°SOUTH.

#### D Offset

The time switch switches on at the calculated sunset time and off at the calculated sunrise time.

By setting an offset, you can shift the switching times by up to ±120 minutes with respect to the calculated sunrise and sunset times.

**Example:** If you set the offset to +30 minutes, the time switch will switch 30 minutes after sunrise and 30 minutes after sunset.

If you set the offset to -30 minutes, the time switch will switch 30 minutes before sunrise and 30 minutes before sunset.

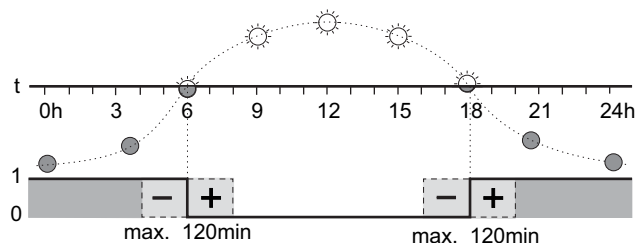
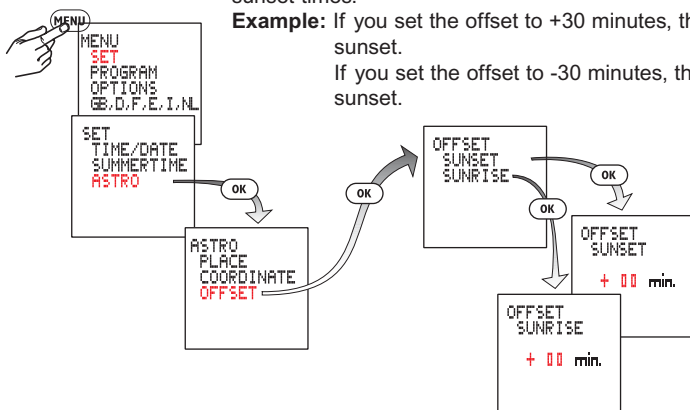

### 3A PROGRAM / WEEK

This menu item is provided for the simple input of programs which are to be repeated weekly (such as switching of lights and boilers). A weekly program consists of an ON time, an OFF time and the associated ON and OFF days.

- MON TO SUN: the days of the week are already assigned and you only need to set the ON and OFF times. This is used where the same program is to be executed on every day of the week.
- INDIVIDUAL: you can assign the ON and OFF times to any desired days. This is used where the same program is to be executed only on certain days of the week or different programs are to be executed on the various days.

#### OR function

The programs defined for each channel are ORed together. In other words, the output will be active if this is defined in any of the programs. Example: channel 1



#### Sample WEEK program

The timer is to switch on at sunset on each day of the week and switch off at sunrise.

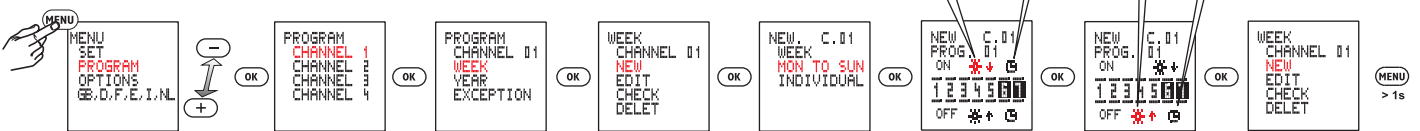

### 3B PROGRAM / YEAR

This menu item permits the input of (additional) annual programs which are to be executed only during a specified period. These programs and the weekly programs of the same channel are ORed together as described above.

The period during which a program is to be executed is defined by entering a start date and an end date.

- The option EVERY YEAR should be selected if the additional program is to be executed during the same period of each year (e.g. Christmas, national holidays, birthdays, etc.).
- The option ONCE should be selected if the additional program is to be executed only during a single period (e.g. vacation period), but the start and end dates of this period are different in each year.

#### Sample YEAR program

Channel 2 is to be activated each year on at 09:00 hours on 01.11. and deactivated at 23:00 hours.

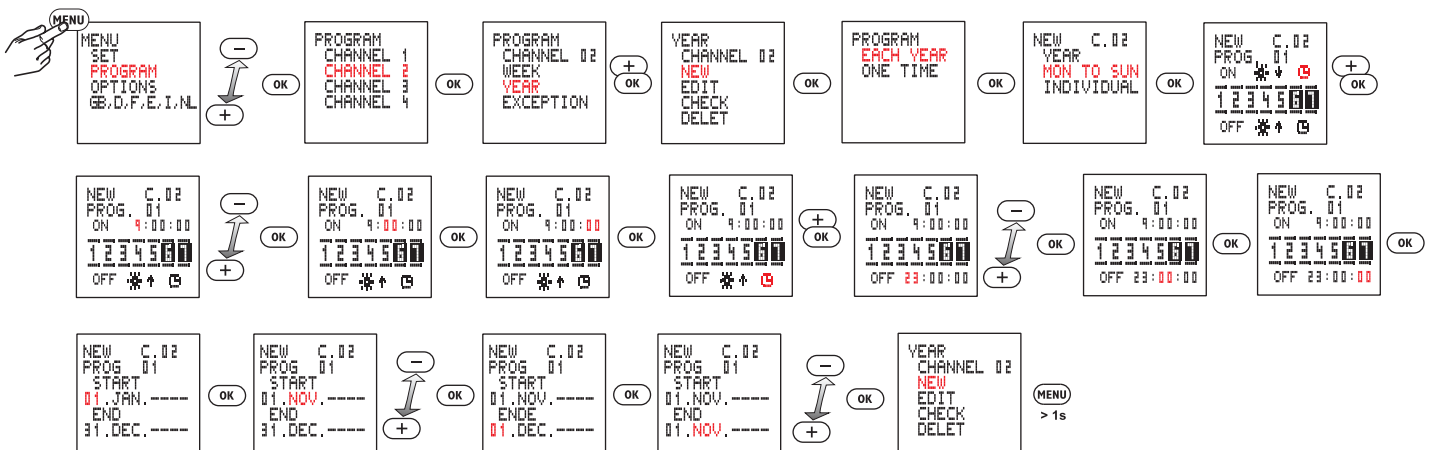

### 3C PROGRAM / EXCEPTION

The weekly and annual programs defined for a channel are not executed as long as an extra program is active.

However, other exception programs will be executed while an exception program is active.

The various exception programs are ORed together as described above. (see OR function 3a)

- The option EVERY YEAR should be selected if the exception program is to be activated for the same period in each year (e.g. Christmas, national holidays, birthdays, etc.).
- The option ONCE should be selected if the exception program is to be activated only during a single period (e.g. vacation period), but the start and end dates of this period are different in each year.
- Option MON TO SUN: the exception program is active from 00:00 hours on the start date to 24:00 hours on the end date. During this period, the output of the related channel switches only as defined in the exception program.
- Option INDIVIDUAL: the exception program is active from 00:00 hours on the start date to 24:00 hours on the end date. During this period, the output of the related channel switches only as defined in the exception program.
- Option PROG ON: the exception program is active from the ON time on the start date to OFF time on the end date. During this period, the output of the channel is permanently on.
- Option PROG OFF: the exception program is active from the ON time on the start date to OFF time on the end date. During this period, the output of the channel is permanently off.

#### Sample EXCEPTION programs

① Channel 2 is to be switched off each year for the entire period 01.08. to 31.08.

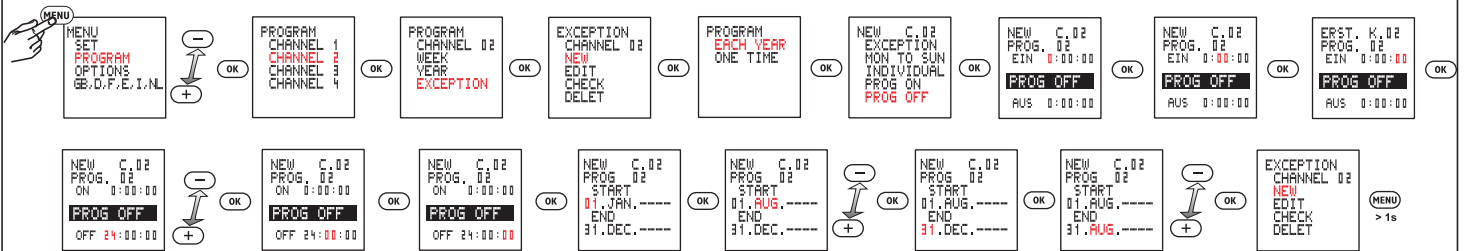

② Each year from 25.12. to 26.12., channel 2 is to be switched on at 6:00 hours, switched off at sunrise, switched on at sunset and switched off at 23:00 hours. For this, two programs are needed:

Program 1: ON at 6:00 and OFF at sunrise

Program 2: ON at sunset and OFF at 23:00

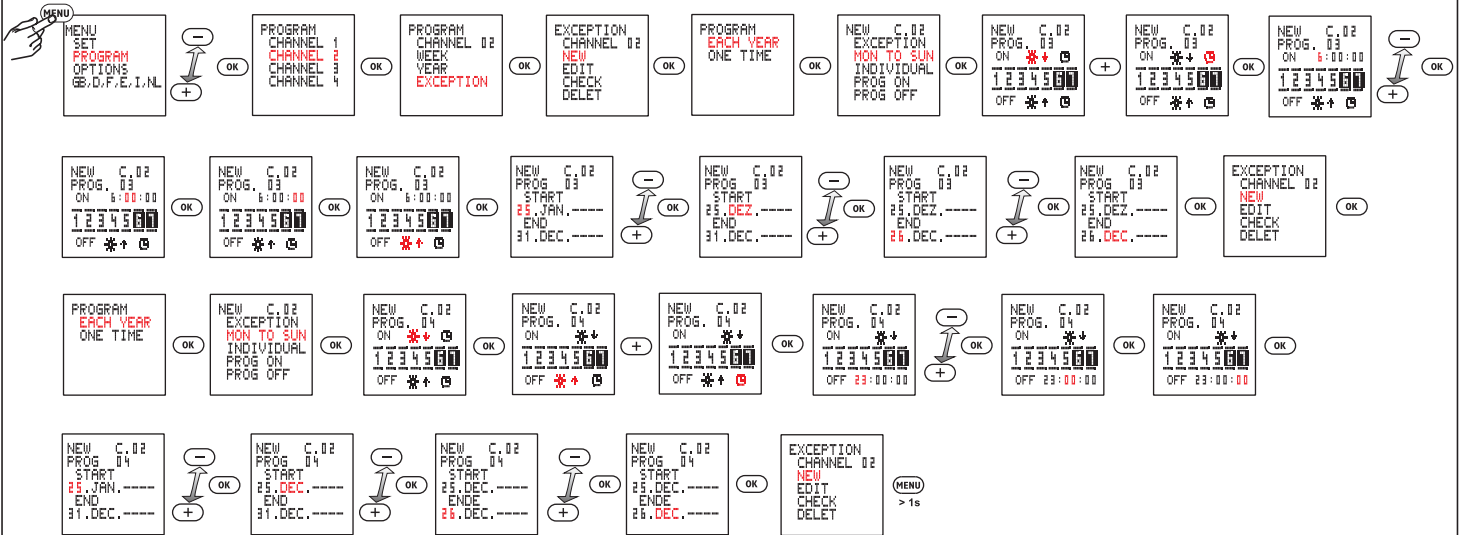

### 3D PROGRAM Edit/Check/Delete

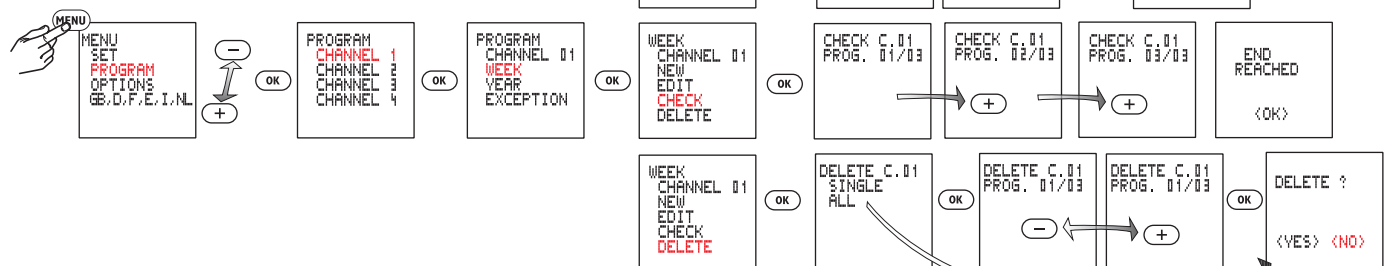

Required inputs, depending on the program type and menu options.

Program type	Execution	Characteristics	ON/OFF times	Weekday assignments	Active period START date	Active period END date	Application, objectives, examples
WEEK	Repeated weekly	MON TO SUN	●	○	○	○	The same switching cycle is to be executed on every day of each week. Example: switch lights on at sunset and off at 22:30:00 hours each day.
		INDIVIDUAL	●	●	○	○	A switching cycle is to be executed only on specific days of each week. Example: switch lights on at sunset and off at 22:30:00 hours on Monday to Friday of each week.
YEAR	EVERY YEAR	MON TO SUN	●	○	Day, month, ----	Day, month, ----	<ul style="list-style-type: none"> <li>A switching cycle is to be executed on each day within a specified period of each year. Example: switch on the outside lights of a church from 17:00:00 to 24:00:00 in the period 1 December to 6 January.</li> <li>An existing weekly program is to be supplemented with additional switching times on each day during a specific period of each year.</li> </ul>
		INDIVIDUAL	●	●	Day, month, ----	Day, month, ----	<ul style="list-style-type: none"> <li>A switching cycle is to be executed on certain days of the week within a specified period of each year. Example: switch on the outside lights of a church from 17:00:00 to 24:00:00 on each Sunday in the period 1 December to 6 January.</li> <li>An existing weekly program is to be supplemented with additional switching times on certain days of the week during a specific period of each year.</li> </ul>
	ONCE	MON TO SUN	●	○	Day, month, year	Day, month, year	<ul style="list-style-type: none"> <li>A switching cycle is to be executed on each day of a specified period in a specified year. Example: in the year 2005, the heating in a holiday chalet is to be switched on from 07:30:00 to 23:00:00 on each day during the Easter holidays (25 March to 28 March 2005).</li> <li>An existing weekly program is to be supplemented with additional switching times on each day during a specific period of a specific year.</li> </ul>
		INDIVIDUAL	●	●	Day, month, year	Day, month, year	<ul style="list-style-type: none"> <li>A switching cycle is to be executed on certain days of a specified period in a specified year. Example: in the current year, the lights in a sports hall are to be switched on from 19:00:00 to 22:00:00 on each Tuesday and Friday during the period from 10 January to 23 March.</li> <li>An existing weekly program is to be supplemented with additional switching times on certain days of the week during a specific period of a specific each year.</li> </ul>

Program type	Execution	Characteristics	ON/OFF times	Weekday assignments	Active period START date	Active period END date	Application, objectives, examples
EXCEPTION	EVERY YEAR	MON TO SUN	●	○	Day, month, ---- from 0:00:00 hours	Day, month, ---- to 24:00:00 hours	An exception program is to completely replace any existing weekly or annual program on each day during a specific period of each year. Example: the irrigation pump of an orchard is to be switched on from 17:00:00 to 18:00:00 on each day in the period from 20.March ---- to 10.April ----.
		INDIVIDUAL	●	●	Day, month, ---- from 0:00:00 hours	Day, month, ---- to 24:00:00 hours	An exception program is to completely replace any existing weekly or annual program on certain days during a specific period of each year. Example: the irrigation pump of an orchard is to be switched on from 17:00:00 to 18:00:00 on each Monday and Friday in the period from 11 April ---- to 15 May ----.
		PROG ON	●	○	Day, month, ---- from ON time	Day, month, ---- to OFF time	A channel is to be switched on continuously from the ON time on the START date to the OFF time on the END date every year. This exception program is to completely replace any existing weekly or annual program for this channel. Example: instead of the normal times for illumination of a public building, the illumination is to be switched on from 17:00:00 on the national holiday 3 October ---- until 07:00:00 the next morning 4 October ----.
		PROG OFF	●	○	Day, month, ---- from ON time	Day, month, ---- to OFF time	An output is to be switched off continuously from the ON time on the START date to the OFF time on the END date every year. This exception program is to completely replace any existing weekly or annual program for this channel. Example: in order to save power, certain equipment in a factory is to be switched off during the Christmas holiday period of each year. i.e. from 18:00:00 on 23 December ---- to 6:00:00 on 27 December ----.
	ONCE	MON TO SUN	●	○	Day, month, year from 0:00:00 hours	Day, month, year to 24:00:00 hours	On each day during a specific period of a specified year, an exception program is to completely replace any existing weekly or annual program. Example: during the Christmas holidays of the year 2005, the heating in an apartment is to be switched each day from 7:00:00 to 23:00:00, instead of in the normal cycle. This exception period is to begin on 24 December 2005 and end on 06 January 2006.
		INDIVIDUAL	●	●	Day, month, year from 0:00:00 hours	Day, month, year to 24:00:00 hours	On certain weekdays during a specific period of a specific year, an exception program is to completely replace any existing weekly or annual program. Example: in December 2005, the heating system of a department store is to be switched on from 8:00:00 to 18:00:00 each Sunday, because the store opens on Sundays in the period 4 December 2005 to 18 December 2005.
		PROG ON	●	○	Day, month, year from ON time	Day, month, year to OFF time	A channel is to be switched on continuously from the ON time on the START date to the OFF time on the END date of a specific year. This exception program is to completely replace any existing weekly or annual program for this channel. Example: the alarm system of an office building is to be switched on continuously during the vacation period 19:00:00 on 15 July 2005 to 06:00:00 on 7 August 2005.
		PROG OFF	●	○	Day, month, year from ON time	Day, month, year to OFF time	A channel is to be switched off continuously from the ON time on the START date to the OFF time on the END date of a specific year. This exception program is to completely replace any existing weekly or annual program for this channel. Example: in 2005, the normal recess gong in a school is to be switched off during the summer holidays 00:00:00 on 28 July 2005 to 24:00:00 on 10 September 2005.

Select the option PROGRAM / WEEK for a program which is to be executed a on specific days of the week and is to be repeated weekly.

Select the option PROGRAM / YEAR for a program which is to be executed each year or only in a specific year. The execution period within the year can be defined by entering start and end dates.

Select the option PROGRAM / EXCEPTION for a program which is to completely replace existing weekly or annual programs during a specified period.

**Priorities of the various program types within the same channel:**

	WEEK program	YEAR program	EXCEPTION program
WEEK program	The various weekly programs are ORed together	The various weekly and annual programs are ORed together	The exception program is overriding within its defined period of activity.
YEAR program	The various weekly and annual programs are ORed together	The various annual programs are ORed together	The exception program is overriding within its defined period of activity.
EXCEPTION program	The exception program is overriding within its defined period of activity.	The exception program is overriding within its defined period of activity.	The various exception programs are ORed together

**4 Data key (Color anthracite)**

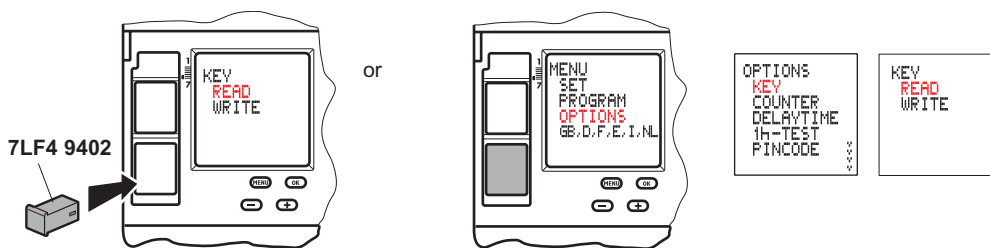

**Load the programs from the data key to the time switch (READ KEY)**

**Warning!** all programs already programmed in the time switch will be overwritten.

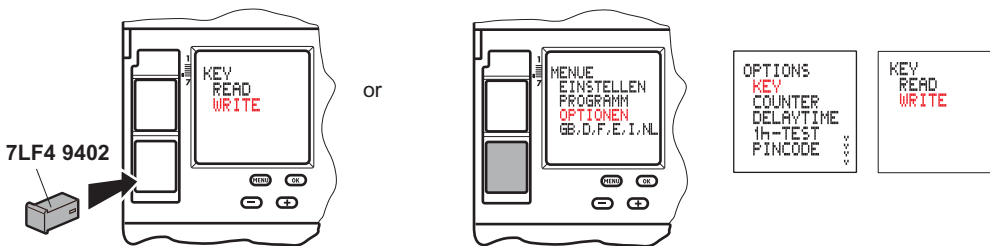

**Load the programs of the time switch on to a data key (WRITE KEY)**

**Warning!** all programs already existing on the data key will be overwritten.

## 5 Operating-hours counter

This displays the total duration of the ON times, from 0 to 065535 hours, and the date on which this counter was last reset.

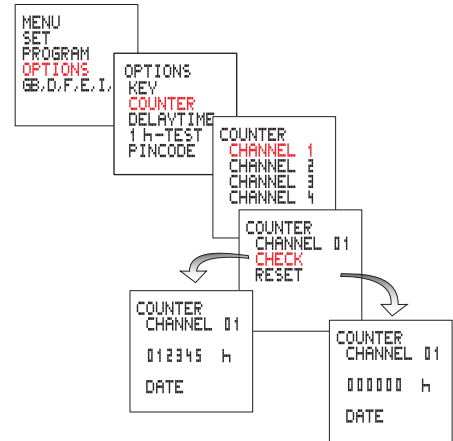

## 6 Contrast adjustment

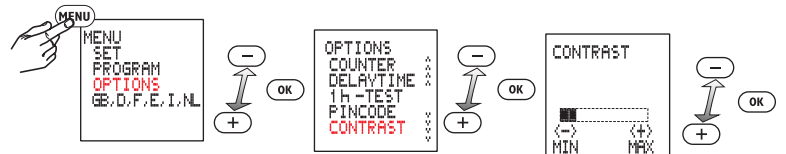

## 7 1 h-Test

If this menu item is activated, the outputs are switched on for one hour.  
The test can be **terminated** at any time by selecting the option **PASSIVE**.

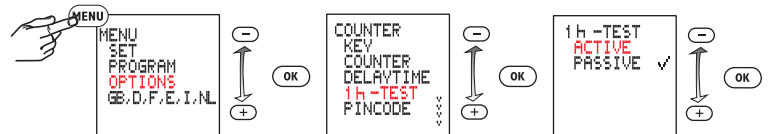

## 8 Pincode (access protection)

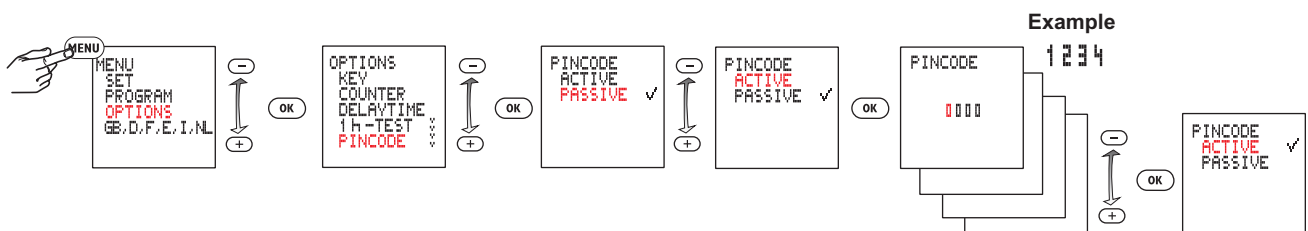

PINCODE active: the PINCODE must be entered before the timer switch can be operated.  
The access protection can be cancelled by selecting PASSIVE. It is also cancelled by a reset.

## Reset

### Note!

A reset clears the entire memory, which means that all previously set data will be lost.  
Press and hold all four keys together for about 2 seconds, then release them.  
After a reset, the language, time and date, summertime, coordinates, time zone, switching times and pin code must be set again.

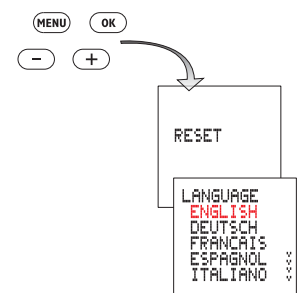



## 9 Control input with delaytime

The control signal affects only channel 1 and overrides all program settings for this channel (OR function). Channel 1 remains switched on as long as the control signal is present. **If the function CYCLE is selected under SETUP, channel 1 is switched on and off cyclically.** When the control signal is switched off, the output of channel 1 switches off after the defined delaytime, unless one of the programs for this channel specifies otherwise.

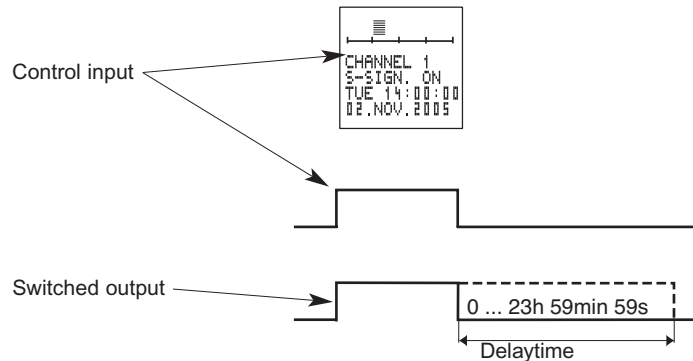

### Setting the delaytime

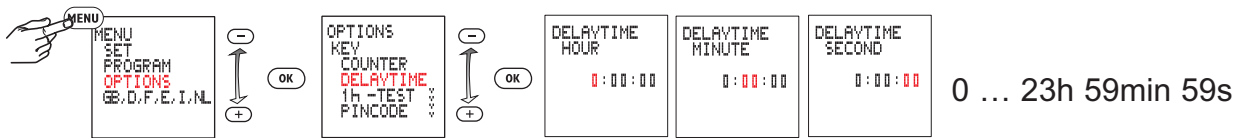

### Changing the lithium battery module

#### Important note:

If the battery is replaced with the supply voltage connected, all stored program data are retained. If the battery is replaced with the supply voltage disconnected, the date and time must be set again. **Notes for disposal of the lithium battery:** Dispose of the exhausted battery in accordance with your local regulations. Make sure the battery is fully discharged before disposal.

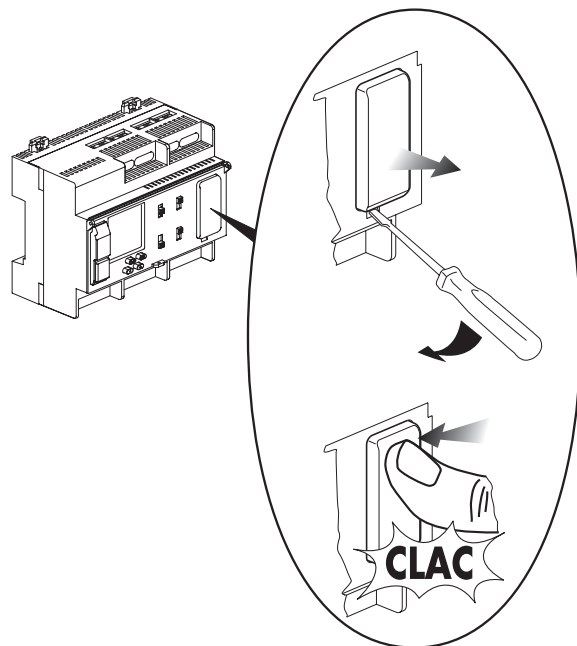

The data interface **KEY** is preset and cannot be changed.

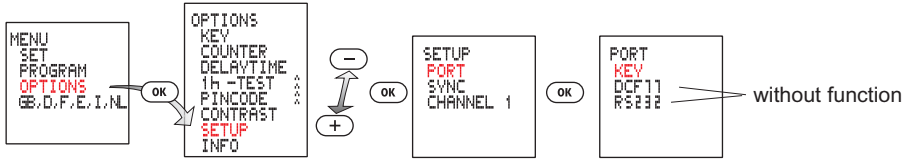

**Activating and deactivating mains synchronisation.**

The default setting is **PASSIVE**. In order to improve the accuracy, it is advisable to activate this synchronisation with the mains frequency (50/60 Hz).

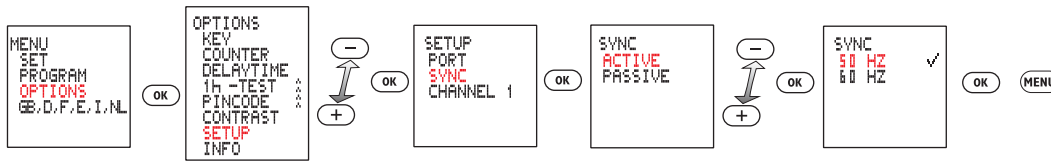

**Cycle function for channel 1**

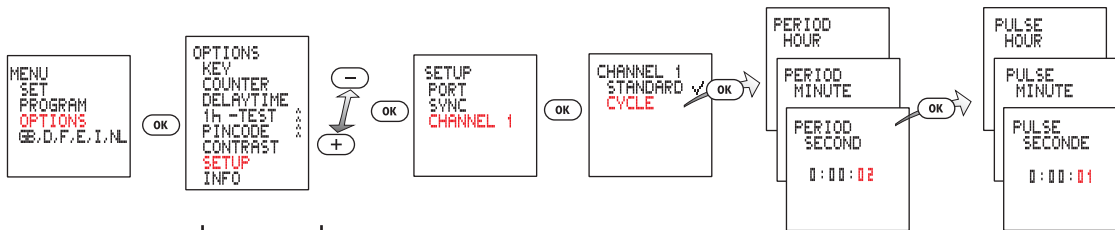

	min	max
PERIOD	2 s	2h
PULSE-TIME	1 s	1h 59min 59s

Instead of its **STANDARD** function, the output of channel 1 is switched on and off cyclically. The available parameters are the **PERIOD** and the **PULSE-TIME** within this period.

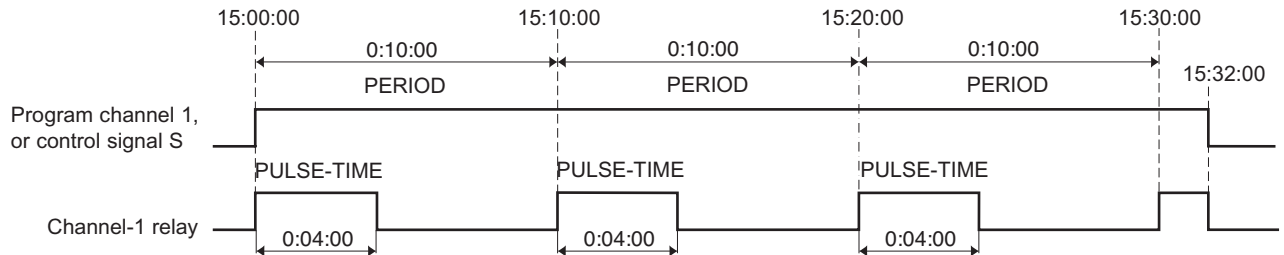

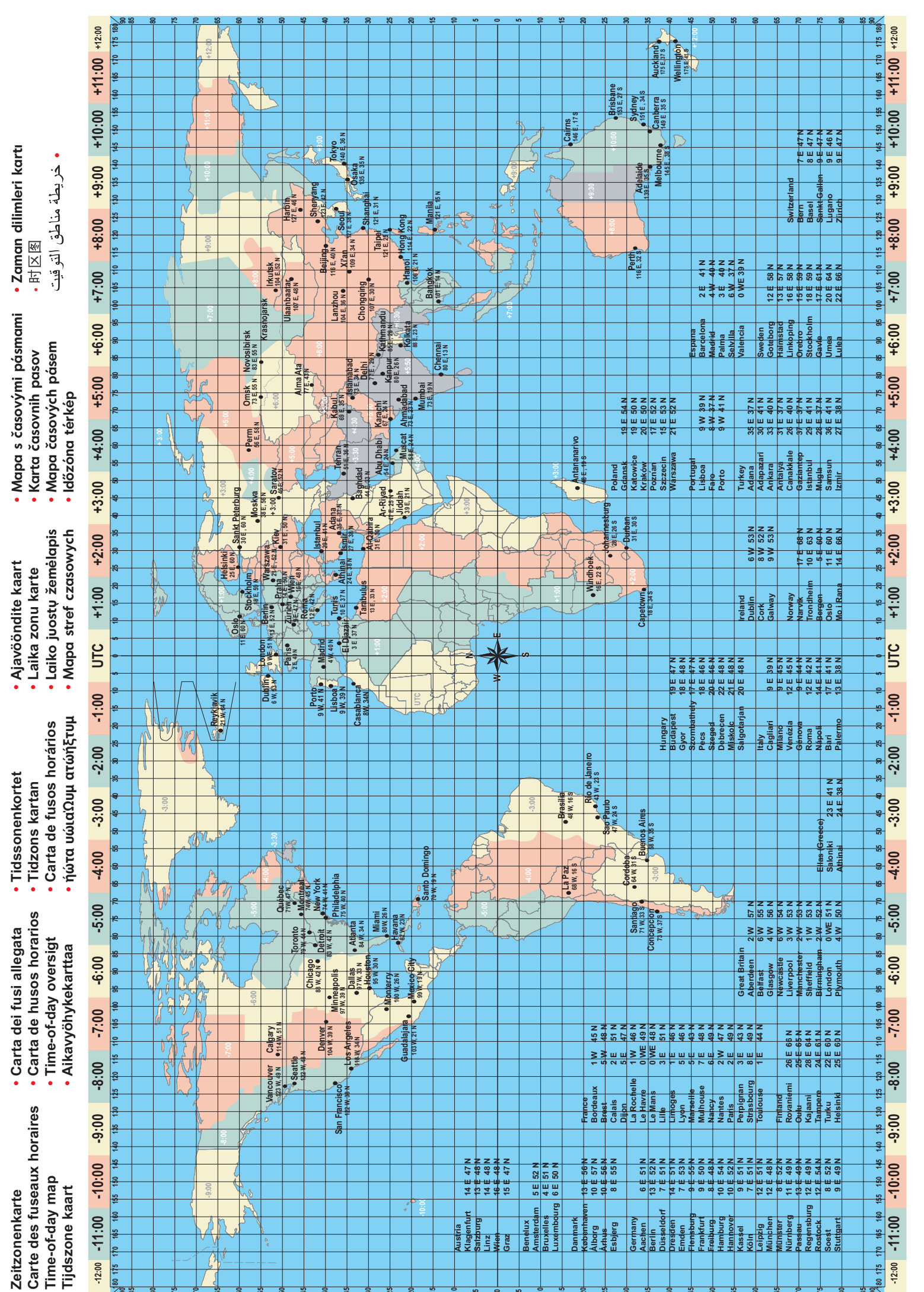

- Zeitzonekarte
- Carte des fuseaux horaires
- Time-of-day map
- Tidszone kaart
- Carta dei fusi allegata
- Carta de husos horarios
- Time-of-day oversigt
- Aikavyöhykekarttaa
- Tidssonenkortet
- Tidszonen kartan
- Carta de fusos horários
- ήώρα υπώριου αιώρηξιμυ
- Ajavöändite kaart
- Laika zonu karte
- Laiko juostų žemėlapis
- Mapa stref czasowych
- Tidszonenkortet
- Carta de husos horarios
- Time-of-day oversigt
- Aikavyöhykekarttaa
- Tidssonenkortet
- Tidszonen kartan
- Carta de fusos horários
- ήώρα υπώριου αιώρηξιμυ
- Ajavöändite kaart
- Laika zonu karte
- Laiko juostų žemėlapis
- Mapa stref czasowych
- Mapa s časovými pásmami
- Karta časovnih pasov
- Mapa časových pásem
- Időzóna térkép
- Zaman dilimleri kartı
- 时区图
- خريطة مناطق التوقيت

UTC -12:00 -11:00 -10:00 -9:00 -8:00 -7:00 -6:00 -5:00 -4:00 -3:00 -2:00 -1:00 UTC +1:00 +2:00 +3:00 +4:00 +5:00 +6:00 +7:00 +8:00 +9:00 +10:00 +11:00 +12:00