

A22NE-P

A22NE-PD

A22NE-P

A22E

Common Accessories and Tools

Common Note

Install in 22-dia. or 25-dia. Panel Cutout

(When Using a Ring)

- The small size of the control panel is realized by conserving space and changing the direction of the wiring.
- Since there is no looseness in the wiring, there is a reduction in the maintenance efforts.
- A lock lever mechanism that can be easily operated is adopted.
- A maximum of up to six contact points can be combined together in the contact-point configuration.
- Oil-resistant to IP65 (non-lighted models) / IP65 (lighted models) / Supports IP69K high-temperature, high-pressure cleaning (pull-reset models).



For the most recent information on models that have been certified for safety standards, refer to your OMRON website.

Be sure to read the "Safety Precautions" on pages 33 and 56.

Model Number Structure

Model Number Legend (Completely Assembled) Shipped as a set which includes the Operation Unit, LED Lamp (lighted model only), Mounting Latches, Lighting Units (lighted model only), and Switch Block.

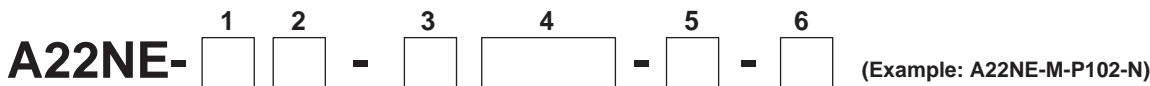

1. Operation Unit size (diameter)

| Code | Description |
|------|-------------|
| S | 30 dia. |
| M | 40 dia. |
| L | 60 dia. |

2. Reset function

| Code | Description |
|------|--------------|
| None | Turn-reset |
| P | Pull-reset * |

* The pull-reset type is only available on the 40 dia. Operation Unit, non-lighted type. Not available on lighted types.

3. Contact specification/Terminal specification

| Code | Description |
|------|---|
| P | Standard load/Push-in plus terminal block |

4. Contacts

| Code | Number of Switch Blocks | | Unit position | | | | | |
|------|-------------------------|----|---------------|-----|----|---------|---------------|----|
| | | | Non-lighted | | | Lighted | | |
| | NO | NC | 1 | 2 | 3 | 1 | 2 | 3 |
| 002 | 0 | 1 | --- | --- | NC | --- | Lighting unit | NC |
| 102 | 1 | 1 | NO | --- | NC | NO | Lighting unit | NC |
| 202 | 0 | 2 | NC | --- | NC | NC | Lighting unit | NC |
| 212 | 1 | 2 | NC | NO | NC | --- | | |
| 222 | 0 | 3 | NC | NC | NC | --- | | |

Note 1. NO: 1a-contact NC: 1b-contact
2. For details on the unit position, refer to the figure below.

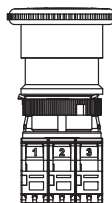

5. LED lamp voltage

| Code | Description | LED Lamp Voltage |
|------|-----------------|---------------------|
| N | Non-lighted | --- |
| A | Lighted (LED) * | 6 VAC/DC |
| B | | 12 VAC/DC |
| C | | 24 VAC/DC |
| D | | 100/110/120 VAC |
| E | | 200/220/230/240 VAC |

* Lighting color is red.

6. Others (Degree of Protection/Control box)

| Code | Configuration |
|------|----------------------|
| None | IP65 |
| 69K | IP69K |
| B * | Built-in control box |

* One-contact unit type.

A22NE-P

Ordering Information

List of Models (Completely Assembled)

Non-lighted Models

| Appearance | Operation | Degree of Protection | Contact configuration * | Set Model | Color of cap | |
|------------|--|---------------------------|---------------------------|---------------------------|----------------|----------------|
| | 40-dia. head Medium Pull-reset A22NE-MP-P□□2-N | IP65 oil-resistant models | 1NC (1) | A22NE-MP-P002-N | Red | |
| | | | 1NC, 1NO (2) | A22NE-MP-P102-N | | |
| | | | 2NC (2) | A22NE-MP-P202-N | | |
| | | | 2NC, 1NO (3) | A22NE-MP-P212-N | | |
| | | | 3NC (3) | A22NE-MP-P222-N | | |
| | 40-dia. head Medium Pull-reset A22NE-MP-P□□2-N-69K | IP69K | 1NC (1) | A22NE-MP-P002-N-69K | | |
| | | | 1NC, 1NO (2) | A22NE-MP-P102-N-69K | | |
| | | | 2NC (2) | A22NE-MP-P202-N-69K | | |
| | | | 2NC, 1NO (3) | A22NE-MP-P212-N-69K | | |
| | | | 3NC (3) | A22NE-MP-P222-N-69K | | |
| | 30-dia. head Small Turn-reset A22NE-S-P□□2-N | IP65 oil-resistant models | 1NC (1) | A22NE-S-P002-N | | |
| | | | 1NC, 1NO (2) | A22NE-S-P102-N | | |
| | | | 2NC (2) | A22NE-S-P202-N | | |
| | | | 2NC, 1NO (3) | A22NE-S-P212-N | | |
| | | | 3NC (3) | A22NE-S-P222-N | | |
| | 40-dia. head Medium Turn-reset A22NE-M-P□□2-N | | IP65 oil-resistant models | 1NC (1) | A22NE-M-P002-N | |
| | | | | 1NC, 1NO (2) | A22NE-M-P102-N | |
| | | | | 2NC (2) | A22NE-M-P202-N | |
| | | | | 2NC, 1NO (3) | A22NE-M-P212-N | |
| | | | | 3NC (3) | A22NE-M-P222-N | |
| | 60-dia. head Large Turn-reset A22NE-L-P□□2-N | | | IP65 oil-resistant models | 1NC (1) | A22NE-L-P002-N |
| | | | | | 1NC, 1NO (2) | A22NE-L-P102-N |
| | | | | | 2NC (2) | A22NE-L-P202-N |
| | | | | | 2NC, 1NO (3) | A22NE-L-P212-N |
| | | | | | 3NC (3) | A22NE-L-P222-N |

* The number in parentheses () indicates the number of switch units.

Lighted Model

| Appearance | Operation | Degree of Protection | Contact configuration * | LED lamp voltage | Set Model | Color of cap | | | | |
|------------|---|----------------------|-------------------------|------------------|----------------|--------------|----------------|-------------------|-------------------|----------------|
| | 40-dia. head Medium Turn-reset A22NE-M-P□□2-A | IP65 | 1NC (1) | 6 VAC/VDC | A22NE-M-P002-A | Red | | | | |
| | | | 1NC, 1NO (2) | | A22NE-M-P102-A | | | | | |
| | | | 2NC (2) | | A22NE-M-P202-A | | | | | |
| | 40-dia. head Medium Turn-reset A22NE-M-P□□2-B | | IP65 | 1NC (1) | 12 VAC/VDC | | A22NE-M-P002-B | | | |
| | | | | 1NC, 1NO (2) | | | A22NE-M-P102-B | | | |
| | | | | 2NC (2) | | | A22NE-M-P202-B | | | |
| | 40-dia. head Medium Turn-reset A22NE-M-P□□2-C | | | IP65 | 1NC (1) | | 24 VAC/VDC | A22NE-M-P002-C | | |
| | | | | | 1NC, 1NO (2) | | | A22NE-M-P102-C | | |
| | | | | | 2NC (2) | | | A22NE-M-P202-C | | |
| | 40-dia. head Medium Turn-reset A22NE-M-P□□2-D | | | | IP65 | | 1NC (1) | 100, 110, 120 VAC | A22NE-M-P002-D | |
| | | | | | | | 1NC, 1NO (2) | | A22NE-M-P102-D | |
| | | | | | | | 2NC (2) | | A22NE-M-P202-D | |
| | 40-dia. head Medium Turn-reset A22NE-M-P□□2-E | | | | | | IP65 | 1NC (1) | 220, 230, 240 VAC | A22NE-M-P002-E |
| | | | | | | | | 1NC, 1NO (2) | | A22NE-M-P102-E |
| | | | | | | | | 2NC (2) | | A22NE-M-P202-E |

* The number in parentheses () indicates the number of switch units.

Switch with Integrated Control Box

| Appearance | Contact configuration (Number of switch blocks) | Model |
|------------|---|------------------|
| | 1NC (1) | A22NE-M-P002-N-B |
| | 1NC, 1NO (2) | A22NE-M-P102-N-B |
| | 2NC (2) | A22NE-M-P202-N-B |

A22NE-PD

A22NE-P

A22E

Common Accessories and Tools

Common Note

Subassembled The Operation Unit, LED Lamp, Mounting Latches, Switch Blocks, and Lighting Unit can be ordered separately. Use them in combination for models that are not available as assembled Units. These can also be used as inventory for maintenance parts.

Non-lighted



Lighted

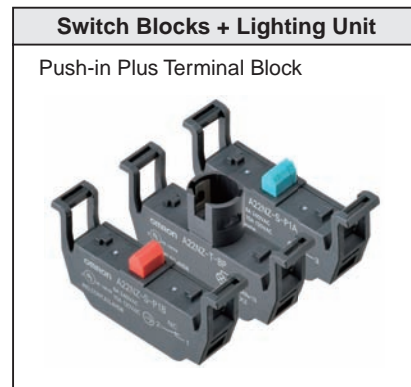
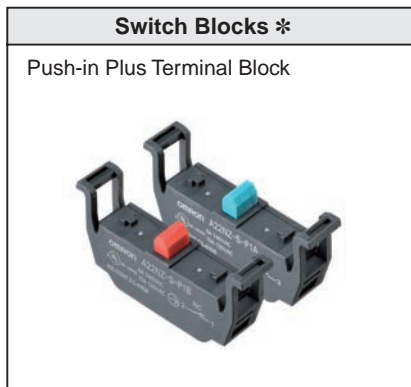
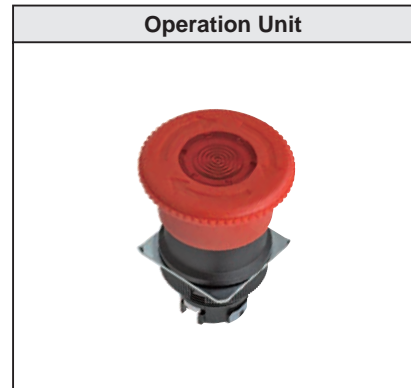

* Up to three Switch Blocks can be mounted.

A22NE-P

A22NE-PD







A22NE-P

A22E

Common Accessories and Tools

Common Note

Operation Unit Non-lighted

| Function | Sealing capability | Size | Single item order model | |
|------------|---------------------------|--|---|--|
| | | Small (30 dia.) | Medium (40 dia.) | Large (60-dia.) |
| Pull-reset | IP65 oil-resistant models | --- | A22NE-MP-N  | |
| | IP69K | --- | A22NE-MP-N-69K  | |
| Turn-reset | IP65 oil-resistant models | A22NE-S-N  | A22NE-M-N  | A22NE-L-N  |
| | | | A22NE-MRO-N A22NE-MRO-N-RD  | |
| | | | A22NE-MRS-N A22NE-MRS-N-RD  | |

Lighted





| Function | Sealing capability | Size | Single item order model |
|------------|--------------------|------------------|---|
| | | Medium (40 dia.) | |
| Turn-reset | IP65 | | A22NE-M-L  |

LED lamp

The LED lamps are exclusively for use with the A22N/M22N series, A22NE series and A30N series.

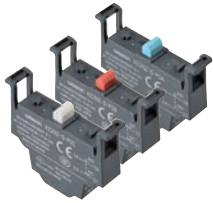
| Appearance | LED light | Rated voltage | Model | Remarks |
|---|-----------|------------------------|-------------------|--|
|  | Red | 6 VAC/VDC | A22NZ-L-RA | These LED lamps are for exclusive use with the A22N and the A22NE-P. These are provided with the completely assembled set of lighted models. Order LED lamps only when replacing them. |
| | | 12 VAC/VDC | A22NZ-L-RB | |
| | | 24 VAC/VDC | A22NZ-L-RC | |
| | | 100, 110, 120 VAC | A22NZ-L-RD | |
| | | 200, 220, 230, 240 VAC | A22NZ-L-RE | |

Accessories (Order Separately)

| Item | Appearance | Contact specifications | | Model | Remarks |
|---------------------------------|---|------------------------|---------------|----------------------|---|
| Switch Blocks (one contact) |  | 1NO (Blue) | Standard load | A22NZ-S-P1A | Provided as standard. Order Switch Blocks only when adding or replacing them. |
| | | 1NC (Red) | Standard load | A22NZ-S-P1B | |
| Switch Blocks (two contacts) |  | 2NO (Blue) | Standard load | A22NZ-S-P2A | Order Switch Blocks only when adding or replacing them. |
| | | 2NC (Red) | Standard load | A22NZ-S-P2B | |
| | | 1NO/1NC (White) | Standard load | A22NZ-S-P2C | |
| Lighting unit |  | 6 VAC/VDC | | A22NZ-T-AP | These are provided with the completely assembled set of lighted models. Order Lighting Units only when replacing them. |
| | | 12 VAC/VDC | | A22NZ-T-BP | |
| | | 24 VAC/VDC | | A22NZ-T-CP | |
| | | 100, 110, 120 VAC | | A22NZ-T-DP | |
| | | 200, 220, 230, 240 VAC | | A22NZ-T-EP | |
| Mounting Latches |  | --- | | A22NZ-H-02 | This Mounting Latch is for exclusive use with the A22NE-P. It is provided with the completely assembled set. Order Mounting Latches only when mounting Switch Blocks or Lighting Units that are purchased individually. |
| Control Boxes (Enclosures) |  | One hole, yellow box | | A22NZ-A-B101Y | Can be combined with 2-contact Switch Blocks. |
| | | | | A22NZ-A-B01Y | Cannot be combined with 2-contact Switch Blocks. * |

Note: For details on the accessories common to the screw terminal block types and push-in plus terminal block types, refer to "Common Accessories and Tools (Order Separately)" on page 51.

* The A22NZ-A-B101Y Control Box cannot be used in combination with the A22Z-3476-1 90-dia. Legend Plates for Emergency Stop or the A22Z-EG□ E-stop Shrouds.

A22NE-P

Specifications

Certified Standard Ratings

- UL508 (File No. E76675), CSA C22.2 No.14
6 A at 240 VAC, 10 A at 120 VAC
- TÜV (EN60947-5-1) - Certified direct opening -
(EN60947-5-5)
AC-15 3 A at 240 VAC
DC-13 4 A at 24 VDC
- CCC (GB/T14048.5)
AC-15 3 A at 240 VAC
DC-13 4 A at 24 VDC

Applicable Standards

UL1059, UL486E (Push-in Plus Terminal Block Types)

Note: Use a 10 A fuse type gI or gG that conforms to IEC60269 as a short-circuit protection device. This fuse is not provided in the main unit.

Ratings

Contacts (Standard Load)

| Rated insulation voltage (V) | Rated carry current (A) | Rated voltage (V) | Rated current (A) | | | |
|------------------------------|-------------------------|-------------------|-----------------------|-----------------------|-----------------------|-----------------------|
| | | | AC15 (Inductive load) | AC12 (Resistive load) | DC13 (Inductive load) | DC12 (Resistive load) |
| 600 | 10 | 24 VAC | 10 | 10 | --- | --- |
| | | 120 VAC | 6 | 10 | | |
| | | 240 VAC | 3 | 6 | | |
| | | 380 VAC | 1.9 | 2 | | |
| | | 440 VAC | 1.6 | 2 | | |
| | | 24 VDC | --- | --- | 4 | 8 |
| | | 120 VDC | | | 1.1 | 2.2 |
| | | 240 VDC | | | 0.55 | 1.1 |

- Note:** 1. The above ratings were obtained by conducting tests under the following conditions.
 (1) Ambient temperature: 20±2°C
 (2) Ambient humidity: 65±5%
 (3) Operating frequency: 20 operations/minute
2. Minimum applicable load: 10 mA at 5 VDC (Resistive load)
 The operating range may vary depending on the usage conditions and type of load.

Certified Standards

| Certification body | Standards | File No. |
|--------------------|---|--|
| UL * | UL508, C22.2 No.14 | E76675 |
| TÜV SÜD | EN60947-5-1 (Certified direct opening), EN60947-5-5 | Consult your OMRON representative for details. |
| CQC (CCC) | GB/T14048.5 | Consult your OMRON representative for details. |

Note: Only models with NC contacts have a direct opening mechanism.

* UL-certification for CSA C22.2 No. 14 has been obtained.

LED Lamp

| Rated voltage | Operating voltage | Current value |
|---------------|--------------------|---------------|
| 6 VAC/DC | 6 VAC/VDC ± 10% | Approx. 11 mA |
| 12 VAC/DC | 12 VAC/DC ± 10% | Approx. 12 mA |
| 24 VAC/DC | 24 VAC/DC ± 10% | Approx. 12 mA |
| 100 VAC | 100 VAC ± 10% | Approx. 12 mA |
| 110 VAC | 110 VAC ± 10% | |
| 120 VAC | 100 VAC to 130 VAC | |
| 200 VAC | 200 VAC ± 10% | Approx. 12 mA |
| 220 VAC | 220 VAC ± 10% | |
| 230 VAC | 230 VAC ± 10% | |
| 240 VAC | 220 VAC to 250 VAC | |

Characteristics

| Item | | Operation | Turn-reset | | Pull-reset | |
|---|--------------------------------------|--|-------------------|------------------------------|---|---------------------|
| | | | Non-lighted model | Lighted Model | Non-lighted model | |
| | | | A22NE-□-P□□□-N | A22NE-M-P□□□-□ | A22NE-MP-P□□□-N | A22NE-MP-P□□□-N-69K |
| Allowable operating frequency | Mechanical | 30 operations/minute or less (One operation consists of set and reset operations.) | | | | |
| | Electrical | 30 operations/minute or less (One operation consists of set and reset operations.) | | | | |
| Insulation resistance *1 | | 100 MΩ min. (at 500 VDC) | | | | |
| Contact resistance | | 100 mΩ max. (initial value) | | | | |
| Dielectric strength | Between terminals of same polarity*1 | 2,500 VAC, 50/60 Hz 1 minute (initial value) | | | | |
| | Between each terminal and ground | 2,500 VAC, 50/60 Hz 1 minute (initial value) | | | | |
| Vibration resistance | Malfunction | 10 to 55 Hz, 1.5 mm double amplitude (contact separation within 1 ms) | | | | |
| Shock resistance | Malfunction | 250 m/s ² max. (contact separation within 1 ms) | | | | |
| Durability | Mechanical | 300,000 operations min. (One operation consists of set and reset operations.) | | | 100,000 operations min. (One operation consists of set and reset operations.) | |
| | Electrical | 300,000 operations min. (One operation consists of set and reset operations.) | | | 100,000 operations min. (One operation consists of set and reset operations.) | |
| Ambient operating temperature *2 | | -20 to +70°C | -20 to +55°C | -20 to +70°C | -20 to +70°C *3 | |
| Ambient operating humidity | | 35 to 85% RH | | | | |
| Ambient storage temperature *2 | | -40 to +70°C | | | | |
| Degree of protection *4 | | IP65 oil-resistant models *5 | IP65 | IP65 oil-resistant models *5 | IP69K | |
| Electric shock protection class | | Class II | | | | |
| PTI (tracking characteristic) | | 175 | | | | |
| Degree of contamination | | 3 (EN 60947-5-1) | | | | |
| Minimum direct opening stroke | | 11 mm | | | | |
| Minimum direct opening force | | 45 N | | | | |
| Conditional short-circuit current | | 100 A (EN 60947-5-1) | | | | |
| Wight (for a 40-dia. head 1NC/1NO Operation Unit) | | Approx. 55g | Approx. 60g | Approx. 85 g | Approx. 115 g | |

*1. State when an LED is not added between terminals of the same polarity on a lighting unit. Does not apply to lighted-type 100 to 200 V lighting units.

*2. With no icing or condensation.

*3. Capable of operation at up to 80°C under IP□9K testing conditions per JIS D 5020.

*4. The degree of protection from the front of the panel.

*5. The degree of protection is IP65 even with an integrated control box, but the system is not oil resistant.

Operating Characteristics

| Item | Turn-reset | Pull-reset | |
|--------------------------|------------------------------|-------------------|---------------------------------------|
| | Lighted / non-lighted models | Non-lighted model | Non-lighted model (Models with IP69K) |
| Total travel force (TTF) | 45 N max. | 60 N max. | 70 N max. |
| Return force (RF) | 0.25N·m * max. | 60 N max. | 70 N max. |
| Total travel (TT) | 10 ±1 mm | 5.5 ±1 mm | 5.5 ±1 mm |

* Rotation torque value.

Terminal Arrangement (BOTTOM VIEW)

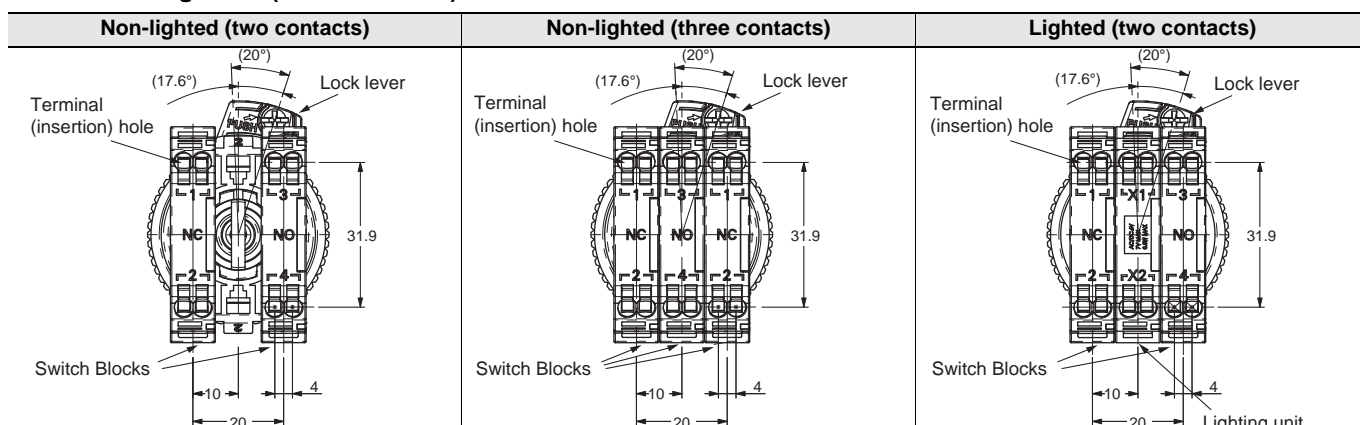

A22NE-P

A22NE-PD

Terminal connection

| Type | Terminal Connection (BOTTOM VIEW) | | | | | | | | | |
|-------------|-----------------------------------|---------------|--------------------|--------------|---------------------------|--------------|--------------|----------------------|--------------|--------------|
| | 1NC, 1NO (two contacts) | | 2NC (two contacts) | | 2NC, 1NO (three contacts) | | | 3NC (three contacts) | | |
| Non-lighted | NC 1 2 | NO 3 4 | NC 1 2 | NC 1 2 | NC 1 2 | NC 1 2 | NO 3 4 | NC 1 2 | NC 1 2 | NC 1 2 |
| Lighted | 1 2 | X1 X X2 | 3 4 | 1 2 | X1 X X2 | 1 2 | | | | |

Note: The above terminal connection diagrams are examples for 1NO, 1NC (two contacts), or 2NC (two contacts).

A22NE-P

Terminal wiring drawings of two-contact Switch Units

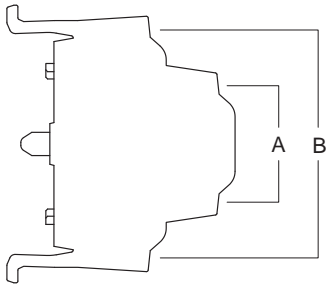

| Type | Terminal Connection (BOTTOM VIEW) | |
|------|-----------------------------------|-------------------------|
| | 2NC (two contacts) | 1NC, 1NO (two contacts) |
| A | 21 22 | 21 22 |
| B | 11 12 | 13 14 |

A22E

Structure and Nomenclature

Common Accessories and Tools

Common Note

Operation Unit
Color: Red
Non-lighted
LED lighting

Lamp
Light source
• LED Lamp

Switch
Mounting Latches
Switch Blocks
Lighting unit

Contact Ratings
6 A at 240 VAC
10 A at 120 VAC

Lighting Method
Non-lighted
Lighted (LED)

Dimensions

Non-lighted Models

A22NE-MP-P□□2-N

Pull-reset (40-dia.) Degree of Protection: IP65 oil-resistant models

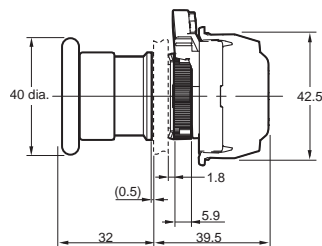
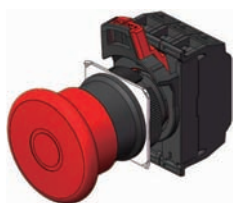

A22NE-MP-P□□2-N-69K

Pull-reset (40-dia.) Degree of Protection: IP69K

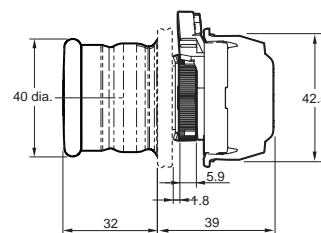
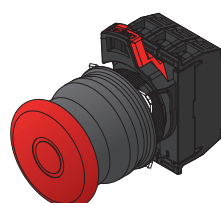

A22NE-S-P□□2-N

Small Turn-reset (30-dia.) Degree of Protection: IP65 oil-resistant models

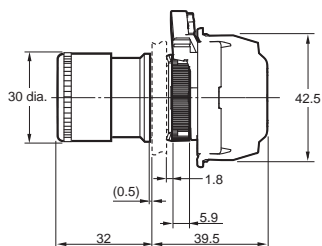
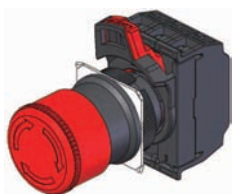

A22NE-M-P□□2-N

Medium Turn-reset (40-dia.) Degree of Protection: IP65 oil-resistant models

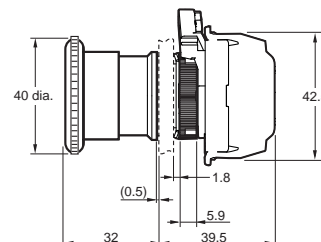
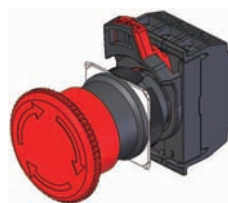

Note: The dimensions are the same even if the Operation Unit is replaced with the A22NE-MR□-N or the A22NE-MR□-N-RD.

A22NE-L-P□□2-N

Large Turn-reset (60-dia.) Degree of Protection: IP65 oil-resistant models

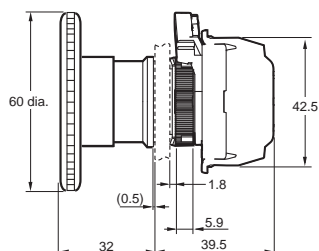
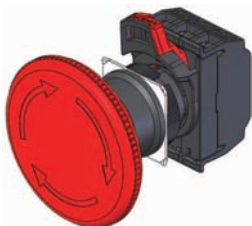

Lighted Model

A22NE-M-P□□2-□

Medium Turn-reset (40-dia.) Degree of Protection: IP65

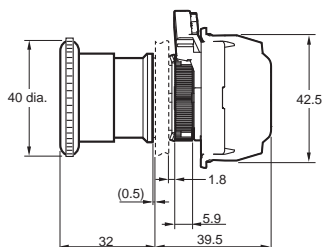
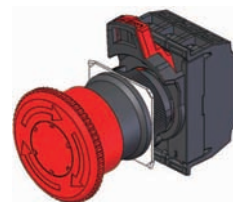

Dimensions when a two-contact Switch Block is attached

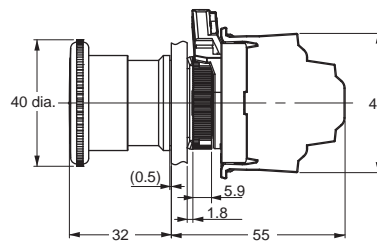

Note: Unless otherwise specified, a tolerance of ± 0.8 mm applies to all dimensions.

A22NE-PD

A22NE-P

A22E

Common Accessories and Tools

Common Note

A22NE-P

Accessories (Order Separately) Switch Block with Push-In Plus technology

Switch Block (one contact)

A22NZ-S-P1□

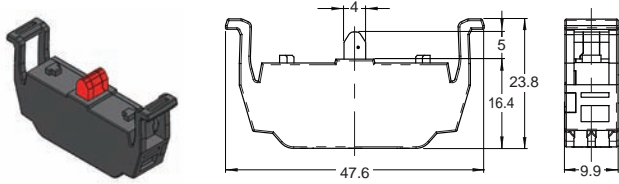

Switch Block (two contacts)

A22NZ-S-P2□

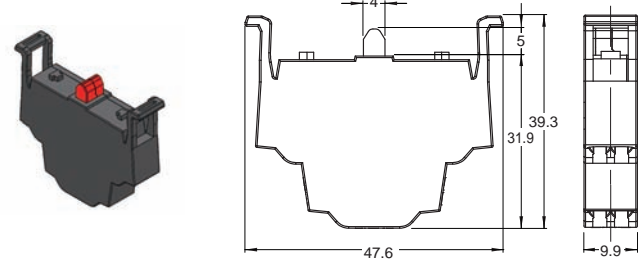

Lighting unit

A22NZ-T-□P

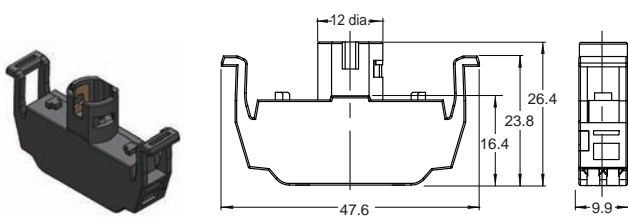

Mounting Latches

A22NZ-H-02

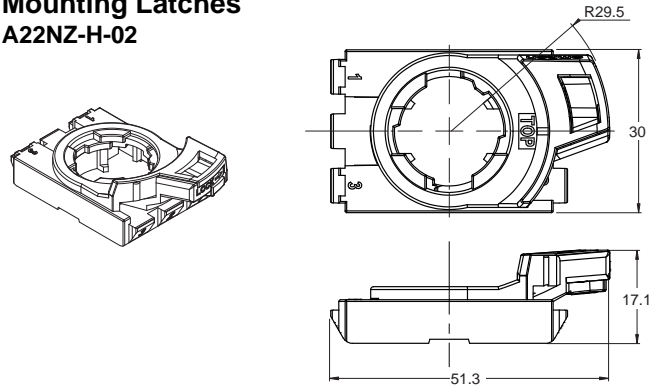

LED Lamp

A22NZ-L-□□

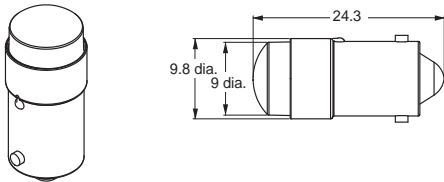

Control Box

A22NZ-A-B01Y

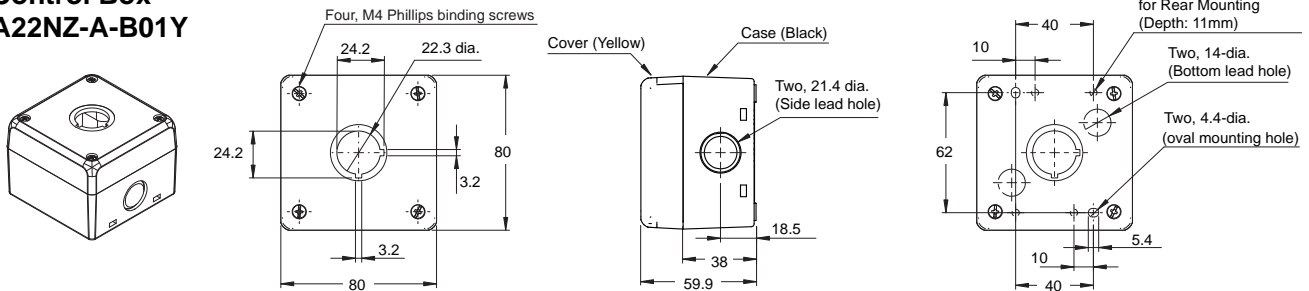

Control Box

A22NZ-A-B101Y

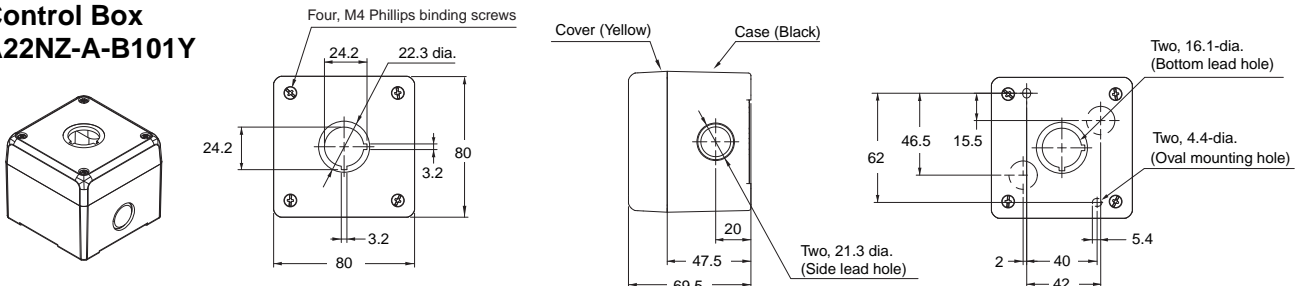

Note: For details on the accessories common to the screw terminal block types and push-in plus terminal block types, refer to "Common Accessories and Tools (Order Separately)" on page 51.

Application

Mounting to the Panel

(1) Preparing the Panel

Panel hole dimension and panel thickness

- If outer surface treatment such as coating is performed for the panel, the panel dimensions after outer surface treatment must meet the specified panel dimensions.

| Panel hole dimension | Panel thickness |
|----------------------|-----------------|
| 22.3 dia. | 1 to 5 mm |

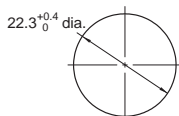

When using a A22Z-3360 (Order Separately) Lock Ring

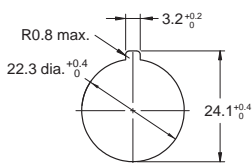

For 25-dia.

- Use the A22Z-R25 (Order Separately) rubber ring.
- * Switches with an IP69K degree of protection do not support the 25-dia.

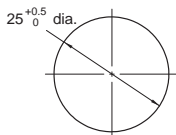

(2) Minimum mounting pitch (Dimension A, Dimension B)

Minimum mounting pitch

| Type of operation unit | Dimension A (mm) min. | Dimension B (mm) min. |
|-------------------------|-----------------------|-----------------------|
| 30-dia., 40-dia. models | 50 *1 | 50 |
| 60-dia. model | 70 | 70 |

- *1. If the Mounting Collar lock levers all face the same direction at the minimum mounting pitch, be sure to note the order the mounting collars are attached to the Operation Unit.
- *2. When using each accessory (Order Separately), set the A and B dimensions in view of the dimensions of the accessories.
- *3. Make sure the mounting pitch does not hinder the operation.

Panel Hole Dimensions for 22.3 Diameter

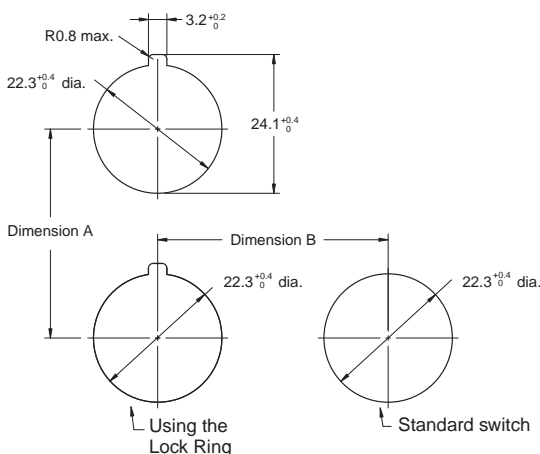

(3) Mounting the Operation Unit on the Panel

- Do not tighten the Tightening Nut more than necessary using tools such as pointed-nose pliers.
- Doing so will damage the Tightening Nut. (The tightening torque of the Tightening Nut is 1.0 to 2.0 N·m.) Tightening Wrench: A22Z-3905

Panel Hole of 22.3-mm Diameter

- Insert the Operation Unit from the front of the panel, insert the Lock Ring and Tightening Nut from the back of the panel, and tighten the Tightening Nut. Before tightening, check that the rubber washer is present between the Operation Unit and the panel.

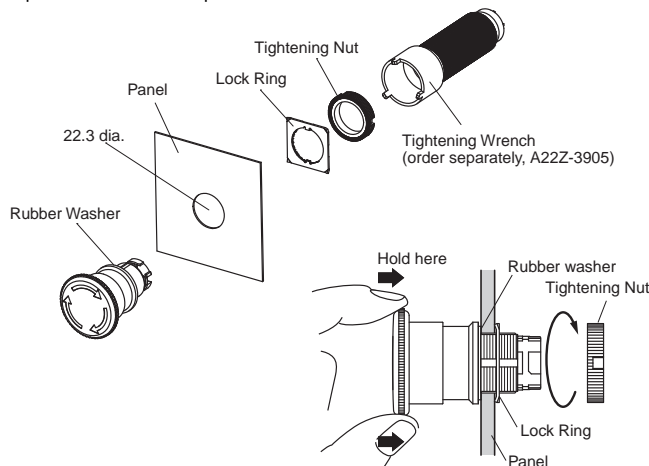

When the A22Z-3360 Lock Ring (Order Separately) is used

- Take note of the direction when mounting the Lock Ring.

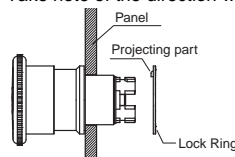

Panel Hole of 25-mm Diameter

- Insert the A22Z-R25 (Order Separately) between the Operation Unit and Panel, and tighten the Tightening Nut. Before tightening, check that the rubber washer supplied with the Operation Unit is present between the Operation Unit and the 25-dia. Ring.

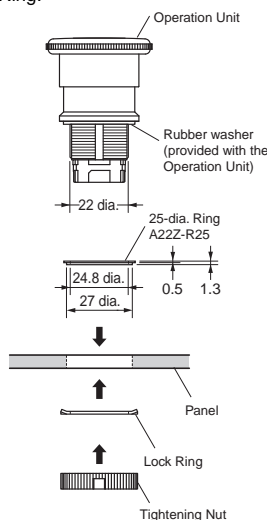

Panel Hole of 30-mm Diameter

- Insert the A22Z-A30 (Order Separately) between the Operation Unit and Panel, and tighten the Tightening Nut. Before tightening, check that the supplied rubber washer is present between the Operation Unit and the panel, and between the 30-dia. Resin Attachment and the panel.
- * Switches with an IP69K degree of protection do not support the 30-dia.

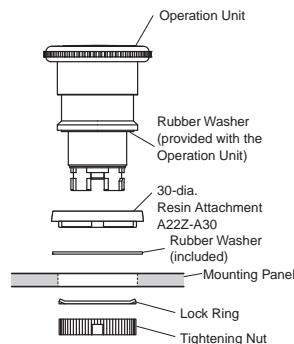

| Panel Cutouts | Panel thickness |
|---------------|-----------------|
| 25 mm dia. | 1 to 5 mm |
| 30 mm dia. | 1 to 3 mm |

A22NE-PD

A22NE-P

A22E

Common Accessories and Tools

Common Note

Removing the Mounting Latch

When the Mounting Latch is to be Removed

- Press the lock lever in from the back side to release the lock, and then hook the Mounting Collar with a screwdriver, move it in the direction indicated at (2), and remove it. Turn the lever all of the way until it clicks into place.

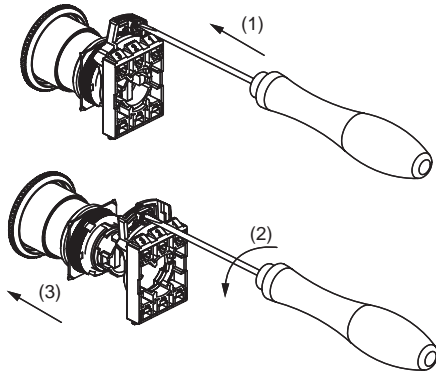

Switch Blocks and Lighting Unit

(1) Installing the Switch Blocks and Lighting Unit

- Catch the projection on the opposite side of the Mounting Collar from the lever side and press the Switch Block in the direction indicated at (1).

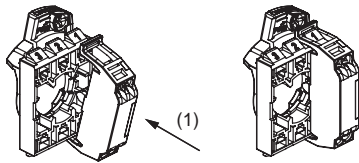

(2) Removing the Switch Blocks and Lighting Units

- Insert a screwdriver into the gap between the Mounting Collar and Switch Block and press it inward in the direction shown at (2).

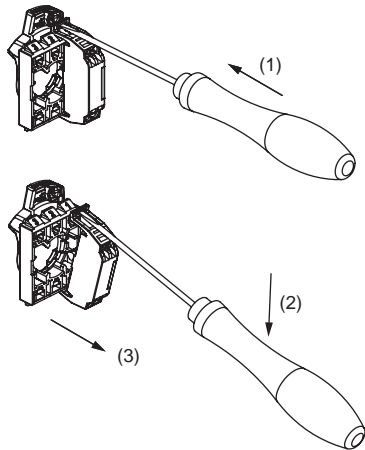

Attaching the LED Lamp to the Lighting Unit

When the LED Lamp is to be Installed

- Insert the protrusions on the LED Lamp into the guides on the Lighting Unit and then turn the LED Lamp in direction (2) to lock it in place.

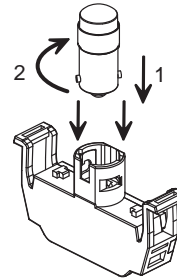

Control Box

(1) Mounting the Switch

Mount the Switch in the same way as for a standard panel.
The tightening torque of the Box screws is 1.4 to 2.0 N·m.

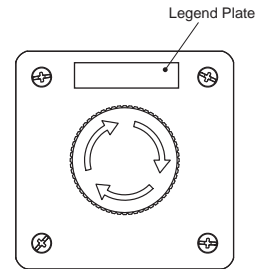

(2) Creating a Cable Hole

To open a cable hole, leave the cover attached, place the tip of a screwdriver in the grooves at four locations around the cable hole, and strike the screwdriver with a hammer to open the hole.

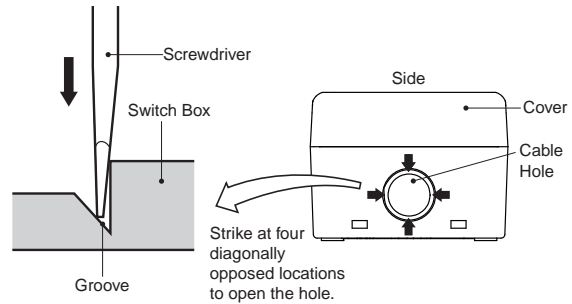

(3) Securing the Connector Cable

1. Insert the connector into the cable port hole in the Box and secure with the fixing ring inside the box.
2. Pass the tightening cap through the cable, insert the cable into the connector, and tighten the tightening cap to secure the cable.

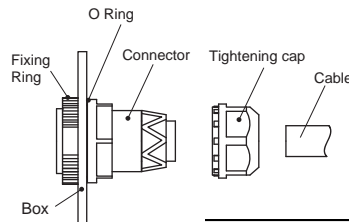

| Cable diameter (mm) | Connector |
|---------------------|-------------|
| 7 to 9 dia. | A22Z-3500-1 |
| 9 to 11 dia. | A22Z-3500-2 |

Safety Precautions

Be sure to read the precautions for **All PushButton Switches** in the website at: <http://www.ia.omron.com/>.

Indication and Meaning for Safe Use

| | |
|--|---|
|  Warning | Indicates a potentially hazardous situation that, if not avoided, could result in serious injury or death. Additionally there may be significant property damage. |
| Precautions for Safe Use | Comments on what to do or avoid doing, to use the product safely. |
| Precautions for Correct Use | Supplementary comments on what to do or avoid doing to use the product safely and prevent its malfunctioning or an adverse effect on its performance or functions. |

 **WARNING**

Do not perform wiring with power supplied to the Switch/Indicator. Do not touch the terminals or other charged parts while power is being supplied. Doing so may result in electric shock.



Precautions for Safe Use

- If the Operation Unit is separated from the Switch Units, the equipment will not stop, resulting in a hazardous situation. Make sure the Operation Unit, Mounting Latches, and the Switch Units are properly assembled.

<Assembling the Operation Unit and the Mounting Latches>
Align the TOP indication (the  mark) on the Operation Unit with the TOP indication on the Mounting Latches to fit it properly, and turn the lock lever on the Mounting Latch in the direction shown in the figure below until a clicking sound is heard.

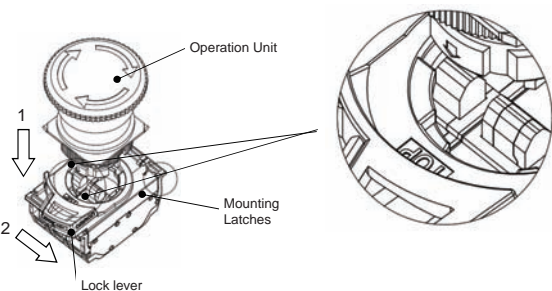

<Assembling the Mounting Latches and Switch Blocks>
Make sure the hooking part (convex part) on the Mounting Latches is perfectly latched into the hooking part (concave part) on the Switch Block.

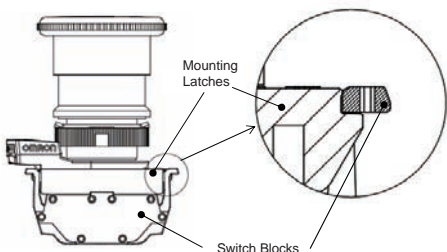

- When transition wiring is performed, make sure the switching current inside the Switch and the current based on the transition wiring is below the rated current of the Switch. If a current value higher than the rated current flows, it could result in emission of heat, or damage and deformation of the Switch, which could cause fire and locking of the contact, and thus a loss of safety.
- Do not disassemble or modify the Switch/Indicator under any circumstances.

- Doing so may prevent the Switch/Indicator from functioning to its full capability. Do not drop the Switch/Indicator. Do not apply pressure that may deform or alter the Switch/Indicator.
- The durability of the Switch varies considerably depending on the switching conditions. Always test the Switch/Indicator under actual working conditions before application and use the Switch/Indicator only for the number of switching operations allowed.
- Do not allow the load voltage and current to exceed the rated value. This may damage or burn out the Switch/Indicator.
- Do not use the Switch/Indicator in locations where explosive or flammable gases or liquid may be present or scattered. The electric arc or the heat caused by switching contacts may cause a fire or explosion.
- Do not use the Switch/Indicator in locations where toxic gases, such as H₂S, SO₂, NH₃, HNO₃, and Cl₂, may be present, or in locations subject to high temperature or humidity. Doing so may damage the Switch/Indicator due to contact failure or corrosion.
- Do not use the Switch/Indicator submerged in oil or water, or in locations continuously subject to splashes of oil or water. Doing so may result in oil or water entering and damaging the Switch/Indicator.
- Do not use or keep the Switch/Indicator under the following conditions:
 - Subject to severe temperature changes.
 - Subject to high humidity or condensation.
 - Subject to severe vibration or shock.
 - Where direct rays of the sun strike.
 - Where sea breeze may be present.
- Make sure that a rubber washer is present between the Operation Unit and the panel. In models with IP69K, make sure the rubber bush of the Operation Unit is properly attached. Otherwise, the specifications of the protective structure may not be satisfied.
- Do not apply excessive force to the Switch or wirings. Damage or deformation of the Switch Block could cause an improper contact or a loss of safety.
- Use an appropriate wiring and crimp terminals (hereinafter, called ferrule terminals).
- Exercise caution to avoid wiring errors when connecting the terminals.
- To prevent wiring materials from smoking or ignition, confirm wire ratings and use the wiring materials given in the following table.

| Wire Type | Wire material | Recommended Wire | Wire coating peeling amount |
|------------------------------|---------------|---|---|
| Solid wire/ Stranded Wire | Copper | 0.25 to 1.5 mm ² AWG 24 to 16 | Ferrules used: 10 to 12 mm (Varies depending on the recommended ferrule conductor length) Ferrules not used: 8 mm |

Use wiring crimp terminals and ferrule terminals of the specified size.

- After storing the product for a long time exceeding 1 year, perform, at a minimum, inspections of the operating characteristics, contact resistance, insulation resistance, and dielectric strength as well as evaluate the product under the working conditions.
- This Switch/Indicator is intended for indoor use only. Using the Switch/Indicator outdoors may result in failure.
- Do not wire anything to the release holes.
- Do not tilt or twist a flat-blade screwdriver while it is inserted into a release hole on the terminal block. The terminal block may be damaged.
- Insert a flat-blade screwdriver into the release holes at an angle. The terminal block may be damaged if you insert the screwdriver straight in.
- Do not allow the flat-blade screwdriver to fall out while it is inserted into a release hole.
- Do not bend a wire past its natural bending radius or pull on it with excessive force. Doing so may cause the wire disconnection.

A22NE-PD

A22NE-P

A22E

Common Accessories and Tools

Common Note

- Do not insert more than one wire into each terminal insertion hole.
- Do not mount A22N-P or A22NE-P Push-In Plus terminal switch blocks on A22N screw terminal blocks. Doing so may result in unsatisfactory performance.
- When mounting on a device with high airtightness, test operation in advance. There is a risk that the negative pressure will prevent the Operation Unit of from returning.
- In the case of loads where an inrush current occurs when the contact is opened or closed, the durability may reduce due to extreme wear on the contacts.
If necessary, insert a contact protection circuit.

Precautions for Correct Use

Wiring

1. Connecting Wires to the Push-In Plus Terminal Block

Part Names of the Terminal Block

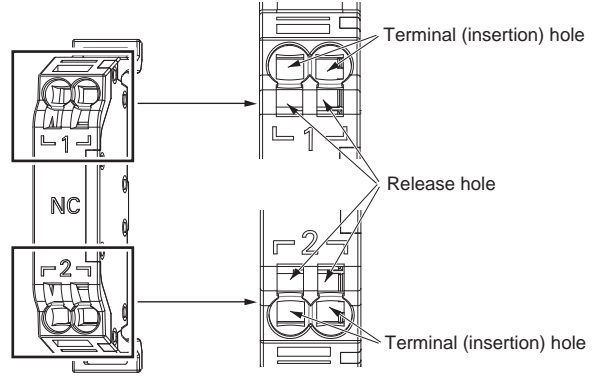

Connecting Wires with Ferrules and Solid Wires

- Insert the solid wire or ferrule straight into the terminal block until the end strikes the terminal block. The angle should be approximately 6°.
- If a wire is difficult to connect because it is too thin, use a flat-blade screwdriver in the same way as when connecting stranded wires.

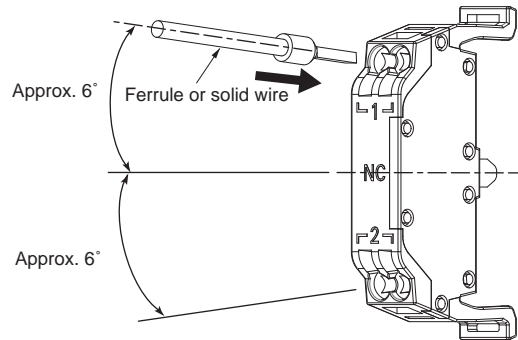

The wiring for the Lighting Unit and Switch Block (2 contacts) are the same as for the Switch Block (1 contact) shown in the above illustration.

Connecting Stranded Wires

Use the following procedure to connect the wires to the terminal block.

1. Hold a flat-blade screwdriver at an angle and insert it into the release hole.
The angle should be approximately 6°. If the flat-blade screwdriver is inserted correctly, you will feel the spring in the release hole.
2. With the flat-blade screwdriver still inserted into the release hole, insert the wire into the terminal hole until the end strikes the terminal block.
3. Remove the flat-blade screwdriver from the release hole.

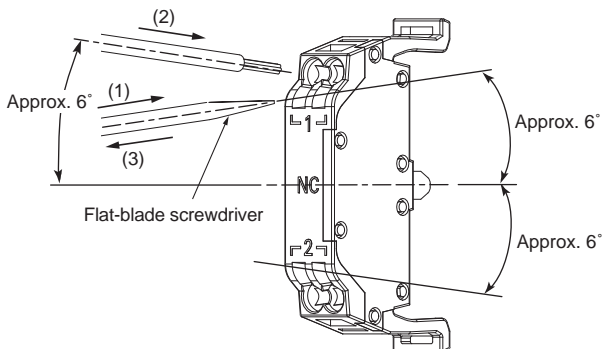

The wiring and screwdriver angles for the Lighting Unit and Switch Block (2 contacts) are the same as for the Switch Block (1 contact) shown in the above illustration.

Checking Connections

- After the insertion, pull gently on the wire to make sure that it will not come off and it is securely fastened to the terminal block.
- If you use a ferrule with a conductor length of 10 mm, part of the conductor may be visible after the ferrule is inserted into the terminal block, but the product insulation distance will still be satisfied.

2. Removing Wires from the Push-In Plus Terminal Block

Use the following procedure to remove wires from the terminal block. The same method is used to remove stranded wires, solid wires, and ferrules.

1. Hold a flat-blade screwdriver at an angle and insert it into the release hole. The angle should be approximately 6°.
2. With the flat-blade screwdriver still inserted into the release hole, remove the wire from the terminal insertion hole.
3. Remove the flat-blade screwdriver from the release hole.

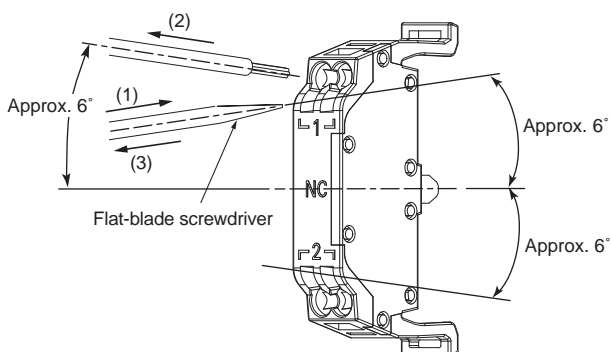

The wiring and screwdriver angles for the Lighting Unit and Switch Block (2 contacts) are the same as for the Switch Block (1 contact) shown in the above illustration.

3. Recommended Ferrules and Crimp Tools
Coating peeling amount

| Recommend Wire Type | Stripping length (Ferrules not used) |
|---|--------------------------------------|
| 0.25 to 1.5 mm ² /AWG 24 to AWG 16 | 8 mm |

Recommended ferrules

| Applicable wire | | Ferrule conductor length (mm) | Stripping length (mm) (Ferrules not used) | Recommended ferrules | | |
|-------------------------|-------|-------------------------------|---|--|--------------------|--------------|
| (mm ²) | (AWG) | | | Phoenix Contact product | Weidmuller product | Wago product |
| 0.25 | 24 | 8 | 10 | AI 0, 25-8 | H0.25/12 | 216-301 |
| | | 10 | 12 | AI 0, 25-10 | --- | --- |
| 0.34 | 22 | 8 | 10 | AI 0, 34-8 | H0.34/12 | 216-302 |
| | | 10 | 12 | AI 0, 34-10 | --- | --- |
| 0.5 | 20 | 8 | 10 | AI 0, 5-8 | H0.5/14 | 216-201 |
| | | 10 | 12 | AI 0, 5-10 | H0.5/16 | 216-241 |
| 0.75 | 18 | 8 | 10 | AI 0, 75-8 | H0.75/14 | 216-202 |
| | | 10 | 12 | AI 0, 75-10 | H0.75/16 | 216-242 |
| 1/1.25 | 18/17 | 8 | 10 | AI 1-8 | H1.0/14 | 216-203 |
| | | 10 | 12 | AI 1-10 | H1.0/16 | 216-243 |
| 1.25/1.5 | 17/16 | 8 | 10 | AI 1, 5-8 | H1.5/14 | 216-204 |
| | | 10 | 12 | AI 1, 5-10 | H1.5/16 | 216-244 |
| Recommended Crimp Tools | | | | CRIMPFOX6 CRIMPFOX6T-F CRIMPFOX10S | PZ6 roto | Variocri mp4 |

- Note:**
1. Make sure that the outer diameter of the wire coating is smaller than the inner diameter of the insulation sleeve of the recommended ferrule.
 2. Make sure that the ferrule processing dimensions conform to the following figures.

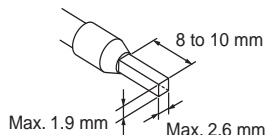

Recommended Flat-Blade Screwdrivers

Use a flat-blade screwdriver to connect and remove wires. Use one of the following flat-blade screwdrivers. The following table shows manufacturers and models as of 2015/Dec.

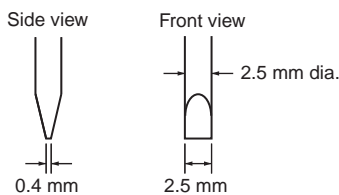

| Model | Manufacture |
|------------------------------------|-----------------|
| ESD 0,40 x 2,5 | Wera |
| SZS 0,4 x 2,5 SZF 0-0,4 x 2,5 * | Phoenix Contact |
| 0,4 x 2,5 x 75 302 | Wiha |
| AEF.2,5 x 75 | Facom |
| 210-719 | Wago |
| SDI 0,4 x 2,5 x 75 | Weidmuller |

* The SZF 0-0,4 x 2,5 (manufactured by Phoenix Contact) can be procured through an OMRON exclusive purchase form (XW4Z-00B).

- After wiring the Switch/Indicator, provide a sufficient insulation distance.

LED Lamps

- A current-limiting resistor is built in the LED lamp, so the installation of an external resistance is not required.
- Lighting malfunction of the LED lamp
A micro-current of approximately 0.1 mA or less is sufficient to turn on the LED lamps. Take a countermeasure like adding a resistor to prevent mis-lighting in parallel to the LED lamp.
The micro-current varies with the machine (leak current or stray capacity between cables, etc.). Select resistance value and allowable power consumption that meet the actual current.

(Example of lighting malfunction prevention circuit)

When using a 24-VAC/VDC lighted unit

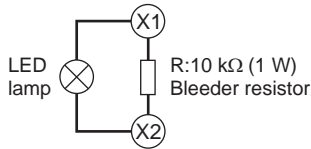

Be sure to read the "Safety Precautions" on page 56.