

## 1-1 Applicable Units

A Host Link Unit allows a host computer to monitor the operating status and data areas of the PCs and to control the communications between the PCs and the controlled system.

One Host Link Unit is required for each PC, and up to 32 PCs can be connected to a single host computer. The Host Link Units described in this manual are referred to as “Rack-mounting” or “CPU mounting.” A Rack-mounting Host Link Unit is mounted to an I/O slot of the CPU or Expansion I/O Rack of the building block PC. A CPU-mounting Host Link Unit is mounted directly to the PC’s CPU.

Different types of Host Link Units, e.g., Rack-mounting and CPU-mounting, can be combined so that the same PC can be connected to more than one Host Link Unit. An example of a system using some of these combinations is provided in *1-2 System Configuration*, along with other example configurations. Most of these systems also employ Link Adapters, which are usually used in a system to branch between Host Link Units, host computers, etc., or to interface wire cables with optical fiber cables, or to perform both of these functions.

The following table gives the mounting method, types of connectors, and applicable PCs for each of the Host Link Units dealt with in this manual.

Host Link Unit	Mounting Type	Applicable PCs	Connection*
C200H-LK101-PV1***	Rack-mounting	C200H, C200HS, C200HX, C200HG, and C200HE****	APF/PCF/H-PCF
C200H-LK201-V1***	Rack-mounting	C200H, C200HS, C200HX, C200HG, and C200HE****	RS-232C
C200H-LK202-V1***	Rack-mounting	C200H, C200HS, C200HX, C200HG, and C200HE****	RS-422
3G2A5-LK101-PEV1	Rack-mounting	C500, C1000H, and C2000H	APF/PCF/H-PCF
C500-LK103-P**	Rack-mounting	C500, C1000H, and C2000H	APF/PCF/H-PCF
3G2A5-LK101-EV1	Rack-mounting	C500, C1000H, and C2000H	PCF/H-PCF
3G2A5-LK201-EV1	Rack-mounting	C500, C1000H, and C2000H	RS-232C/RS-422
C500-LK103**	Rack-mounting	C500, C1000H, and C2000H	PCF/H-PCF
C500-LK203**	Rack-mounting	C500, C1000H, and C2000H	RS-232C/RS-422
3G2A6-LK101-PEV1	CPU-mounting	C□□H (V1 models), C200H, C120, C500, C1000H, and C2000H	APF/PCF/H-PCF
3G2A6-LK101-EV1	CPU-mounting	C□□H (V1 models), C200H, C120, C500, C1000H, and C2000H	PCF/H-PCF
3G2A6-LK201-EV1	CPU-mounting	C□□H (V1 models), C200H, C120, C500, C1000H, and C2000H	RS-232C
3G2A6-LK202-EV1	CPU-mounting	C□□H (V1 models), C200H, C120, C500, C1000H, and C2000H	RS-422

\* APF: All-plastic optical fiber cable/PCF: Plastic-clad optical fiber cable/H-PCF: Hard-clad plastic optical fiber cable/RS-422: RS-422 cable/RS-232C: RS-232C cable

\*\* The C500-LK103(-P) and C500-LK203 can be used with the C500 PC only when the 3G2C3-CPU11-EV1 is used.

\*\*\* Reading or writing words in the portion of the EM area expanded by the C200HX/C200HG/C200HE is not possible.

\*\*\*\* C200H Rack-mounting Host Link Units cannot be used with C200HX/HG/HE “-Z-type” PCs or CS1-series PCs.

## 1-2 System Configuration

The following examples illustrate possible applications of Host Link Units in wired or optical systems, or both.

Some systems will comprise just one Host Link Unit connected to a single host computer. This is known as a “single-link” system. Others systems might comprise many Host Link Units connected to a host computer. This configuration is known as a “multiple-link” system. Although most systems will require only one

host computer, if both Rack-mounting and CPU-mounting Host Link Units are used together, two host computers can be connected to the same PC, independent of each other. The PC can then execute commands sent from either host computer.

Up to two of the C500-LK103, C500-LK103-P, and C500-LK203 Rack-mounting Host Link Units can also be connected, in any combination (including two of the same Units), to any to a single C1000H, or C2000H PC, allowing up to three host computers to be connected to these PCs. Control from three host computers is also available with C200H/HS/HX/HG/HE PCs, where a second Rack-mounting Host Link Unit can be added on a C200H Expansion I/O Rack. All other PCs are limited to two Host Link Units. SYSMAC NET Link Units can be combined with the C500-LK103(-P) and C500-LK203 Rack-mounting Host Link Units when a C1000H or C2000H PC is used. When combining with a SYSMAC NET Link Unit, however, only one Rack-mounting Host Link Unit can be used instead of two.

In all but the third configuration example, Link Adapters are used to branch between system devices, or to convert between different types of cables, or to perform both of these functions. The first part of the Link Adapter model numbers (3G2A9-) in the examples has been omitted.

## 1-2-1 Connections

System components can be connected using RS-232C or RS-422 cables, or both, any of three types of optical fiber cable, or a combination of wired and optical sections. In any system, the maximum length of RS-232C cable is 15 m. The total length of all RS-422 cable must be no longer than 10 m. RS-232C and RS-422 cables which are used to connect the Host Link Unit to the host computer are not available from OMRON and must be purchased from an alternative source.

Maximum lengths for optical fiber cables are determined by the type of cable and the particular models employed. Models which finish with “-P” in the code number can be set at a length of 20 m for APF cable and 200 m for PCF cable. Models without the “-P” coding can be set at a maximum length of 800m with PCF cable.

## 1-2-2 System Examples

### Example 1

### Serial Multiple-link System with Optical Fiber Cable

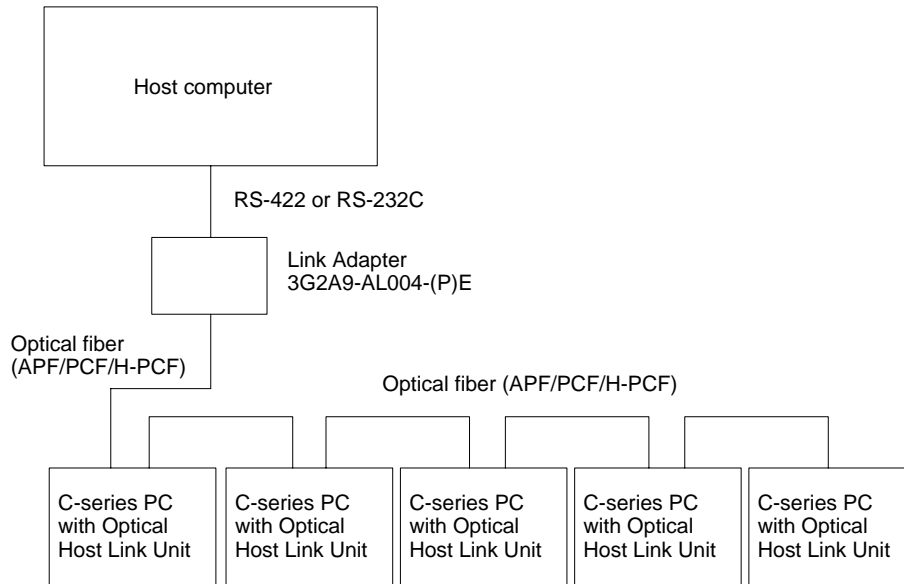

As shown above, more than one Host Link Unit can be connected in series using optical fiber. If, however, any failure (due to power failure, disconnection, etc.) occurs in one of the Units, the series connection will cause all subsequent Host Link Units to cease to operate. This can be prevented by using Link Adapters such as the 3G2A9-AL002-PE Link Adapter shown in the following example. These Link Adapters bypass any Host Link Unit not connected properly so that the rest of the system can operate normally.

**Example 2**

Parallel Multiple-link System with Optical Fiber Cable

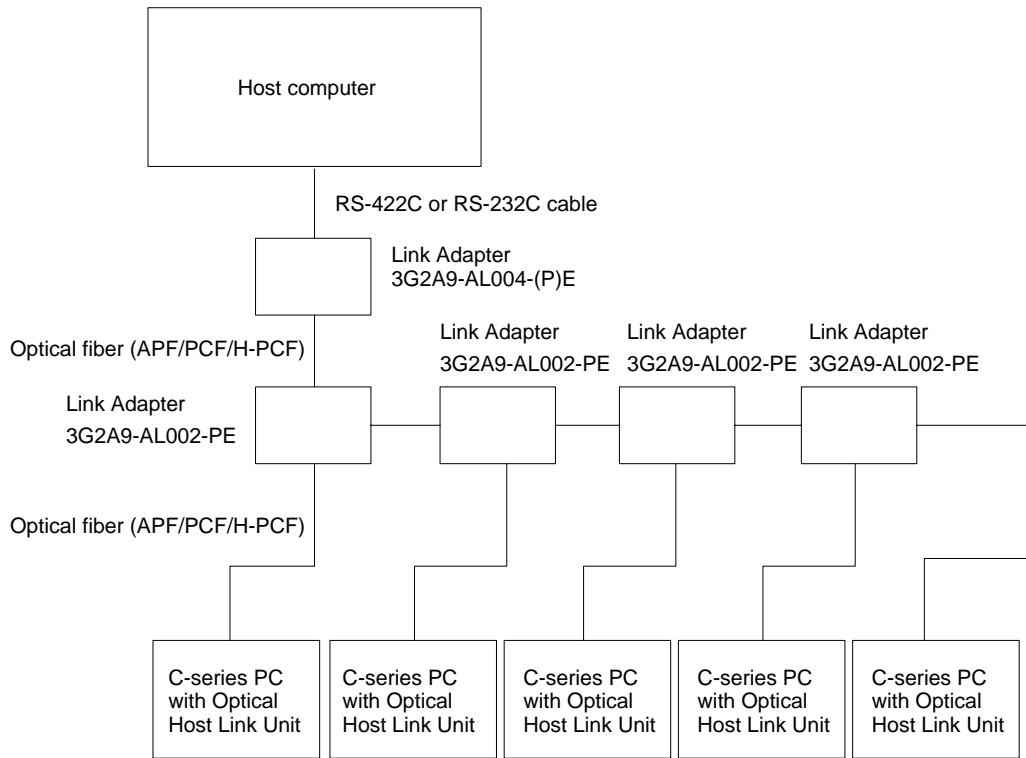

Even if a power failure occurs in a Host Link Unit connected to a branch line of a Link Adapter, signals are still transmitted to the other Host Link Units.

**Example 3**

Single-link System with RS-232C Cable

In a system where a RS-232C cable connects a Host Link Unit directly to a host computer, only one Host Link Unit can be connected to that host computer, i.e., it has a single-link. The following Host Link Units can be used in this type of system: 3G2A5-LK201-EV1, C200H-LK201-V1, C500-LK203, and 3G2A6-LK201-EV1. It should be noted that the PC onto which the Host Link Unit is mounted could have another Host Link Unit connected directly or indirectly connected to another host computer.

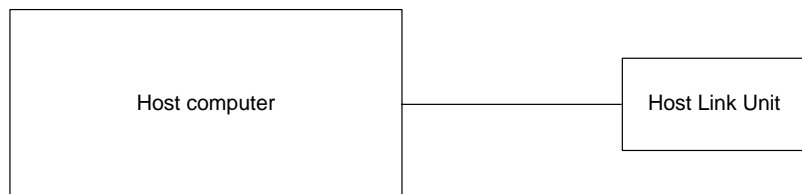

**Example 4**

**Multiple-link System with RS-232C and RS-422 Cable**

By using RS-422 cable, more than one Host Link Unit can be connected to the same host computer to make a multiple-link system.

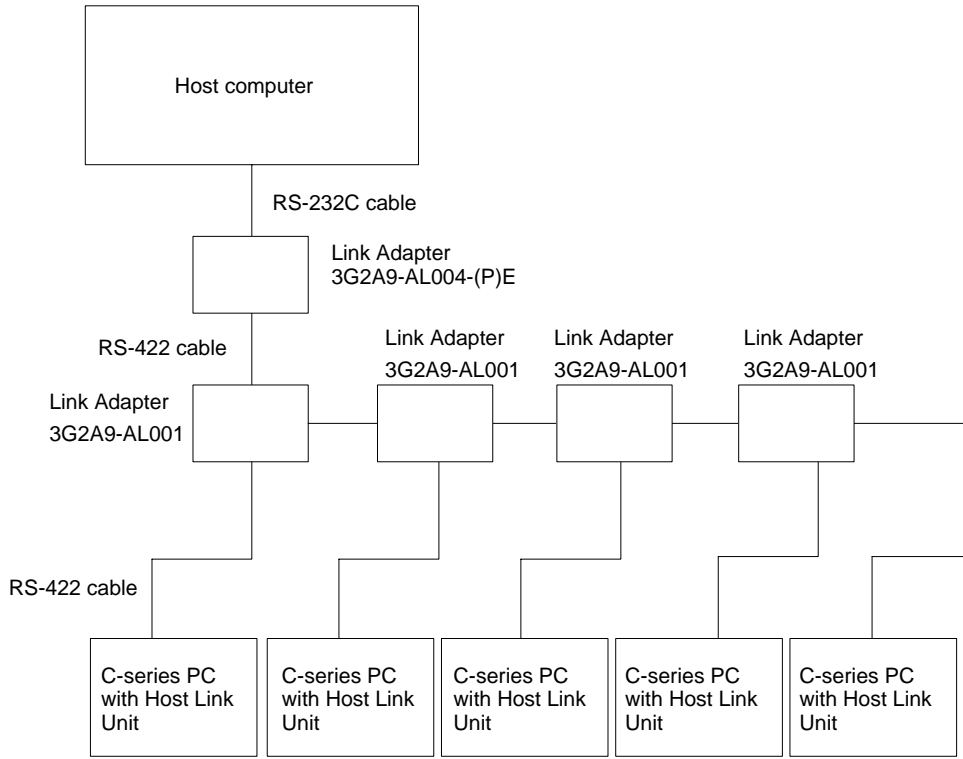

**Example 5**

**Multiple-link Multiple-level System**

In this example, Rack-mounting and CPU-mounting Host Link Units are combined to control a C500 PC from two host computers. A CPU-mounting Host Link Unit is also combined with two Rack-mounting Host Link Units (C500-LK103(-P) or C500-LK203, or both) on another PC, a C1000H or C2000H, to control this PC from all three host computers. Furthermore, two C200H Rack-mounting Host Link Units (C200H-LK101-PV1 or C200H-LK202-V1, or both) are combined to control a C200H/HS/HX/HG/HE PC from a third host computer.

All lines connecting to host computers would have to be RS-232C cable. All other lines could be RS-422 cable or optical fiber cable, depending on the particular Host Link Units and Link Adapters used. Note that the host computer on the upper right is considered to be in a single-link system with the Host Link Unit directly beneath it, despite the fact that other Host Link Units connect the same PC to other host computers.

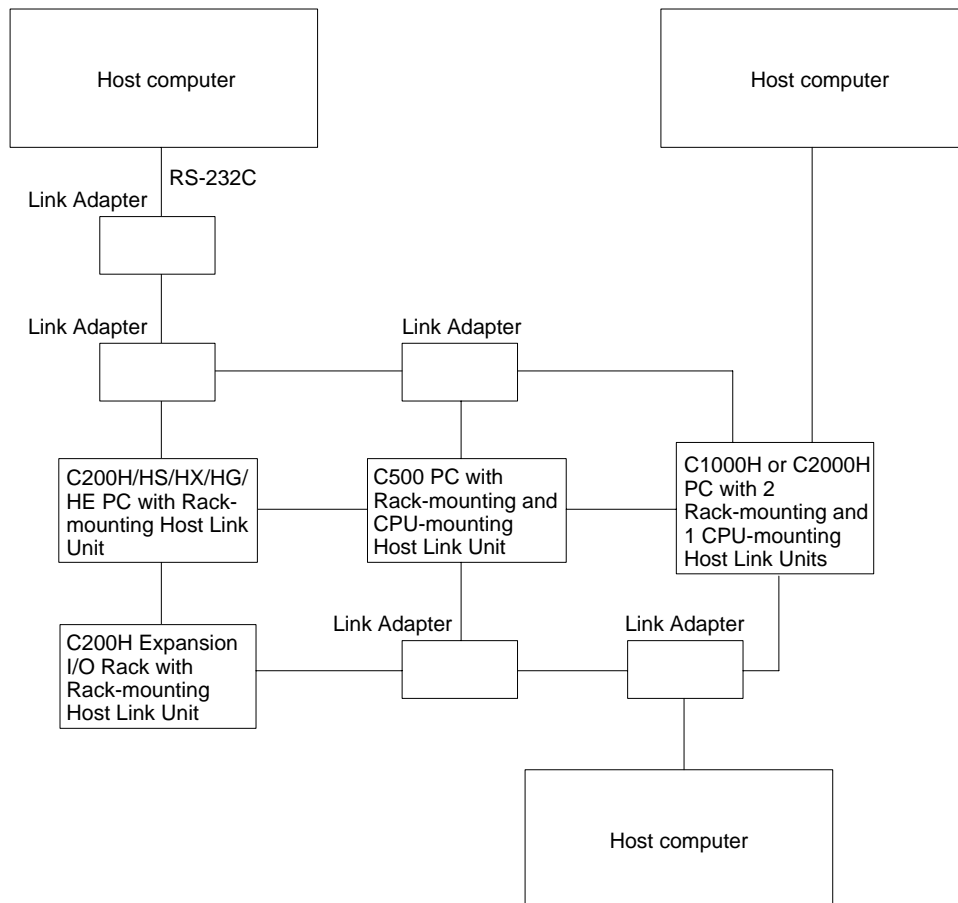

### 1-3 Mounting Host Link Units

The I/O slots onto which the Host Link Units can be mounted are as follows:

PC		I/O slot
C200H/C200HS/C200HX/C200HG/C200HE		Any* slot of the CPU or Expansion I/O Racks
C500, C1000H	with 3G2A5-BC081, 3G2A5-BC051, or C500-BC031 Backplane	Any of the three slots on the right hand side of the CPU Rack
	with C500-BC082, C500-BC052, C500-BC091, or C500-BC061 Backplane	Any of the five slots on the right hand side of the CPU Rack
C2000H simplex system with 3G2C5-BC061 Backplane		Any of the slots on the CPU Rack
C2000H duplex system with 3G2C5-BI082 Backplane		Any of the six slots on the Expansion I/O Rack

\* If mounted to either of the rightmost slots of the CPU Rack, other peripheral devices, such as the Programming Console, cannot be mounted.

**Note** Host Link Unit switches must be set before mounting.

## 1-4 Host Computer Settings

To establish correct data communications with the Host Link Unit, the communications conditions listed below must match on both the host computer and the Host Link Unit. For the actual setting of these conditions, refer to the host computer manual.

### Transmission Speed

The transmission speed of the Host Link Unit must match that of the host computer. See *Section 2 Host Link Unit Characteristics* for the setting procedure.

### Single-character Data Format

Set the host computer to the following 11-bit data format (7-bit ASCII):

Number of start bits: 1  
 Data Length: 7 bits  
 Even (vertical) parity: 1 bit  
 Number of stop bits: 2

For the C200H-LK101-PV1, C200H-LK202-V1, C500-LK103(-P), and C500-LK203 Host Link Units, the following 11-bit format can also be set (8-bit JIS). Make sure that the host computer and Host Link Unit formats match.

Number of start bits: 1  
 Data length: 8 bits  
 Parity (odd or even): 1 bit  
 Number of stop bits: 1

## 1-5 Types of Interfaces

The system must be properly interfaced to enable error-free communications. Use the following information to correctly interface your system.

### 1-5-1 Optical Interface

In an optical fiber system, the maximum transmission distance varies depending on the type of optical fiber cable, which in turn depends on the Host Link Unit model. Refer to the table under in *Appendix C* for optical fiber cable lengths. Optical fiber cable connectors must be assembled by the user.

The products listed in the following table can be used to interface the C500-LK203, 3G2A5-LK201-EV1, C200H-LK201-V1, or the 3G2A6-LK201-EV1 Host Link Unit to a host computer.

Product	Model Number	Quantity Required	Miscellaneous
Optical Interface	Z3RN-A-5	2	RS-232C - optical converter interface
Optical Fiber Cable	Z3F2-4D□M*	1	---
AC Adapter	Z3GP-01	1 or 2	For supplying power to optical interface

\* When ordering, replace the "□" with the desired cable length: 1, 5, 10, 20, 30, 50, 100, 200, 400, or 500 m, e.g., Z3F2-4D30M to order a 30 m cable.

- Note**
1. The optical interface must be provided with a 5 V power supply.
  2. To supply 5 V to a Z3RN-A-5 Optical Interface connected on the host computer side of a Host Link Unit (only with C500-LK203 or C200H-LK201-V1 models), set the 5 V supply switch on the back of the Host Link Unit to ON (up). The normal setting is OFF.
  3. When using a 3G2A5-LK201-EV1 or the 3G2A6-LK201-EV1 Host Link Unit, use the AC adapters to supply 5 V to the Optical Interface on both the Host Link Unit side and the host computer side.

## 1-5-2 RS-232C Interface

(For all but C500-LK203 and insulated types.) When using an optical fiber cable or RS-422 cable, several Host Link Units can be connected to one host computer. When RS-232C cables are used, however, the connection must be made on a one-to-one basis, or a Link Adapter must be used to convert to RS-422 cable or optical fiber cable as shown in *Examples 1 and 2* in *1-2-2 System Examples* (see also *Link Adapters Installation Guide*). The table below gives the proper connections for a RS-232C interface.

Signal*	Symbol	Pin No.
Frame ground	FG	1
Signal ground	SG	7
Send data	SD	2
Receive data	RD	3
Request to send	RS	4
Clear to send	CS	5
Equipment Ready	ER	20
Send signal element timing 1***	ST1	24
Send signal element timing 2***	ST2	15
Receive timing***	RT	17
5-V power supply**	5V	14

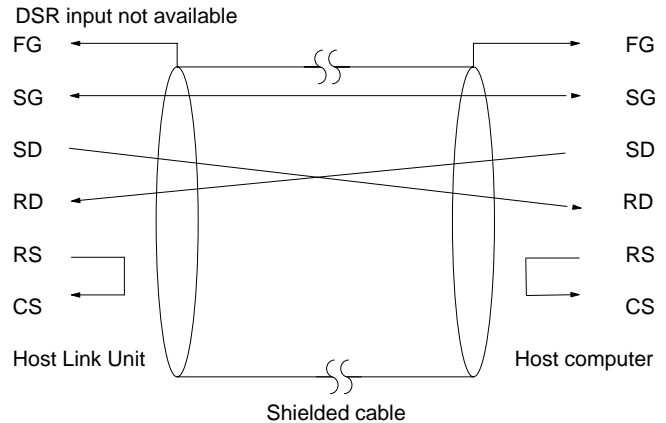

\* Viewed from the Host Link Unit.

\*\* For Optical Interfaces used with the C500-LK203 Host Link Unit.

\*\*\*For synchronous timing (not available with C200H-LK201-V1Host Link Unit).

The maximum cable length is 15 m. Ground the FG terminals of both the PC and the host computer at a point that has a resistance of less than 100  $\Omega$ .

Interfacing to IBM AT via AL004 Link Adapter

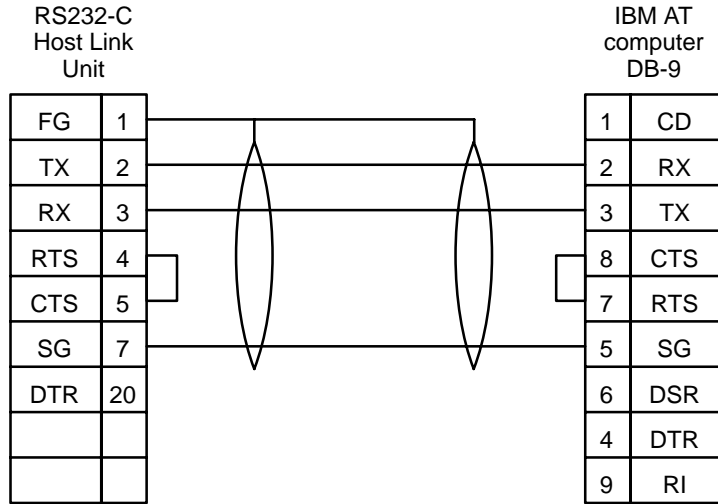

Two-wire system, no handshaking.

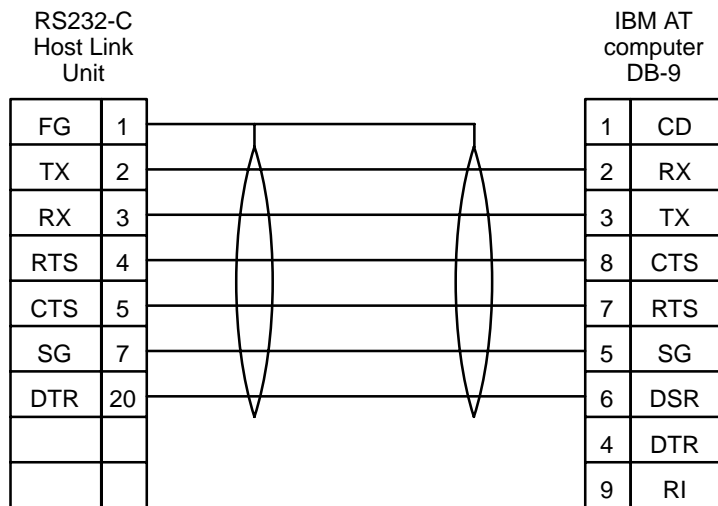

Full handshake configuration.

Interfacing to IBM XT via AL004 Link Adapter

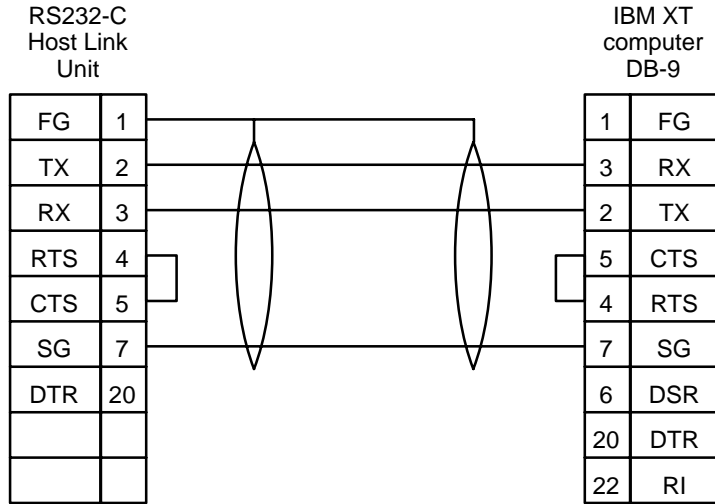

Two-wire system, no handshaking.

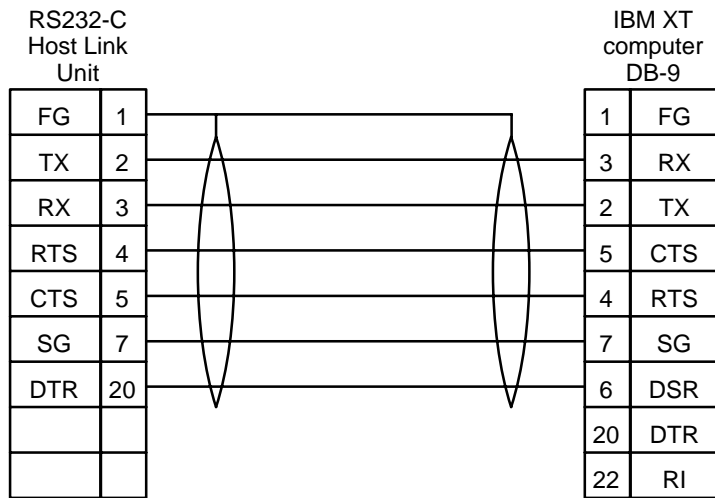

Full handshake configuration.

### 1-5-3 RS-422 Interface

(For all but C500-LK203 and insulated types) The following table details the pin connections for a RS-422 interface.

Signal*	Symbol	Pin No.
Send data A	SDA	9
Send data B	SDB	5
Receive data A	RDA	6
Receive data B	RDB	1
Signal ground	SG	3
Frame ground	FG	7

\* Viewed from the Host Link Unit.

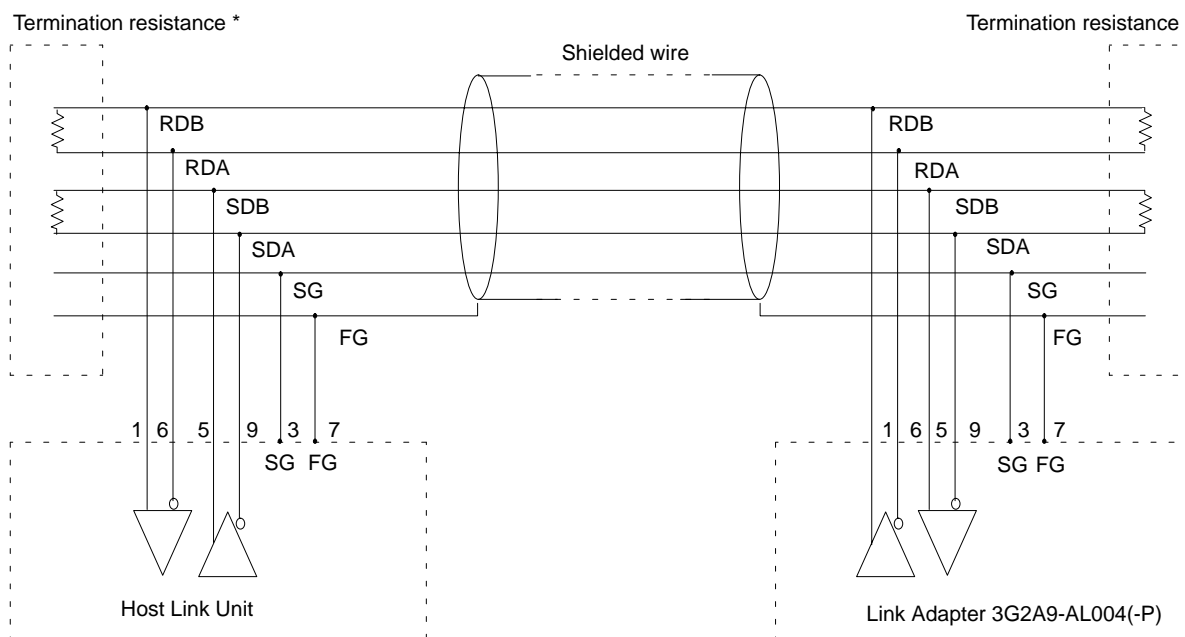

\* The total termination resistance must be  $100\ \Omega$  min.  
The built-in resistance is  $220\ \Omega$ .

The maximum cable length is 500 m. Ground the FG terminals on both the PC and the host computer to a point where the resistance is less than  $100\ \Omega$ . For more information, refer to the PC or host computer manuals.

Interfacing to IBM AT via AL004 Link Adapter

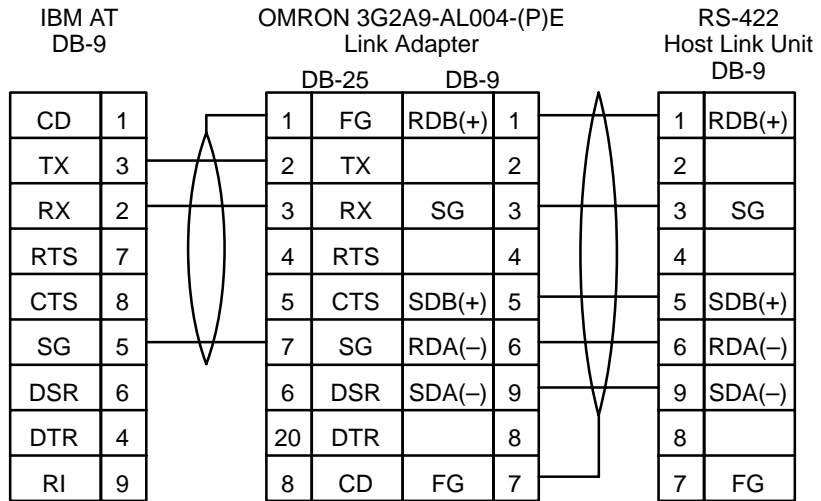

Two-wire system, no hand-shaking.

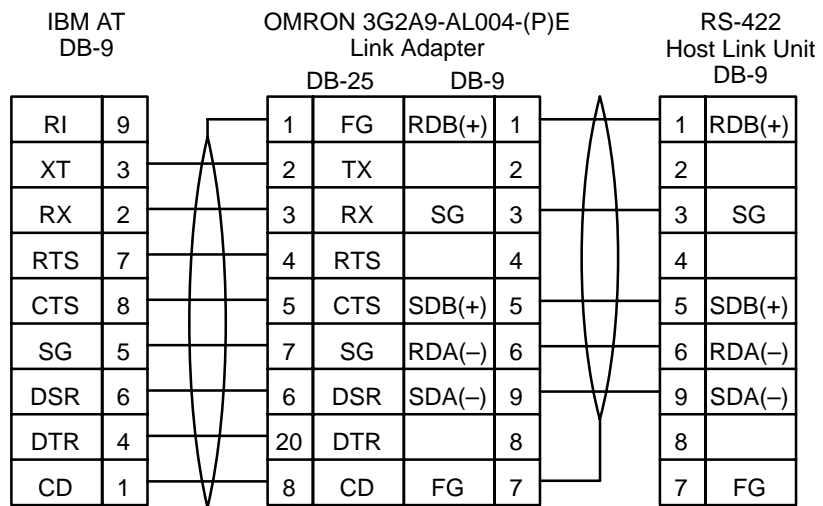

Full handshake configuration.

Interfacing to IBM XT via AL004 Link Adapter

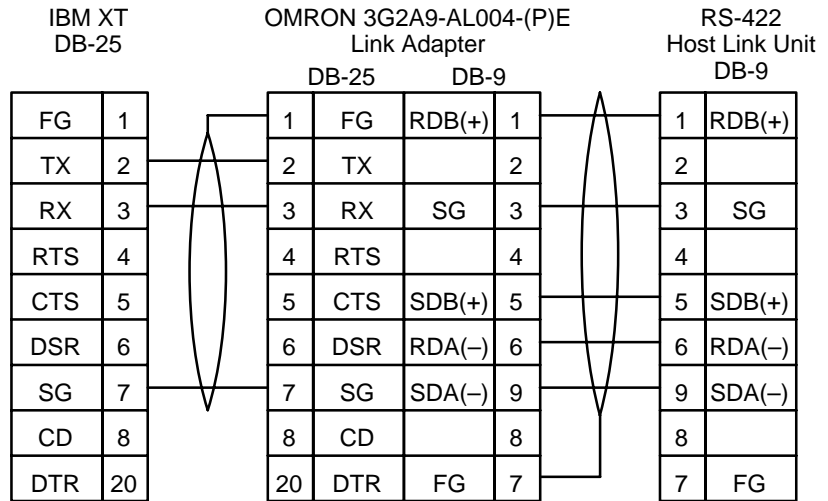

Two-wire system, no hand-shaking.

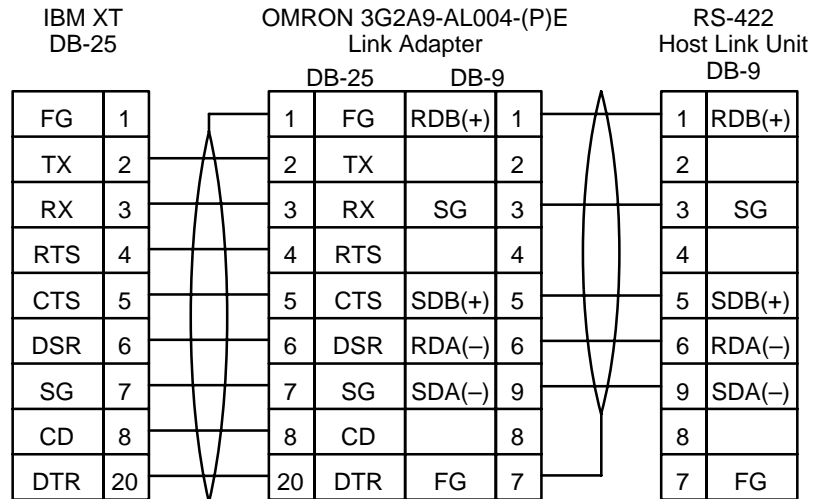

Full handshake configuration.

**RS-422 Interface (For Insulated C500-LK203)**

The table below lists the connections for interfacing a RS-422 cable to an insulated C500-LK203 Host Link Unit.

Signal*	Symbol	Pin No.
Send data A	SDA	9
Send data B	SDB	5
Receive data A	RDA	6
Receive data B	RDB	1
Frame ground	FG	7
Frame ground**	FG	Hood fitting

\* Viewed from the Host Link Unit.

\*\* In order to prevent current flow in the shield wire, make a connection to only one end of it. Either pin 7 or the hood fitting can be used to connect the shield wire to the frame ground.

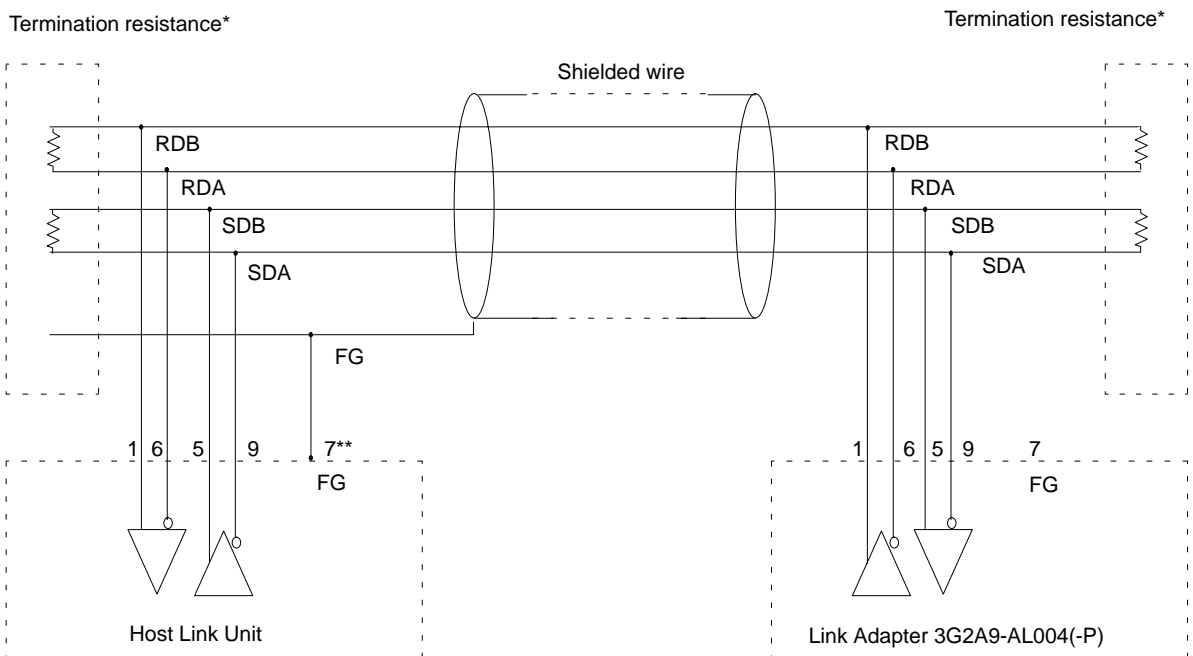

\* The total termination resistance must be 100  $\Omega$  min.  
The built-in resistance is 220  $\Omega$ .

\*\* In order to prevent current flow in the shield wire, make a connection to only one end of it. Either pin 7 or the hood fitting can be used to connect the shield wire to the frame ground.

The maximum cable length is 500 m. Ground the FG terminals of both the PC and the host computer to a point with a resistance of less than 100  $\Omega$ . For details, refer to the PC or host computer manuals.

**C500-LK203 Noise Tolerance** The RS-422 interface on the C500-LK203 Host Link Unit is insulated to improve its tolerance to electrical noise. Although the increased tolerance provides better performance under normal operating conditions, the operation can be affected in very noisy environments. For this reason the optical C500-LK103(-P) is recommended in situations where noise might be a problem.

### FG Connections for Insulated C500-LK203 Host Link Units

In systems which use only the insulated C500-LK203 Host Link Units, connect the frame ground to the shield wire at the connections to the Host Link Units and at either end of the connections between Link Adapters. In systems using the insulated C500-LK203 with other types of Host Link Units, connect the frame ground to the shield wire at connections to the C500-LK203 Host Link Units and at both ends of all connections between Link Adapters and between the other Host Link Units and Link Adapters.

### Multiple-link Connections

When connecting a multiple-link system with RS-422 cable, use shielded twisted pair cables for the Host Link Unit. The total cable length of the entire system must not exceed 500 m. The length of each branch line should be kept to less than 10 m.

The optical Host Link Units can be used to achieve greater distances in the overall system (see *Example 2* in *1-2 System Configuration*). If they are connected in series, however, signals are not transmitted to any Unit that is not supplied with power, or any other Units beyond it. To avoid any problems with this, signals can also be distributed through Link Adapter 3G2A9-AL002-PE. To connect the Host Link Units to the host computer, Link Adapter 3G2A9-AL004-(P)E is necessary to be able to interface the optical fiber cables and the RS-232C and RS-422 cables.

## 1-6 Wiring RS-232C and RS-422 Cable Connectors

The following procedures should be followed when wiring RS-232C and RS-422 connectors.

### 1-6-1 Preparation for Connecting Shielded Cable to FG

The procedures listed below correspond to the following diagrams.

- 1, 2, 3...
1. Cut the cable to the required length.
  2. Use a razor blade to cut away the sheath (being careful not to damage the braiding underneath): 25 mm for RS-422 cable; 40 mm for RS-232C cable.
  3. Use scissors to cut away all but 10 mm of the exposed braiding.
  4. Use wire strippers to remove the insulation from the last 5 mm of each wire.
  5. Move the boot to cut the edge of the sheath and fold the braiding back over the end of it.
  6. Wrap aluminum foil tape over the top of the braiding on top of the boot for one and a half turns.

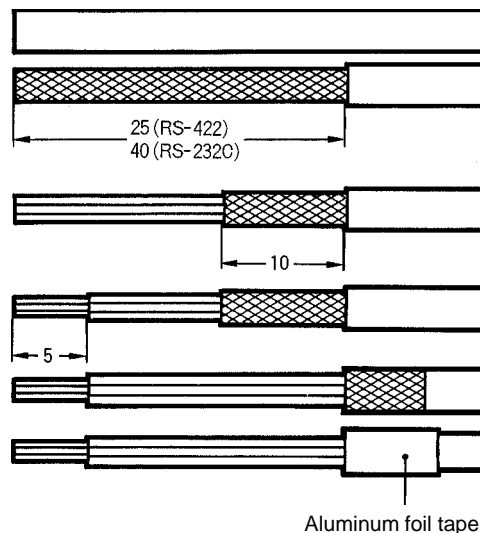

## 1-6-2 Preparation for Connecting Unshielded Cable to FG

The procedures outlined in the list below correspond to the following diagrams.

- 1, 2, 3...
1. Cut the cable to the required length.
  2. Use a razor blade to cut away the sheath: 25 mm for RS-422 cable; 40 mm for RS-232C cable.
  3. Use scissors to cut away the exposed braiding.
  4. Use wire strippers to remove the insulation from the last 5 mm of all wires.
  5. Wrap insulating tape over the top and end of the the cut sheath.

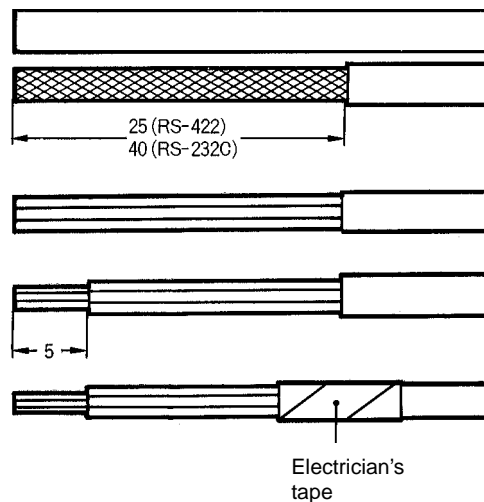

### Soldering

Observe the following when soldering the prepared wires onto the connectors.

- 1, 2, 3...
1. Place heat-shrinking tubes over all wires, far enough away from the end so as not to interfere with the soldering.
  2. Pre-solder all wires and connector terminals.
  3. Solder wires, inserting 4 mm of the exposed 5 mm of wire into the connector terminal.

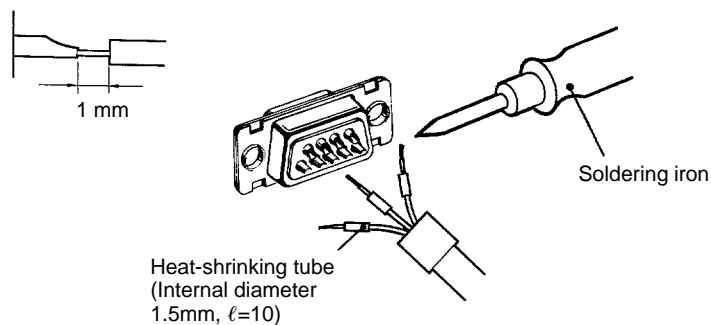

4. Move the heat-shrinking tubes onto the soldered area and shrink them into place.

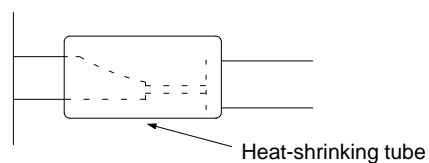

Hood Assembly

Assemble the hood as shown in the following diagram.

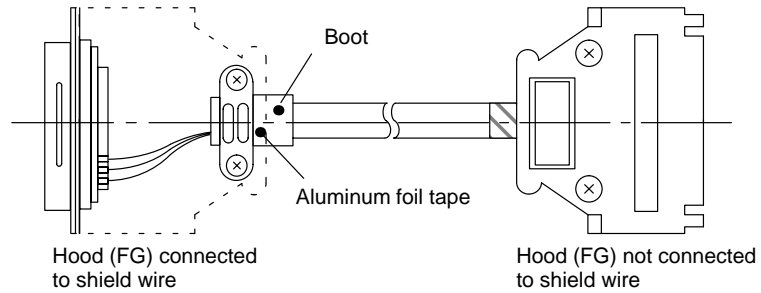

1-6-3 FG Connection to the Cable's Shield Wire (RS-422 Interface)

Connection of C500-LK203 Host Link Units

When connecting a Host Link Unit and a Link Adapter, connect the cable's shield wire to the Host Link Unit's FG. Do not connect the shield wire to the Link Adapter's FG.  
 When connecting two Link Adapters, connect the cable's shield wire to either Link Adapter's FG.

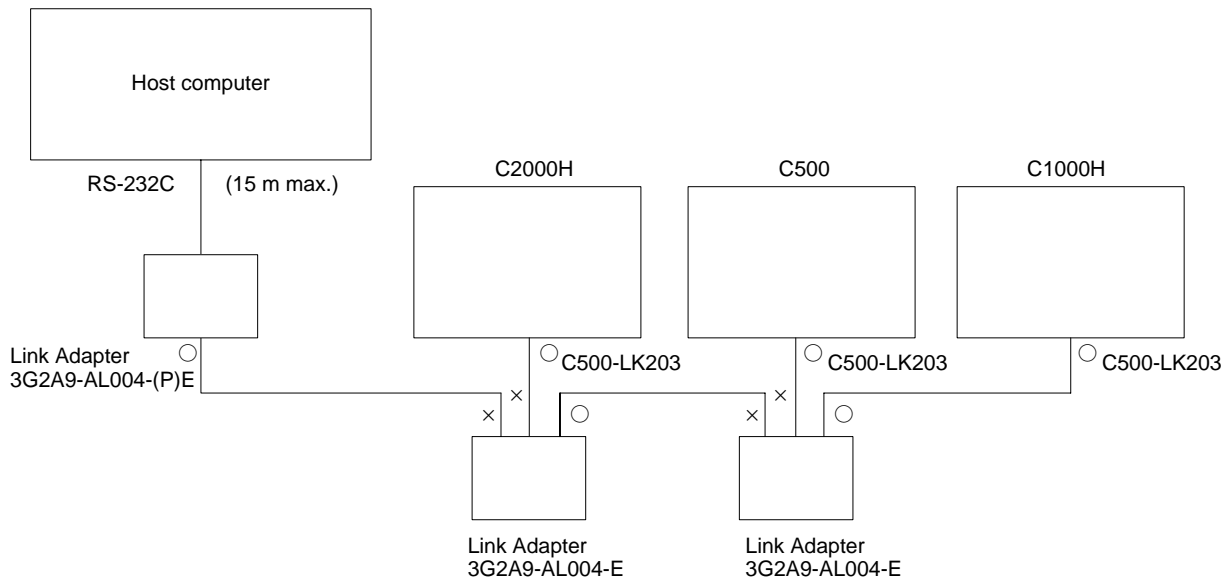

**Note** Just one end of the shield wire is connected to FG to prevent current from flowing in the shield wire.  
 ○: Connect the shield wire to FG.  
 x: Do not connect the shield wire to FG.

**Connection of C500-LK203 with other Host Link Units**

When connecting a C500-LK203 and a Link Adapter, connect the cable's shield wire to the C500-LK203 Host Link Unit's FG. Do not connect the shield wire to the Link Adapter's FG.

When connecting a Host Link Unit (other than a C500-LK203) and a Link Adapter, connect the both ends of the cable's shield wire to the FGs. Also connect both ends to the FG's when connecting two Link Adapters.

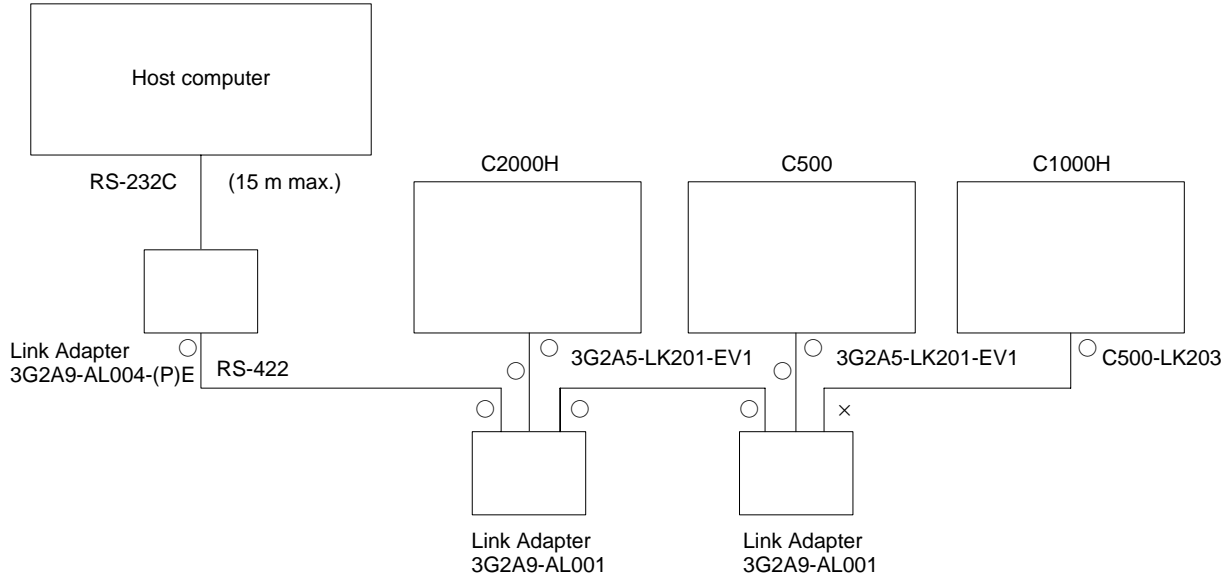

**Note** Just one end of the shield wire is connected to FG to prevent current from flowing in the shield wire.

- : Connect the shield wire to FG.
- x: Do not connect the shield wire to FG.

**1-6-4 Wiring**

**Connection of Optical Host Link Units**

Optical Host Link Units (C200H-LK101-PV1, 3G2A5-LK101-(P)EV1, C500-LK103(-P), and 3G2A6-LK101-(P)EV1) are connected sequentially with Optical Fiber Cable. Consequently, Units cannot transmit if they follow a Unit that is turned off. Branches can be made in the Optical Fiber Cable with a 3G2A9-AL002-(P)E Link Adapter.

When connecting a host computer, a 3G2A9-AL004-(P)E Link Adapter is required to convert Optical Fiber Cable to RS-232C or RS-422.

Wiring Example

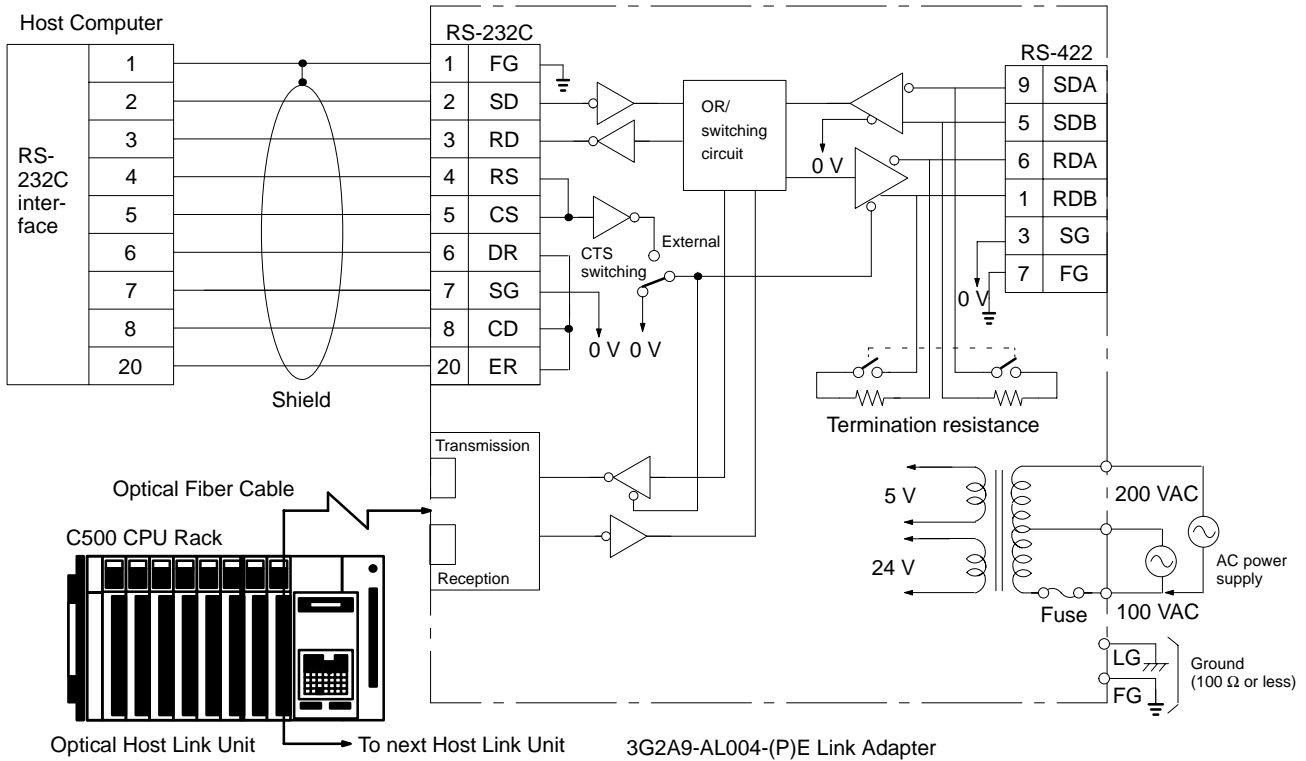

Be sure to use a wire of at least 1.25 mm<sup>2</sup> in thickness.

Use M4 screws for tightening crimp terminals.

Use ring crimp terminals for wiring. Do not connect bare stranded wires directly to terminal blocks.



**Caution**

Tighten the screws on the terminal block of the AC Power Supply Unit to a torque of 1.2 N·m. The loose screws may result in burning or malfunction.

**Switch Settings**

**CTS (CS) Switching (Link Adapter Settings)**

Set to “0 V” when the CTS (Clear-To-Send) signal will usually be ON. Set to “External” when the signal is received externally. This switch is normally set to “0 V.”

**Note**

Always cap unused Optical Connectors. If the connectors are not capped, ambient light interference can enter the Optical Connectors and cause transmission errors.

**1:1 Connection of Host Computer and Host Link Unit**

The following diagram shows a 1:1 connection of a host computer and a Host Link Unit (C200H-LK202-V1, 3G2A5-LK201-EV1, C500-LK203, or 3G2A6-LK202-EV1).

**Wiring Example**

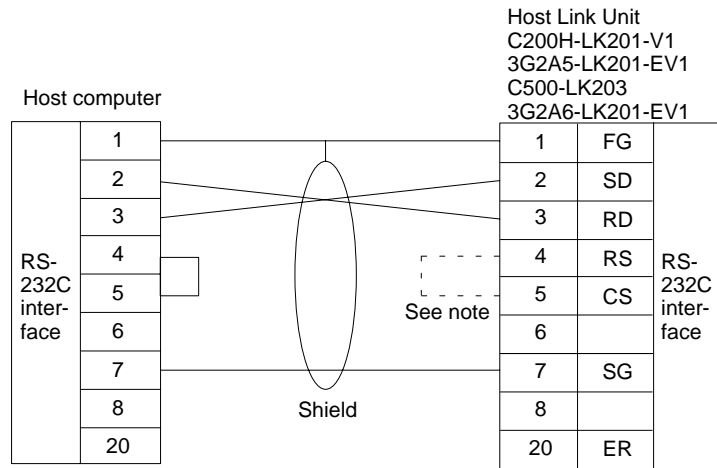

**Note** It is not necessary to connect the RS and CS signals if the CTS switch on the back of the Host Link Unit is set to 0 V. Set the I/O port switch on the back of 3G2A5-LK201-EV1/C500-LK203 Host Link Units to "RS-232C."

**1:N Connection of Host Computer and Host Link Unit**

Set to 0 V when the CTS (Clear-To-Send) signal will usually be ON. Set to External when the signal is received externally. This switch is normally set to 0 V.

**Wiring Example**

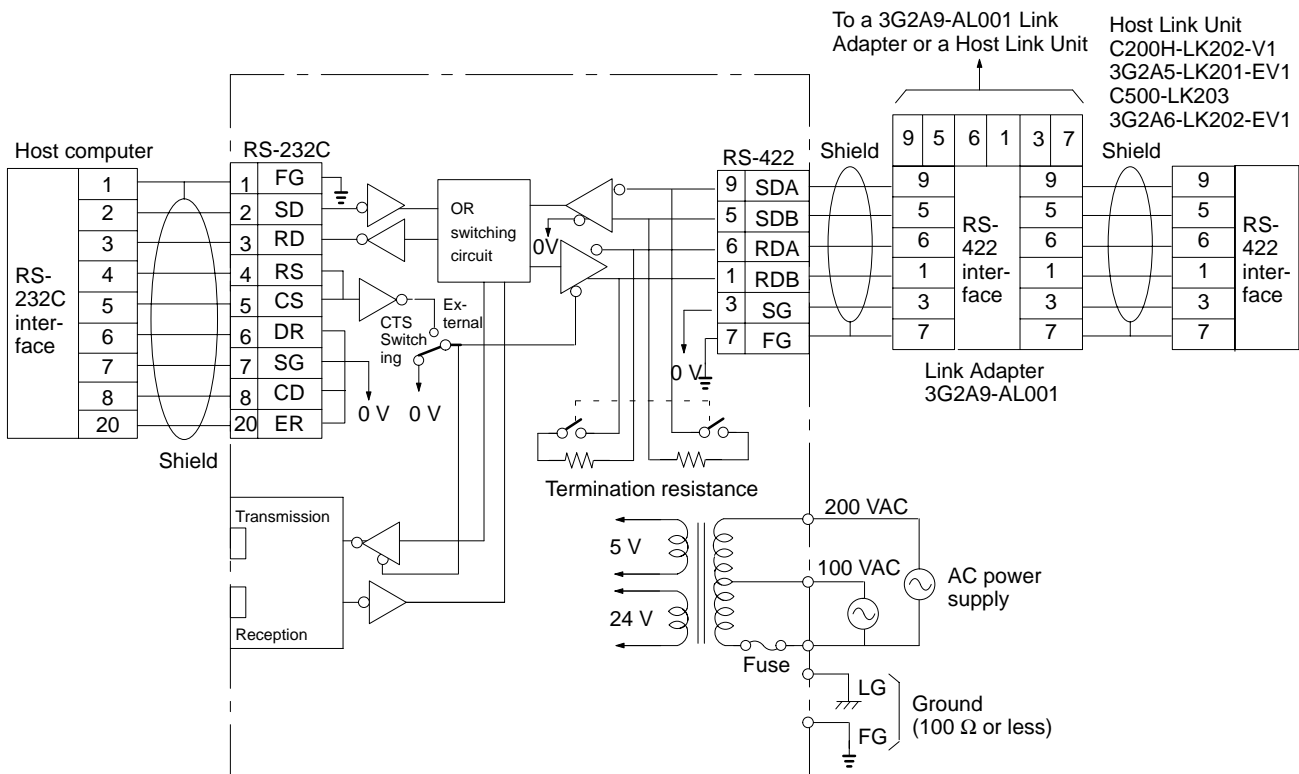

**Note** Set the I/O port switch on the back of 3G2A5-LK201-EV1/C500-LK203 Host Link Units to “RS-422.”

Be sure to use a wire of at least 1.25 mm<sup>2</sup> in thickness.

Use M4 screws for tightening crimp terminals.

Use ring crimp terminals for wiring. Do not connect bare stranded wires directly to terminal blocks.

 **Caution** Tighten the screws on the terminal block of the AC Power Supply Unit to a torque of 1.2 N·m. The loose screws may result in burning or malfunction.

## SECTION 2

# Host Link Unit Characteristics

This section provides the switch location and setting details for each group of Host Link Units. The Units are grouped according to the operating characteristics. C200H Units are dealt with first, followed by C500 and 3G2A5 models, and 3G2A6 models are included at the end of the section.

For each grouping, labelled pictures of the different models show the positions and names of the switches and connections. The functions of the switches are then explained. The effects of the Host Link Units and other peripheral devices on the operating mode of the PC System are discussed, followed by a section on the I/O Response Times.

The systems and PCs that apply to each Host Link Unit are given in the table at the beginning of *Section 1*.

2-1	C200H Host Link Units .....
2-1-1	Nomenclature and External Appearance .....
2-1-2	Switch Settings .....
2-1-3	Indicators .....
2-1-4	PC Operating Modes .....
2-1-5	Restart Bits and Error Flags .....
2-1-6	I/O Response Time .....
2-2	C500 (3G2A5) Host Link Units .....
2-2-1	Nomenclature and External Appearance .....
2-2-2	Switch Settings .....
2-2-3	Indicators .....
2-2-4	PC Operating Modes .....
2-2-5	Restart Bits and Error Flags .....
2-2-6	I/O Response Time .....
2-3	C120 (3G2A6) Host Link Units .....
2-3-1	Nomenclature and External Appearance .....
2-3-2	Switch Settings .....
2-3-3	Indicators .....
2-3-4	PC Operating Modes .....
2-3-5	Restart Bits and Error Flags .....
2-3-6	I/O Response Time .....
2-4	Installing and Removing Host Link Units .....

## 2-1 C200H Host Link Units

### 2-1-1 Nomenclature and External Appearance

The following figures give details of switch types, selectors, and connectors for your Host Link Unit. It will be necessary to refer to these diagrams from time to time as you read further in the manual, particularly when reading the section on 2-1-2 Switch Settings.

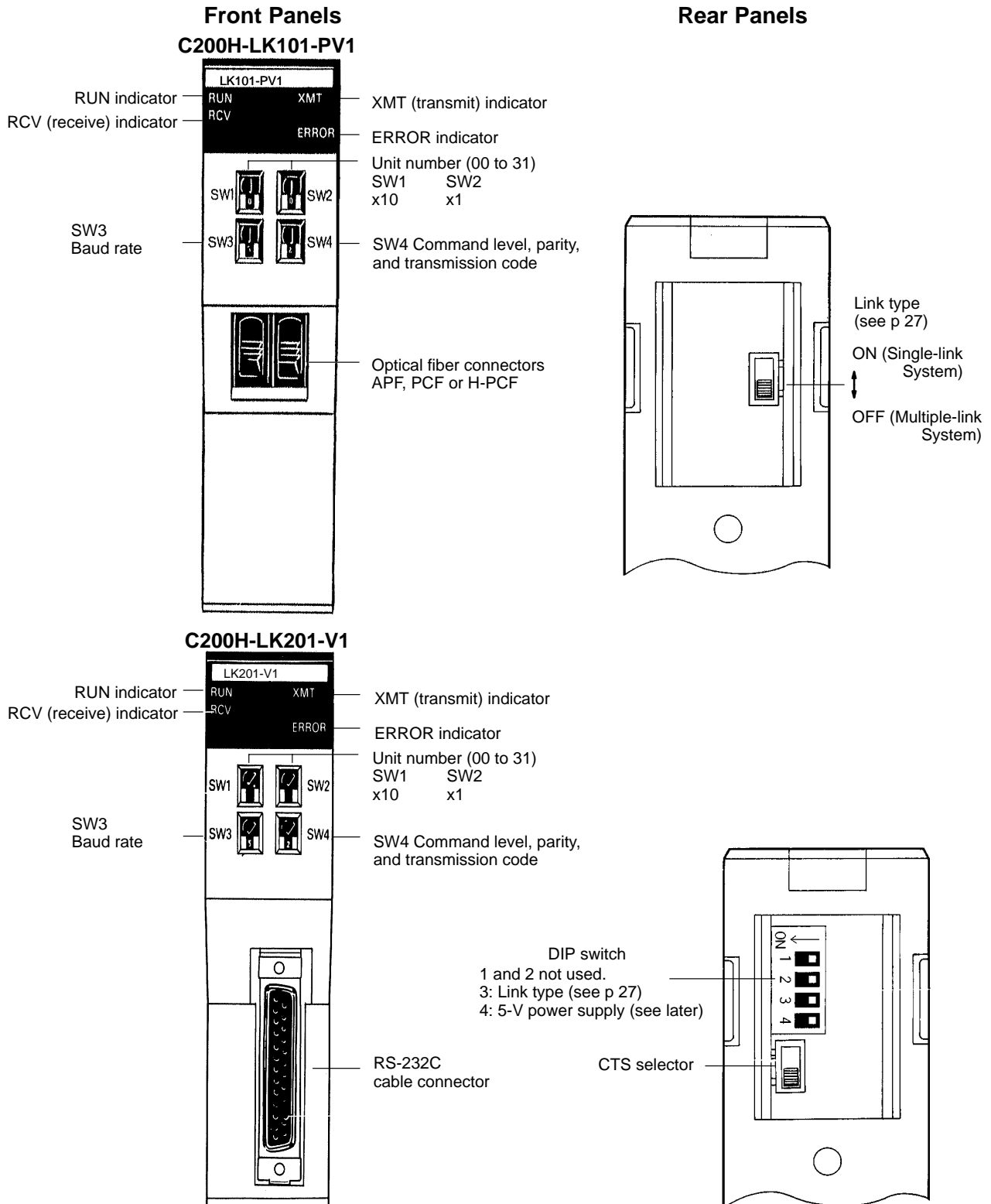

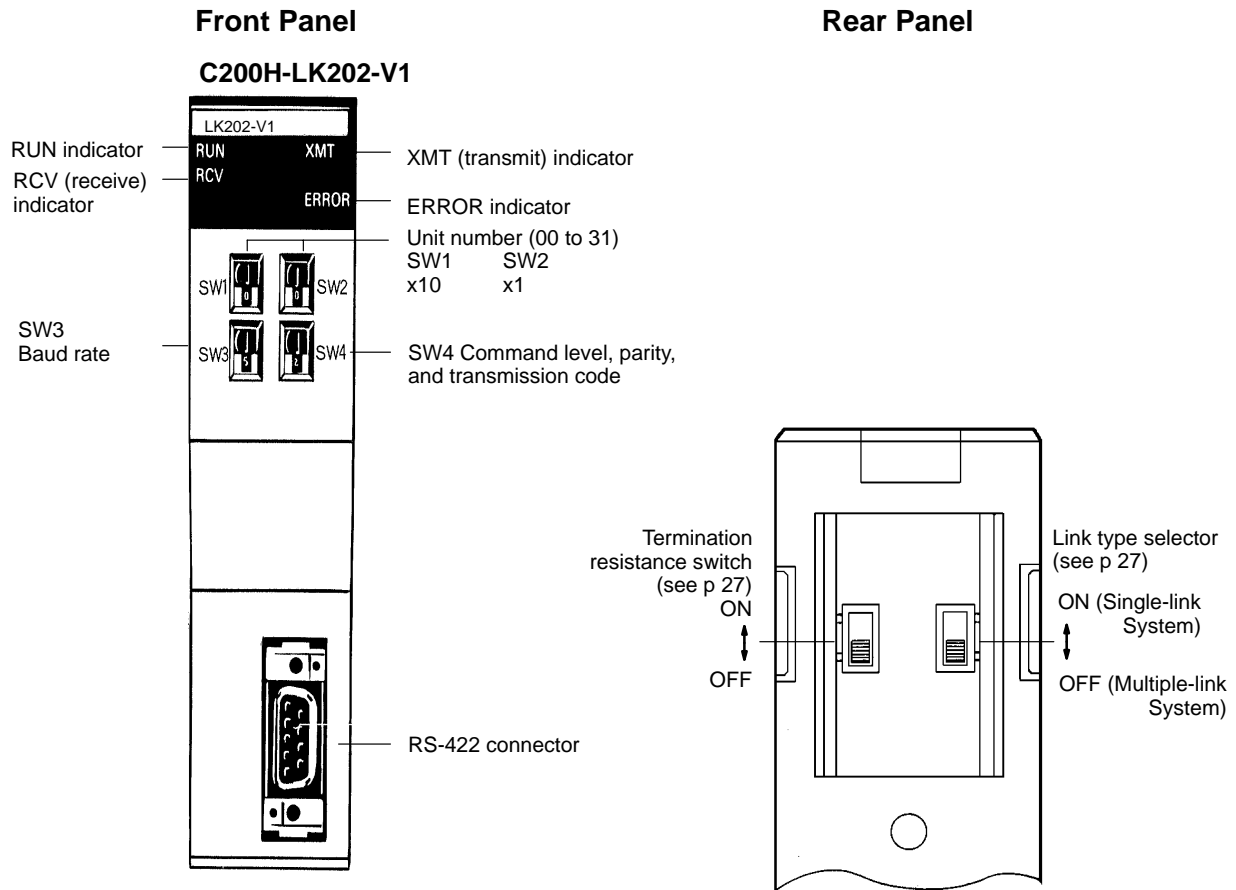

## 2-1-2 Switch Settings

The following information provides details on correct settings for the range of Host Link Units covered by this manual. Pay particular attention to the RUN/STOP and MONITOR/NORMAL switches on the C1000H-style cards.

### SW1 and SW2

These switches are used to set the Unit number. The same unit number must not be specified for more than one Unit.

### SW3: Baud Rate

The baud rate of the Host Link Unit, as determined by the following switch settings, must match that of the host computer.

SW3	Baud rate
0	300 bps
1	600 bps
2	1,200 bps
3	2,400 bps
4	4,800 bps
5	9,600 bps
6	19,200 bps
7	
8	Do not set
9	

**SW4: Command Level, Parity and Transmission Code**

SW4	Command Level*	Parity	Transmission Code
0	1	Even	ASCII 7 bit, 2 stop bits
1	1,2		
2	1,2,3**		
3	Do not set		
4	1	Odd	
5	1,2		
6	1,2,3		
7	Do not set		
8	1	Even	JIS 8 bit, 1 stop bit
9	1,2		
A	1,2,3		
B	Do not set		
C	1	Odd	
D	1,2		
E	1,2,3		
F	Do not set		

\* See descriptions of Command Levels at the end of this sub-section.

\*\* Use this setting when using LSS (Ladder Support Software)

**Mode Selection**

C200H Units are automatically set to HOST mode. See 2-1-4 *PC Operating Mode* for further details.

**Termination Resistance**

When using a RS-422 cable (C200H-LK202-V1 Host Link Units) throughout a system, the Host Link Unit at each end of the cable system (as detailed in the following diagram) must have the termination resistances connected by turning ON the switch on the back of the panel. When this switch is set to ON, a built-in termination resistance of 220 Ω is connected. When set to OFF, the termination resistance is disconnected.

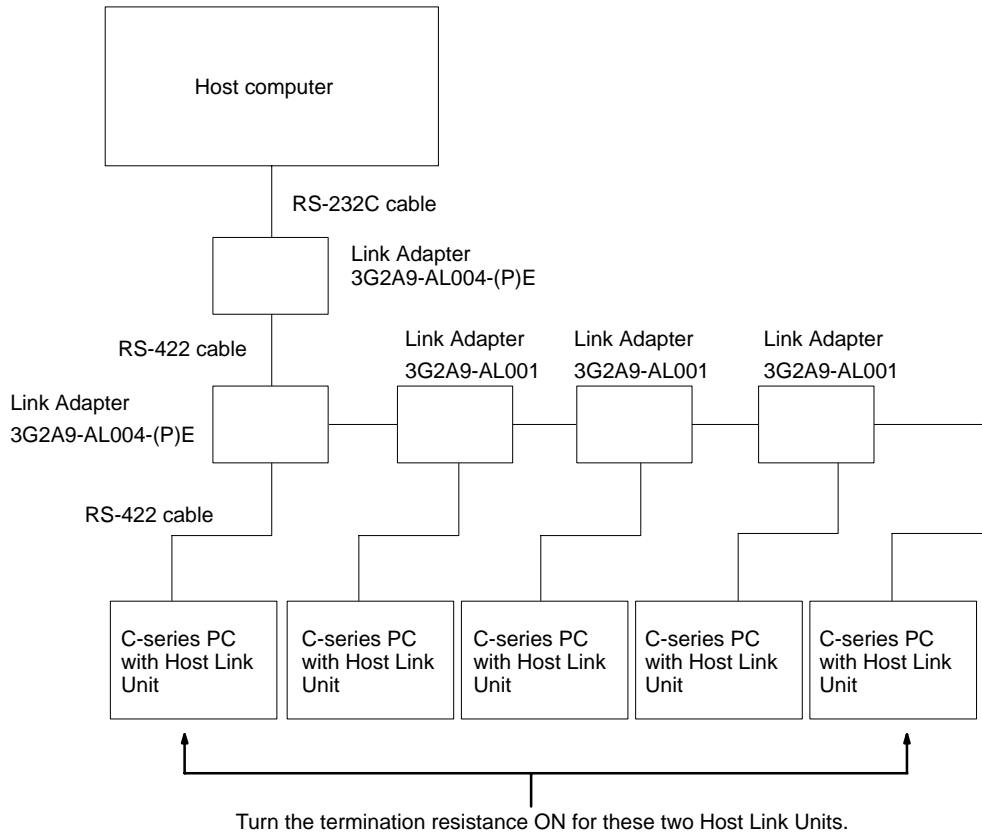

**CTS Selector**

For RS-232C models (C200H-LK201-V1), the selector is set to 0 V, the clear-to-send (CTS) signal is continuously ON. When the selector is set to external, the Unit will respond to externally generated CTS signals. This is normally set to CTS always ON, i.e., the switch is set to ON.

**5-V Power Supply Switch**

When using a Z3RN-A-5 Optical Interface with an RS-232C Host Link Unit, the 5 V power supply switch should be set to ON; otherwise it should be set to OFF. On the C200H-LK201-V1, pin 4 on the back-panel DIP switch functions as the 5 V power supply switch.

**Link Type Selector**

Pin 3 on the back-panel DIP switch of the C200H-LK201-V1 (RS-232C connection), and the Link Type Selector on the rear of the C200H-LK101-PV1 (optical fiber connection) provide the same functions as described below.

OFF (Single-link):

If set to OFF, the Host Link Unit is connected to the host computer on a one-to-one basis (see *Example 3* and *Example 5* under *1-2 System Configuration*). The Unit number and Frame Checksum (FCS) settings are not required. The normal setting is ON (see below).

ON (Multiple-link):

If set to ON, up to 32 Host Link Units can be connected to one host computer. The unit number and FCS must be specified, even if only one Host Link Unit is connected to the host computer. When using Ladder Support Software, LSS, the switch must be set to ON.

## Command Levels

- 1, 2, 3...
1. Enables data areas to be read and, when the CPU has been correctly set via the SC (Status Write) command, data can also be written.
  2. Enables program transfers and reading or writing of I/O tables.
  3. I/O READs can be performed and I/O tables can be registered. The Command Level should be set to "1, 2, 3" for running LSS software, program transfers, etc. Other levels may be used for Systems Control Software, monitoring, Data Acquisition Software, etc.

**Note** Commands valid for each level are listed in *3-1 Command Levels*.

## 2-1-3 Indicators

Indicator	Function
RUN	ON when the Unit is operating. Depending on the settings of switches 1 to 4, this indicator will blink when an error occurs. (See notes.)
RCV	ON when the Host Link Unit is receiving data.
XMT	ON when the Host Link Unit is transmitting data.
ERROR	Goes ON when a transfer error is detected (See note 1.); goes OFF when a new command is received normally. Goes ON when an error is detected in communications with the CPU. The RUN indicator will blink in this case. (See note 2.)

- Note**
1. Transfer errors include parity, framing, overrun, and FCS errors.
  2. Operation of the Unit is stopped when the RUN indicator is OFF or blinking. Restart the Unit after setting switches 1 to 4 correctly.
  3. Refer to *5-4 Troubleshooting* for details on correcting the following problems.
    - The RUN indicator does not light.
    - The Host Link Unit's RCV indicator does not light when data is transmitted from the host computer.
    - The RCV indicator lights, but the XMT indicator does not.
    - The ERROR indicator lights.
    - The XMT indicator lights, but the host computer does not receive the data.

## 2-1-4 PC Operating Modes

The operating mode of the PC depends on the Memory Unit's Initial Mode setting, the RUN/STOP on the any CPU-mounted Host Link Unit, and the status of any peripheral device connected to the PC. Refer to the following table for details.

### PC Mode on Applying Power with the Host Link Unit Mounted

System configuration and Host Link Unit setting		Memory Unit Initial Mode setting	
		Normal (OFF)	Run (ON)
With no CPU-mounted device		RUN	RUN
With CPU-mounting Host Link Unit	RUN	RUN	
	STOP	PROGRAM	
With CPU-mounting peripheral device		PROGRAM	
With Programming Console		The mode is determined by the mode selector on the Console, i.e., RUN, MONITOR or PROGRAM.	

**Data Flow**

The diagram below shows the flow of data between the system using C200H Host Link Units, and a Programming Console. As can be seen, the Programming Console can be used for monitoring, or for writing to the PC System.

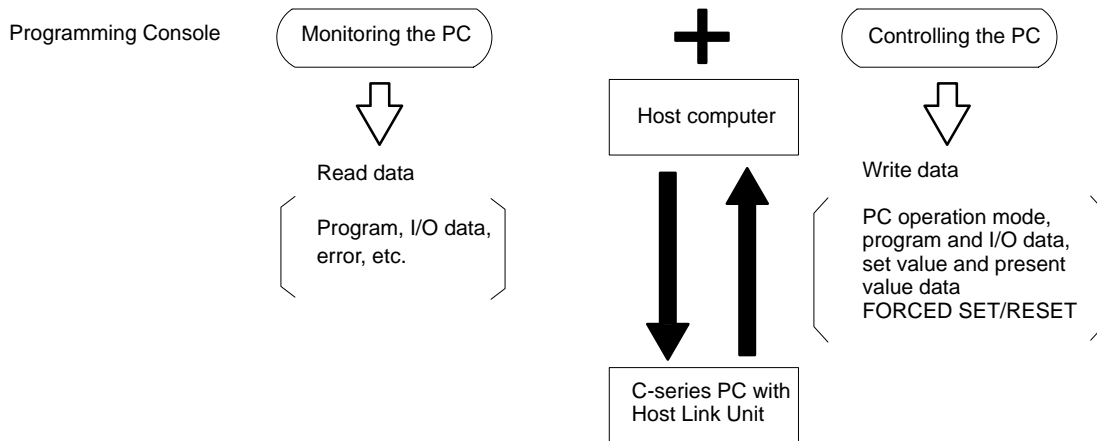

**Controlling PC Start-up**

PROGRAM mode cannot be achieved manually when C200H Rack-mounting Host Link Units are used without a Programming Console or other peripheral device. Programming can be implemented, however, to prevent the PC from automatically starting when the power is applied. This allows greater control and the Unit can be started later with a command from the host computer. The following is an example of a programmed start-up for a C1000H PC.

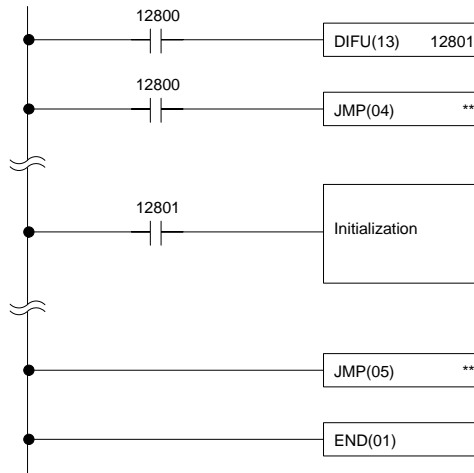

Appropriate initialization codes must be programmed between JMP(04) and JME(05). IR area bit 12800 can then be turned on to start PC operation from the host computer. The PC must be set in MONITOR mode for this to be possible. To initialize the PC when starting operation, use DIFU with the Always ON Flag; the Reset Flag cannot be used. Refer to your PC's operation manual for specific bits. The PC's operating mode can then be changed from the host computer after operation has begun. When programming in this fashion, note the following conditions:

- 1, 2, 3... 1. Before turning on the IR area bit 12800, set the C200H Host Link Units to MONITOR mode using the host computer.
2. JMP command numbers must be between 01 and 99 for C200H/HS, C1000H, and C2000H PCs.

### Sending a RUN Start Command to the PC

The following flowchart shows the computer decision making processes for ensuring that the PC is in RUN mode after start-up.

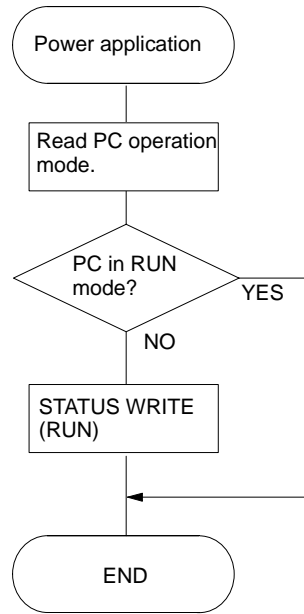

### 2-1-5 Restart Bits and Error Flags

Host Link Units use some of the Special Relay (SR) area and Auxiliary Relay (AR) area bits of the PC to restart the communications control program of the Host Link Unit and to indicate the occurrence of communications errors between the Unit and the computer. The word (Wd) addresses and bit numbers of these bits are as follows:

	Bit 15	Bit 14	Bit 13	Bit 12	Bit 11	Bit 10	Bit 9	Bit 8	Bit 7	Bit 6	Bit 5	Bit 4	Bit 3	Bit 2	Bit 1	Bit 0
SR Wd 252			RM* #0 connection error flag				CM* restart bit	CM* error flag	RM* #1 connection error flag	RM* #1 HC** error flag						
SR Wd 253					RM* #0 HC** error flag											
AR Wd 00			RM* #0 CPU** error flag	RM* #1 CPU** error flag												
AR Wd 24	CM* restart bit	RM* #0 connection error flag	RM* #1 connection error flag													
AR Wd 267			RM* #1 Transmission ready (C200HS/HX/HG/HE only)								RM* #0 Transmission ready (C200HS/HX/HG/HE only)					

\* RM: Rack-mounting Host Link Unit  
 CM: CPU-mounting Host Link Unit  
 \*\* HC: Error between the Host Link Unit and the host computer  
 CPU: Error between the Host Link Unit and the CPU of the PC

### Host Link Unit Restart Bit

When this bit is turned ON, the Host Link Unit is reset to its initial conditions, as if the power had just been applied.

**Caution** Do not turn this bit ON in the user program; doing so could cause the memory to be lost.

### Host Link Unit Error Flag

This flag turns ON if a transmission error occurs between the PC and the Host Link Unit. It turns ON the error indicator on the front of the Unit.

- Note**
1. When the Host Link Unit Restart bit is turned ON, the Host Link Unit Error Flag is turned OFF.
  2. Set the Host Link Unit to LOCAL mode before force setting or force resetting an error flag.
  3. With all but C200H Rack-mounting Host Link Units, communications between the Host Link Unit and the host computer will not be resumed until the Restart bit is turned OFF. The initialization process is repeated as long as the Restart bit is ON.

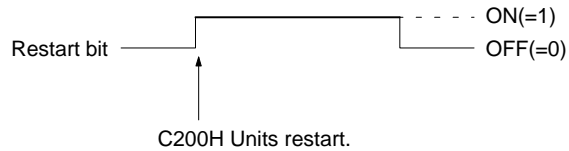

4. If the error condition does not clear, disconnect and then reconnect the power to the PC.

### Error Location

The following example for a Rack-mounting Host Link Unit with an assigned operating level 0, indicates the process flow used in locating errors.

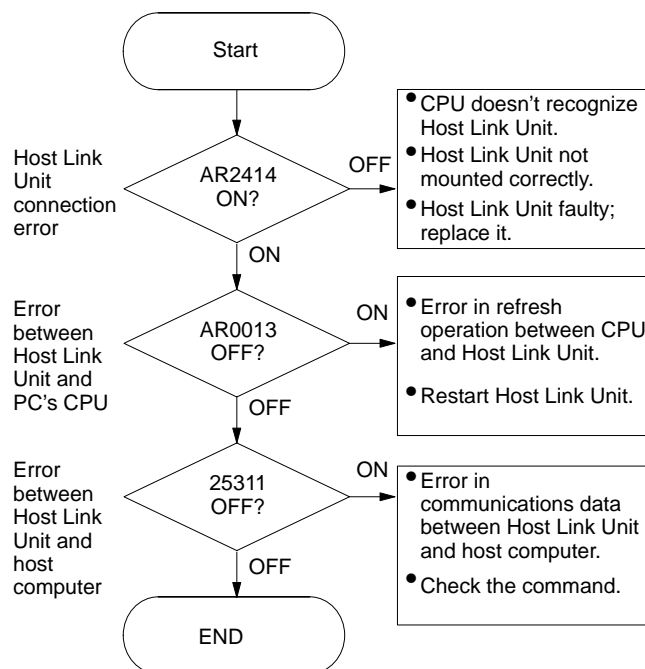

## 2-1-6 I/O Response Time

The processing that determines and the methods for calculating the minimum and maximum times required from an input on one PC with a Host Link Unit to an output on another PC with a Host Link Unit are described below. The transfer between the PCs is handled through a host computer connected to both these PCs.

Processing and calculations are described by PC model in the first subsection and for Systems combining C200H/HS/HX/HG/HE and C1000H PC models in the last subsection. Although more precise equations may be written if required, those used in the following calculations do not consider fractions of a cycle.

The calculations used in this section assume that all host computer commands and PC responses require no more than one host link servicing period to complete transmission. To compute response times for situations involving a longer command and/or response, the number of host link servicing periods (i.e., the number of cycles) required to complete the command or response would have to be incorporated into the equations.

In considering response times, it is important to remember the sequence of processing that occurs during the PC cycle. The main factor that affects the response time is the timing of inputs and outputs and of host computer processing in relation to this sequence.

The following diagram illustrates the setup used in response time calculations

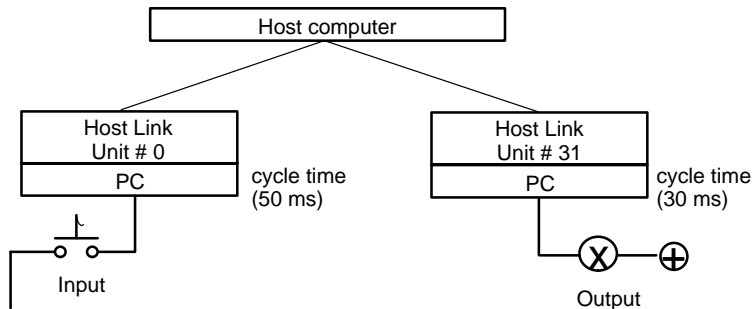

The following equations can be used as required to calculate the minimum and maximum response times with the C200H. The maximum response time is an approximation.

Minimum response time = Input ON delay + Command transmission time + (cycle time of PC for Unit #0 x 3) + Response transmission time + Host computer processing time + Command transmission time + (cycle time of PC for Unit #31 x 3) + Output ON delay

Maximum response time = Input ON delay + Command transmission time + (cycle time of PC for Unit #0 x 10) + Response transmission time + Host computer processing time + Command transmission time + (cycle time of PC for Unit #31 x 10) + Output ON delay

### Combined Systems

When transferring data from one model of PC through a host computer and then out to a different model of PC, all that is necessary is to combine the first half of the minimum/maximum equation for the origin PC with the second half of that for the destination PC. For example, the following equation can be used for the minimum response time when transferring from a C200H/HS/HX/HG/HE to a C1000H.

Minimum response time = Input ON delay + Command transmission time + (cycle time of PC for Unit #0 x 3) + Response transmission time + Host computer processing time + Command transmission time + Output ON delay

## 2-2 C500 (3G2A5) Host Link Units

### 2-2-1 Nomenclature and External Appearance

The following figures give details of switch types, selectors, and connectors for your Host Link Unit. It will be necessary to refer to these diagrams from time to time as you read further in the manual, particularly when reading the section on 2-2-2 *Switch Settings*. These Units are suitable for use with C500, C1000H, and C2000H PCs.

#### Front Panels

##### C500-LK103(-P)

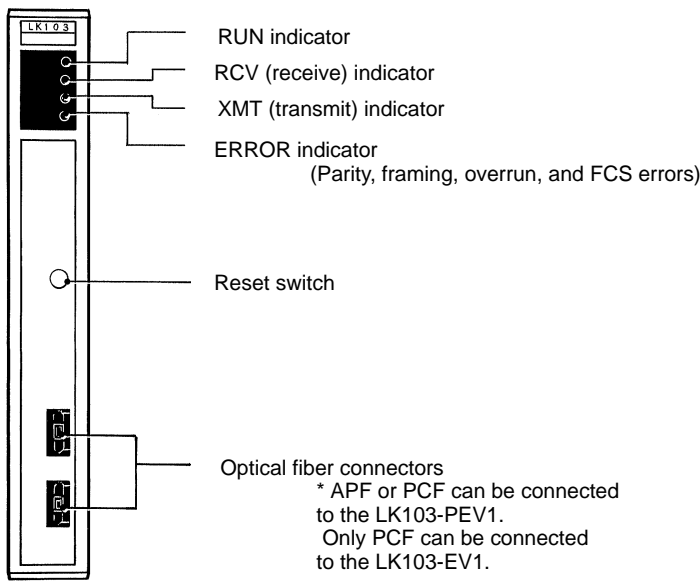

##### 3G2A5-LK101(-P)EV1

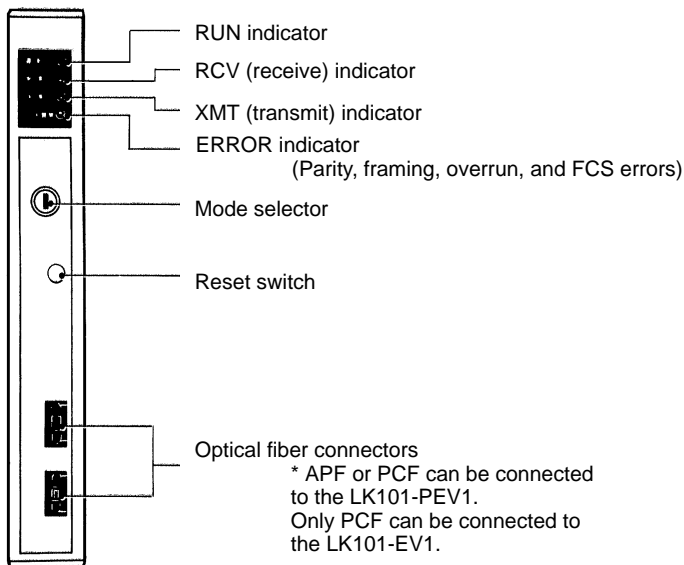

#### Rear Panels

##### 3G2A5-LK101(-P)EV1 C500-LK103(-P)

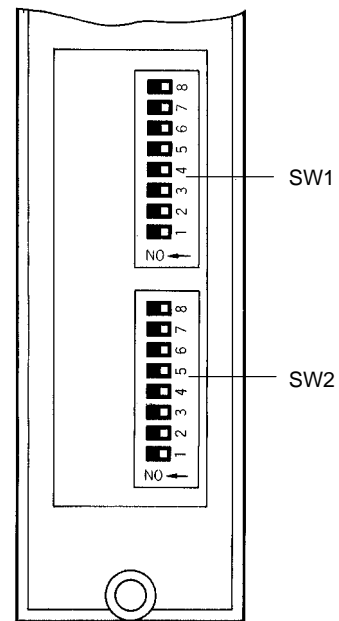

Front Panels

Rear Panels

3G2A5-LK201-EV1

3G2A5-LK201-EV1

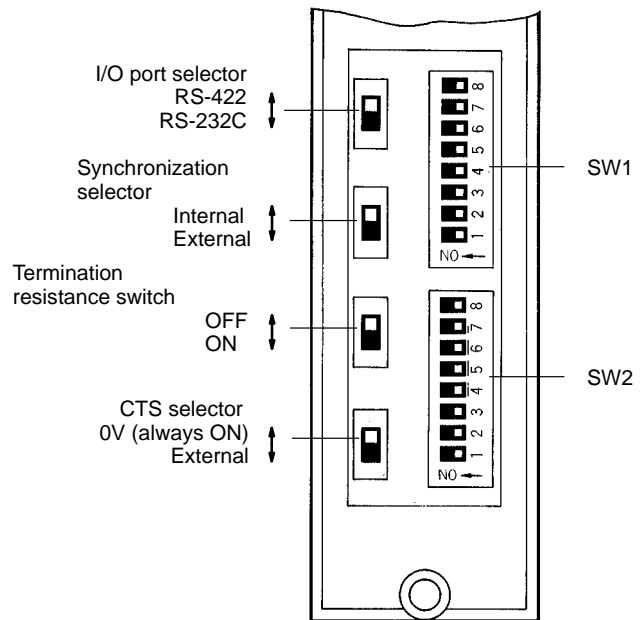
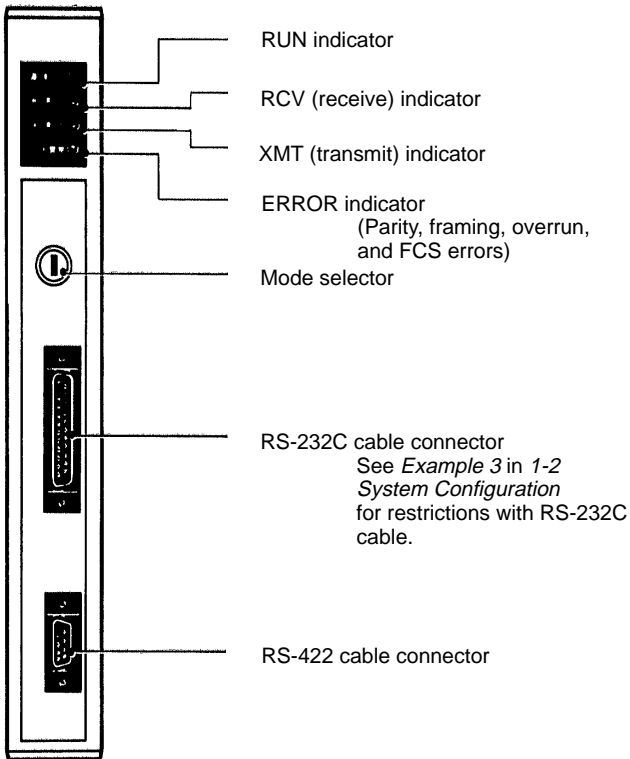

C500-LK203

C500-LK203

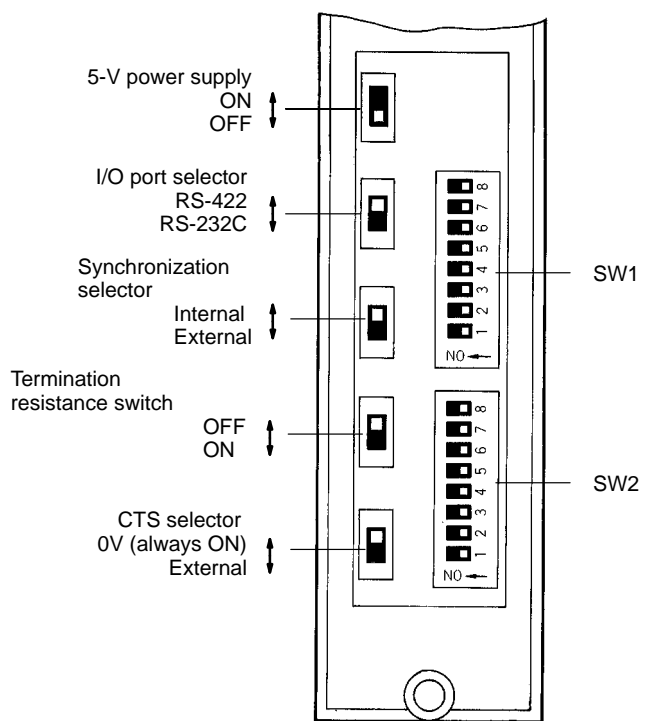
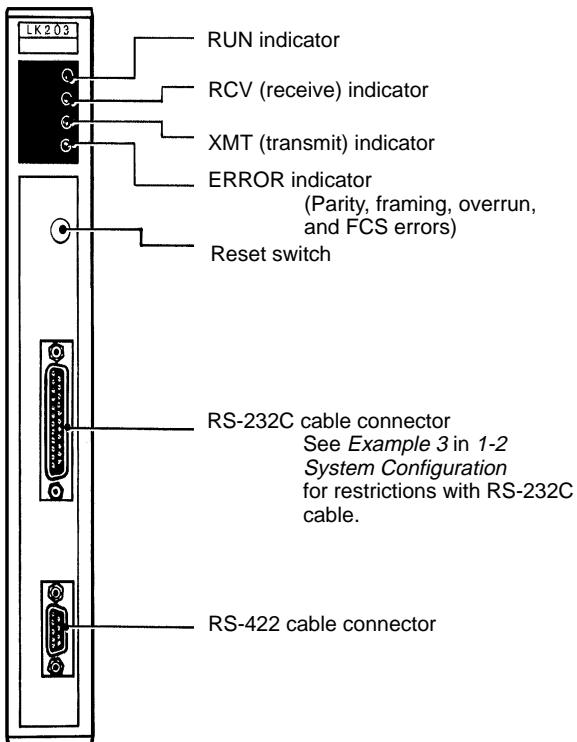

## 2-2-2 Switch Settings

The following information provides details on correct settings for the range of Host Link Units covered by this manual. Pay particular attention to the RUN/STOP and MONITOR/NORMAL switches on the C1000H-style cards.

### SW1

SW1 will perform one of two different functions depending on the Unit. In both instances, the first five pins are used to set the Unit number as shown below. Details about SW1 and SW2 settings are included following the diagram.

#### SW1 C500-LK103(-P)-LK203 and 3G2A5-LK101(-P)EV1/-LK201-EV1 Host Link Units

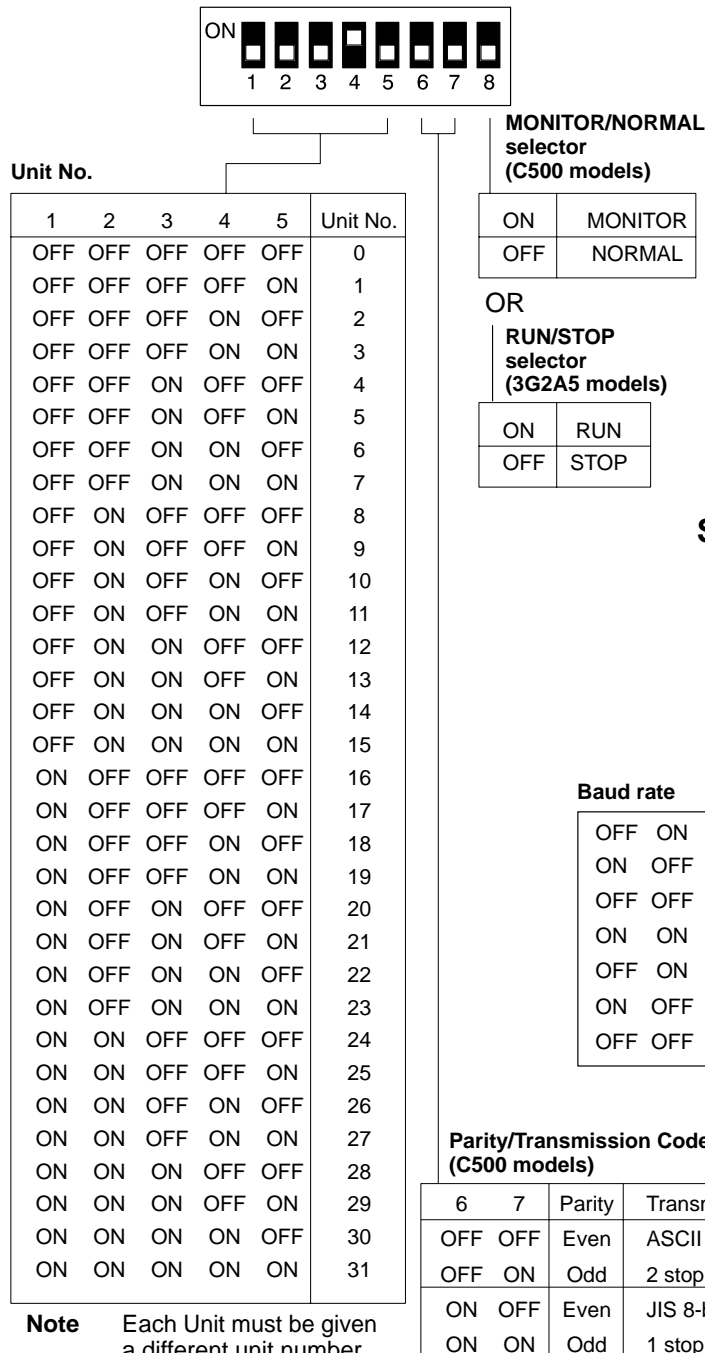

#### SW2 C500-LK103(-P))/LK203 and 3G2A5-LK101(-P)EV1/-LK201-EV1 Host Link Units

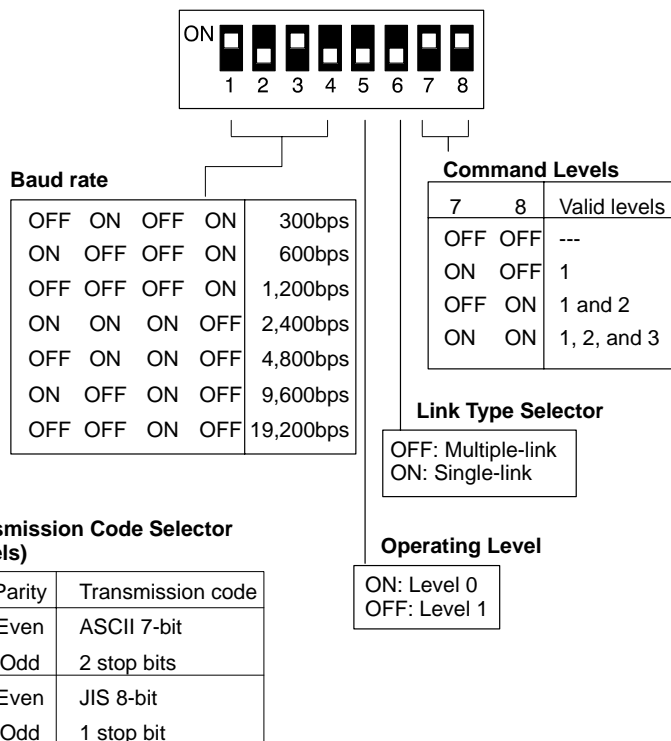

**Note** Each Unit must be given a different unit number.

**RUN/STOP Selector  
(3G2A5-LK101/-LK201)**

When pin 8 is set to RUN (ON), the CPU will start in RUN mode upon power application. When set to STOP (OFF), the CPU will start operation in PROGRAM mode. (Refer to to the *2-2-4 PC Operation Mode* for further details.)

**MONITOR/NORMAL  
Selector (C500-LK103(-P),  
C500-LK203)**

When pin 8 is set to MONITOR (ON), the PC will operate in MONITOR mode upon the application of power. When the pin is set to NORMAL (OFF), the PC is no longer controlled by the Host Link Unit (i.e., the mode of operation will be determined by other system conditions). Refer to the *2-2-4 PC Operating Mode* for details.

**SW2****Operating Level**

Set pin 5 of SW2 to OFF (operating level 1) when using a C500 PC and ON (operating level 0) when using the Host Link Unit together with a SYSMAC NET Link Unit. When using two Rack-mounting Host Link Units, set this pin to ON for one of the Units, and to OFF for the other.

**Caution**

Failure to set pin 5 correctly may damage components or prevent operation.

**Link Type Selector****ON (Single-link)**

If pin 6 is set to ON, the Host Link Unit is connected to the host computer on a one-to-one basis (see *Example 3* under *1-2 System Configuration*). The Unit number and Frame Checksum (FCS) settings are not required. The normal setting is OFF (see below).

**OFF (Multiple-link)**

If pin 6 is set to OFF, up to 32 Host Link Units can be connected to one host computer. The unit number and FCS must be specified, even if only one Host Link Unit is connected to the host computer. When using Ladder Support Software, LSS, pin 6 must be set to OFF.

**Command Levels**

1. Enables data areas to be read and, when the CPU has been correctly set via the SC (Status Write) command, data can also be written.
- 2: Enables program transfers and reading or writing of I/O tables.
- 3: I/O reads can be performed and I/O tables can be registered. The Command Level should be set to 1, 2, and 3 for running LSS software, program transfers, etc. Other levels may be used for Systems Control Software, monitoring, Data Acquisition Software, etc.

**Note** Commands valid for each level are listed in *3-1 Command Levels*.

**Mode Selector**

The Mode Selector (3G2A5-LK101/201) sets the Host Link Unit in to HOST or LOCAL mode. In HOST mode, the host computer can set the operating mode of the PC or write data to its memory. In LOCAL mode, the operating mode is specified by a programming device connected to the PC; such as a Programming Console. This switch is locked by removing the key with the HOST mode selected. See *2-2-4 PC Operating Mode* for further details.

**Reset Switch**

By pressing the Reset Switch the Host Link Unit is forced to the initial status.

**Synchronization Selector**

Sets the Host Link Unit to either an internal or external clock. Normally, an internal clock is employed. But, when a synchronization modem with a baud rate of 2,400 bps or higher is used, the external clock setting must be selected.

## Termination Resistance

When this switch is set to ON, a built-in termination resistance of  $220\ \Omega$  is connected. When set to OFF, the termination resistance is disconnected. When using a RS-422 cable throughout a system, the Host Link Unit at each end of the cable system must have the termination resistances connected by turning ON the switch as detailed in the following diagram. RS-232C systems provide point-to-point connections and do not require a termination resistance.

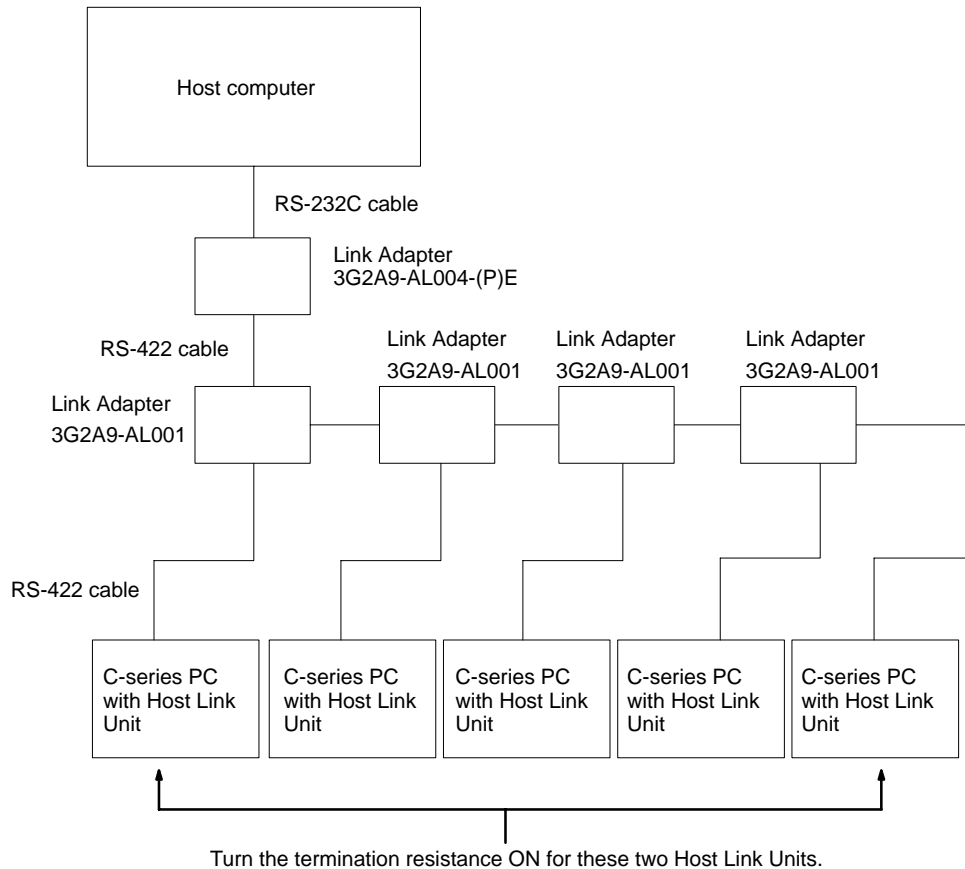

## CTS Selector

When the selector is set to 0 V, the clear-to-send (CTS) signal is continuously ON. When the selector is set to external, the Unit will respond to externally generated CTS signals. This is normally set to CTS always ON, i.e., the switch is set to ON.

## 5-V Power Supply Switch

When using a Z3RN-A-5 Optical Interface, the 5 V power supply switch should be set to ON; otherwise it should be set to OFF.

## I/O Port Selector

Sets the Host Link Unit (3G2A5-LK201-EV1 or C500-LK203) to either the RS-232C or the RS-422 interface.

### 2-2-3 Indicators

Indicator	Function
RUN	ON when the Unit is operating.
RCV	ON when the Host Link Unit is receiving data.
XMT	ON when the Host Link Unit is transmitting data.
ERROR	Goes ON when a transfer error is detected (See note 1.); goes OFF when a new command is received normally.

- Note**
- Transfer errors include parity, framing, overrun, and FCS errors.
  - Refer to *5-4 Troubleshooting* for details on correcting the following problems.
    - The RUN indicator does not light.
    - The Host Link Unit's RCV indicator does not light when data is transmitted from the host computer.
    - The RCV indicator lights, but the XMT indicator does not.
    - The ERROR indicator lights.
    - The XMT indicator lights, but the host computer does not receive the data.

### 2-2-4 PC Operating Modes

The operating mode of the PC depends on the setting of the mode selector on the Host Link Unit, the RUN/STOP or MONITOR/NORMAL selector on the Host Link Unit, and the status of any peripheral device connected to the PC. Refer to the following tables for details.

#### Host Link Units in C500, C1000H, or C2000H Systems (Except C500-LK103(-P) and C500-LK203 Host Link Units)

For Rack-mounting Host Link Units set to Host mode, the PC mode on initial application of power is as set on the Host Link Unit, i.e., RUN if the setting is RUN, and PROGRAM if the setting is STOP. (RUN/STOP setting is selected via pin 8 of DIP switch 1 for all models.) If the Host Link Unit is set to LOCAL, start-up mode will be as shown below.

System configuration and Host Link Unit setting*	Rack-mounting Host Link Unit in LOCAL mode	
No CPU-mounting device	RUN	
With CPU-mounting Host Link Unit	RUN	RUN
	STOP	PROGRAM
With CPU-mounting peripheral device	PROGRAM	
With Programming Console**	The mode is determined by the mode selector on the Console, i.e., RUN, MONITOR or PROGRAM.	

\* If there is no Rack-mounting Host Link Unit mounted, the data for the Rack-mounting Host Link Unit LOCAL mode applies.

\*\* With the Host Link Unit mode set to HOST, a MODE SET ERR alarm occurs if the Programming Console is set to MONTR or PROG and RUN is selected on the DIP switch, or if the Programming Console is set to RUN or MONTR with STOP selected.

The operating mode can be set from a host computer as long as the Host Link Unit is set to HOST mode. If the Host Link Unit is set to LOCAL mode, the operating mode cannot be set from the host computer and must be set from the host computer and must be set from a Peripheral Device, such as the Programming Console.

**C500-LK103(-P) and C500-LK203 Host Link Units**

System configuration and Host Link Unit setting		Host Link Unit mode	
		MONITOR	NORMAL
No other mounted device		MONITOR	RUN
Programming Console		The mode is determined by the mode selector on the Console., i.e., RUN, MONITOR, or PROGRAM.	
CPU-mounting Host Link Unit	RUN	*	RUN
	STOP	MONITOR	PROGRAM
Host Link Unit	MONITOR	MONITOR**	MONITOR**
	NORMAL	MONITOR**	RUN**
CPU-mounted peripheral device		MONITOR	PROGRAM

- \* A CPU-mounting Host Link Unit must be set to STOP mode when used together with a Rack-mounting Host Link Unit that is set to MONITOR mode.
- \*\* If a Programming Console is also mounted, the mode selector on the Programming Console determines the PC operating mode.

If a peripheral device other than a CPU-mounting Host Link Unit is attached to the CPU, the PC's operating mode is determined by the peripheral device when the Host Link Unit's mode selector is set for LOCAL. With the mode selector set for HOST, the PC's operating mode is determined by the RUN/STOP selector on the Host Link Unit.

Unless programming is implemented to prevent starting, if the PC is in RUN mode, it will begin operation immediately the power is applied. Refer to *Controlling PC Start-up* at the end of this subsection for details on programming methods. These methods do not apply when using a 3G2A5-LK101-(P)EV1 or 3G2A5-LK201-EV1 Host Link Unit.

**PC Mode When Mounting a CPU-mounting Host Link Unit with the Power ON**

System configuration			Rack-mounting Host Link Unit*	
			LOCAL	HOST
V1 PCs**			Operating mode unchanged	Operating mode unchanged
Other PCs	Mounting for the first time	RUN	RUN	
		STOP	PROGRAM	
	Remounting (the Host Link Unit has been mounted before)			

- \* If there is no Rack-mounting Host Link Unit mounted, data for the Rack-mounting Host Link Unit LOCAL mode applies.
- \*\* V1 PCs are the C200H/HS/HX/HG/HE, C1000H, C2000H, and any other building-block PC with the suffix "V1" in the model number.

**Data Flow**

**HOST Mode**

The following figures show the flow of data between the system and a Programming Console with the Host Link Unit set in HOST mode. As can be seen, the Programming Console can be used for monitoring or writing in this mode.

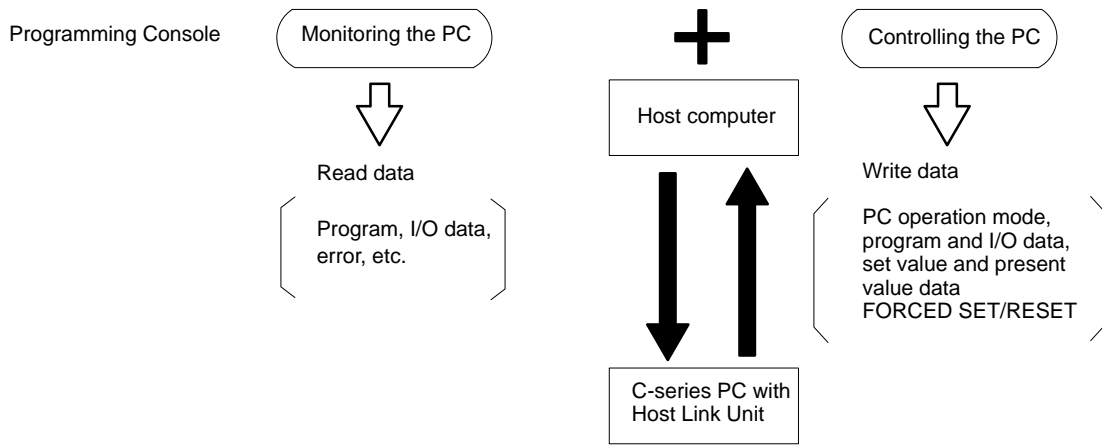

**LOCAL Mode**

The following diagram shows the flow of data while the Host Link Unit is in LOCAL mode. Note that in this mode the Programming Console can be used for monitoring only.

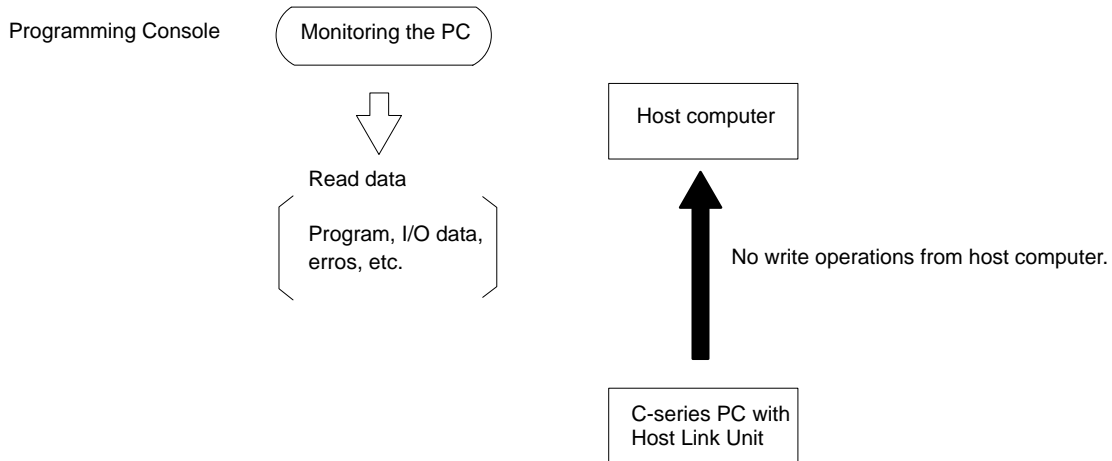

**C500-LK103(-P) and C500-LK203 Host Link Unit Modes**

These Units do not have mode selectors, i.e., PC operating modes can be set, data can be written, and similar operations can be performed without regard to HOST/LOCAL mode settings. Data flow is the same as that for HOST mode, shown above.

**Controlling PC Start-up**

**C500-LK103(-P) and C500-LK203 Host Link Units**

PROGRAM mode cannot be achieved manually when these Rack-mounting Host Link Units are used without a Programming Console or other peripheral device. Programming can be implemented, however, to prevent the PC from automatically starting when the power is applied. This allows greater control and the Unit can be started later with a command from the host computer. The following is an example of a programmed start-up of a C1000H PC.

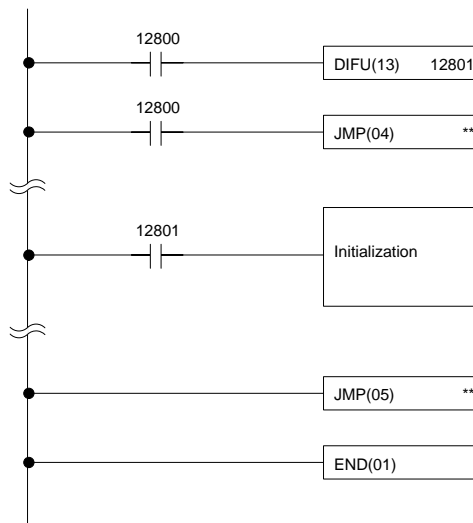

Appropriate initialization codes must be programmed between JMP(04) and JME(05). IR area bit 12800 can then be turned on to start PC operation from the host computer. The PC must be set in MONITOR mode for this to be possible. To initialize the PC when starting operation, use DIFU with the Always ON Flag; the Reset Flag cannot be used. Refer to your PC's operation manual for specific bits. The PC's operating mode can then be changed from the host computer after operation has begun. When programming in this fashion, note the following conditions:

- 1, 2, 3...**
1. Pin 8 of SW1 on C500-LK103(-P) or C500-LK203 Units should be set to MONITOR. If it is not, use the host computer to change it to the MONITOR mode before turning on IR area bit 12800.
  2. JMP command numbers must be between 01 and 99 for C200H/HS, C1000H and C2000H PCs.
  3. This programming example cannot be applied to C500 PCs, which do not support direct jumps. In this case, use a 3G2A5-LK101(-P)EV1 or 3G2A5-LK201-EV1 Host Link Unit so that the mode can be set manually.

### Sending a RUN Start Command to the PC

The following flowcharts show the computer decision making processes for ensuring that the PC is in RUN mode after start-up.

#### 3G2A5-LK101-(P)EV1 and 3G2A5-LK201-EV1 Host Link Units

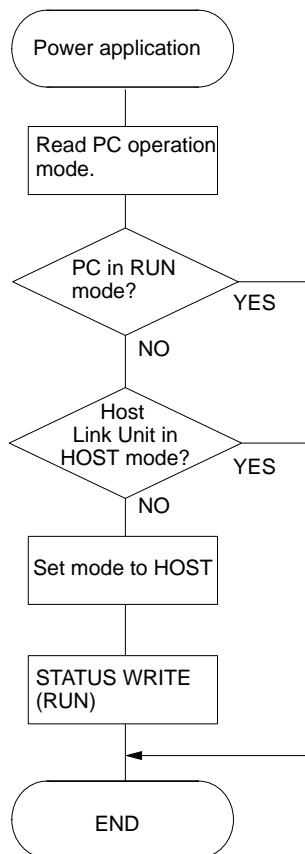

#### C500-LK103(-P) and C500-LK203 Host Link Units

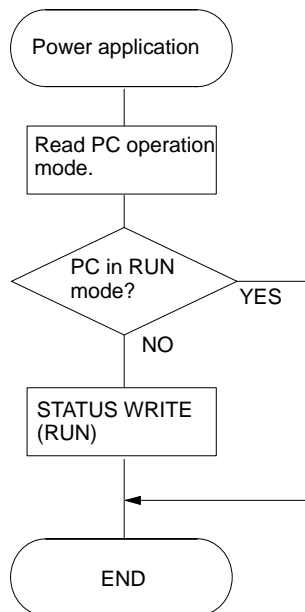

## 2-2-5 Restart Bits and Error Flags

Host Link Units use some of the Special Relay (SR) area and Auxiliary Relay (AR) area bits of the PC to restart the communications control program of the Host Link Unit and to indicate the occurrence of communications errors between the Unit and the computer. The word (Wd) addresses and bit numbers of these bits are as follows:

### C500

	Bit 15	Bit 14	Bit 13	Bit 12	Bit 11	Bit 10	Bit 9	Bit 8	Bit 7	Bit 6	Bit 5	Bit 4	Bit 3	Bit 2	Bit 1	Bit 0
SR Wd 60			RM* re-start bit				CM* restart bit	CM* error flag								
SR Wd 61					RM* error flag											

\* RM: Rack-mounting Host Link Unit  
 CM: CPU-mounting Host Link Unit

### C1000H and C2000H

	Bit 15	Bit 14	Bit 13	Bit 12	Bit 11	Bit 10	Bit 9	Bit 8	Bit 7	Bit 6	Bit 5	Bit 4	Bit 3	Bit 2	Bit 1	Bit 0
SR Wd 252			RM* re-start bit				CM* restart bit	CM* error flag		RM* #1 error flag						
SR Wd 253					RM* #0 error flag											

\* RM: Rack-mounting Host Link Unit  
 CM: CPU-mounting Host Link Unit

### C120

	Bit 15	Bit 14	Bit 13	Bit 12	Bit 11	Bit 10	Bit 9	Bit 8	Bit 7	Bit 6	Bit 5	Bit 4	Bit 3	Bit 2	Bit 1	Bit 0
SR Wd 60							CM* restart bit	CM* error flag								

\* CM: CPU-mounting Host Link Unit

### Host Link Unit Restart Bit

When this bit is turned ON, the Host Link Unit is reset to its initial conditions, as if the power had just been applied.



**Caution** Do not turn this bit ON in the user program; doing so could cause the memory to be lost.

### Host Link Unit Error Flag

This flag turns ON if a transmission error occurs between the PC and the Host Link Unit. It turns ON the error indicator on the front of the Unit.

**Note** 1. When the Host Link Unit Restart bit is turned ON, the Host Link Unit Error Flag is turned OFF.

2. Set the Host Link Unit to LOCAL mode before force setting or force resetting an error flag.
3. Communications between the Host Link Unit and the host computer will not be resumed until the Restart bit is turned OFF. The initialization process is repeated as long as the Restart bit is ON.

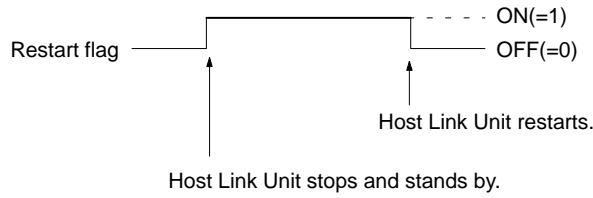

4. If a reset switch is provided, pressing it should reset the Host Link Unit and clear the error state.
5. If the Unit still won't reset, disconnect and then reconnect the power to the PC.

### 2-2-6 I/O Response Time

The processing that determines and the methods for calculating the minimum and maximum times required from an input on one PC with a Host Link Unit to an output on another PC with a Host Link Unit are described below. The transfer between the PCs is handled through a host computer connected to both these PCs.

Processing and calculations are described by PC model in the first subsection. An example combining a C200H/HS/HX/HG/HE PC with a C1000H PC is included in the C200H section. Although more precise equations may be written if required, those used in the following calculations do not consider fractions of a cycle.

The calculations used in this section assume that all host computer commands and PC responses require no more than one host link servicing period to complete transmission. To compute response times for situations involving a longer command and/or response, the number of host link servicing periods (i.e., the number of cycles) required to complete the command or response would have to be incorporated into the equations.

In considering response times, it is important to remember the sequence of processing that occurs during the PC cycle. The main factor that affects the response time is the timing of inputs and outputs and of host computer processing in relation to this sequence.

The following diagram illustrates the setup used in response time calculations

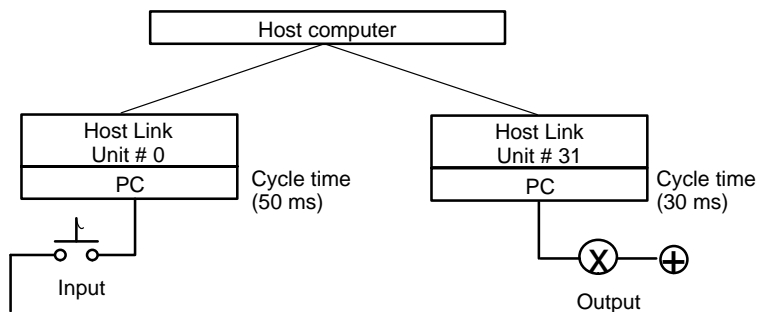

### C120 and C500

Although the C120 and C500 equations for the minimum and maximum response times are the same as those for the C1000H and C2000H, the break-

down of the CPU's cycle differs. These groups are thus treated in different sections.

**Minimum Response Time**

The data flow that will produce the minimum response time is shown below. This flow assumes that all signals and data transmissions are processed as soon as they occur. The equation for the minimum response time is given below the diagram.

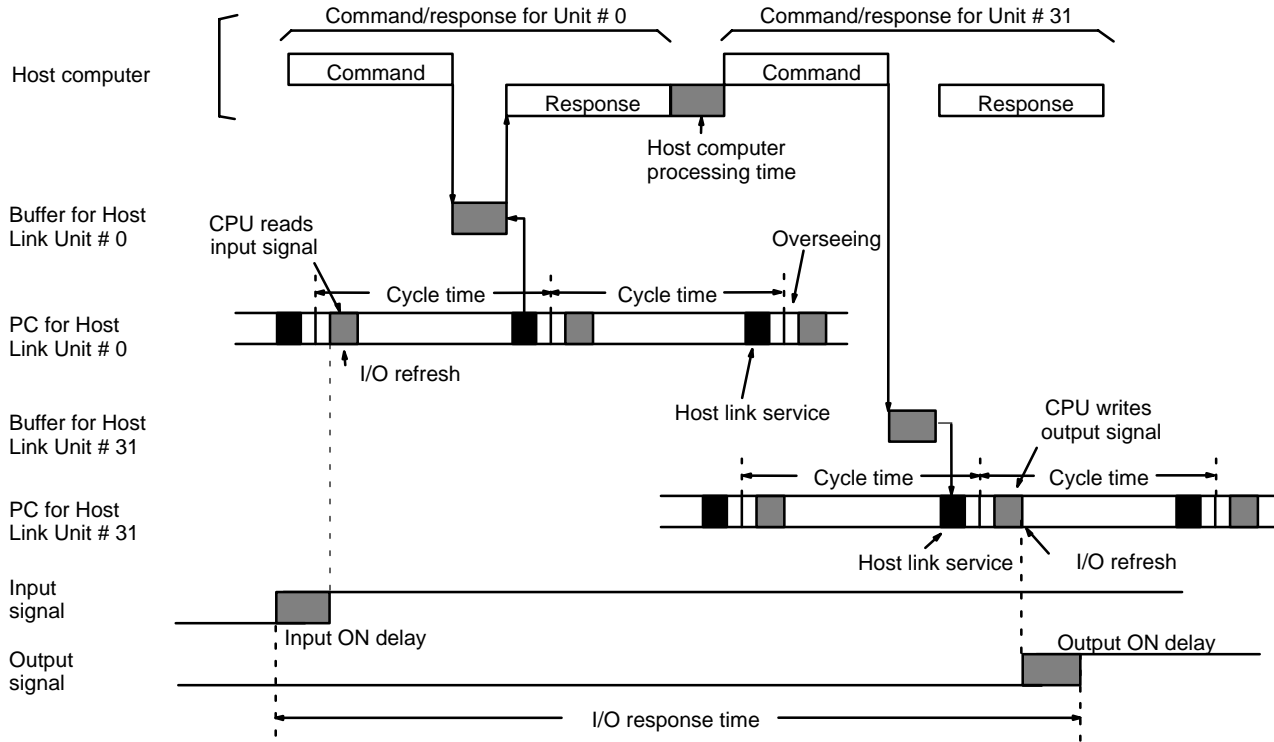

Minimum response time = Input ON delay + Command transmission time + Cycle time of PC for Unit #0 + Response transmission time + Host computer processing time + Command transmission time + Output ON delay

**Maximum Response Time**

The data flow that will produce the maximum response time is shown below. Delays over the minimum response time occur because the input to be transferred through the host computer is received immediately following the I/O refresh period (requiring a wait to the next cycle) and because the command from the host computer to write the bit to be output from PC for Unit #31 is received immediate-

ly following host link servicing (again requiring a wait to the next cycle). The equation for the maximum response time is given below the diagram.

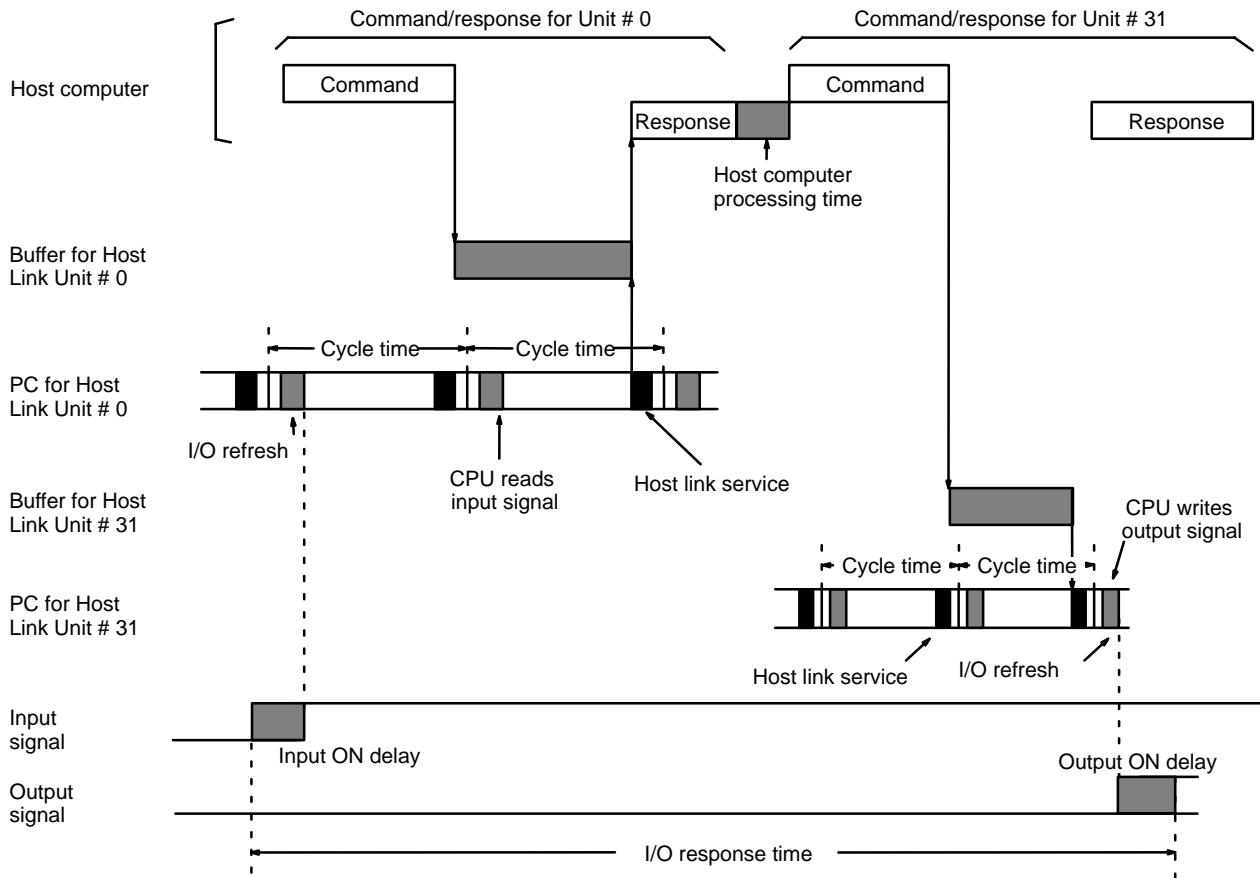

Maximum response time = Input ON delay + Command transmission time + (Cycle time of PC for Unit #0 x 2) + Response transmission time + Host computer processing time + Command transmission time + Cycle time of PC for Unit #31 + Output ON delay

**C1000H and C2000H**

Although the C1000H and C2000H equations for the minimum and maximum response times are the same as those for the 3G2A6 and C500, the breakdown of the CPU's cycle differs. These groups are thus treated in different sections.

**Minimum Response Time**

The data flow that will produce the minimum response time is shown below. This flow assumes that all signals and data transmissions are processed as soon as they occur. The equation for the minimum response time is given below the diagram.

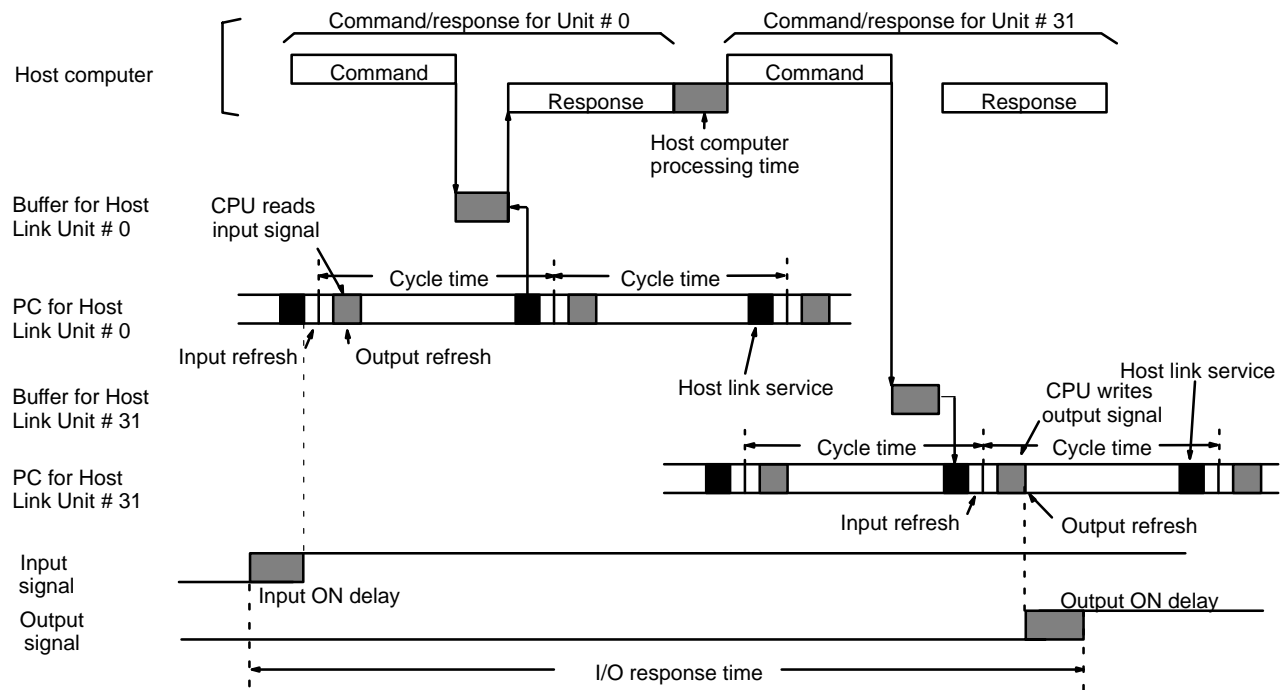

Minimum response time = Input ON delay + Command transmission time + Cycle time of PC for Unit #0 + Response transmission time + Host computer processing time + Command transmission time + Output ON delay

**Maximum Response Time**

The data flow that will produce the maximum response time is shown below. Delays over the minimum response time occur because the input to be transferred through the host computer is received immediately following the I/O refresh period (requiring a wait to the next cycle) and because the command from the host computer to write the bit to be output from PC for Unit #31 is received immediately following host link servicing (again requiring a wait to the next cycle). The equation for the maximum response time is given below the diagram.

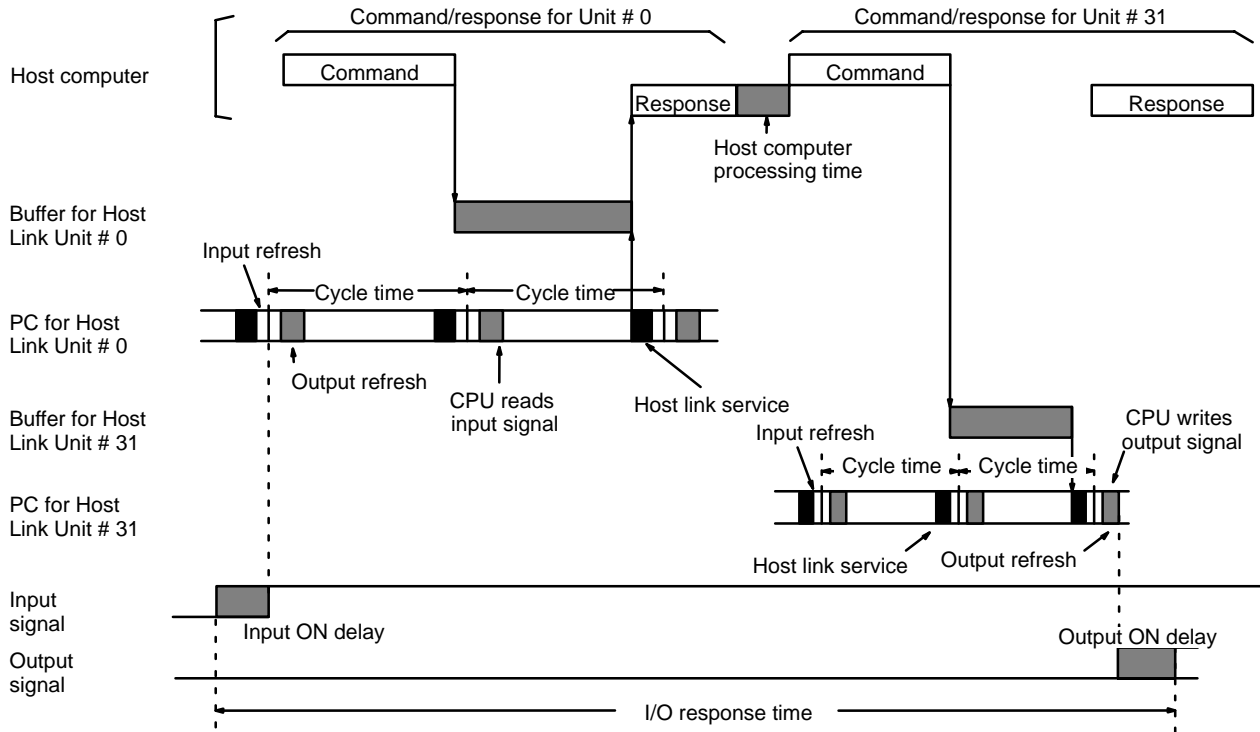

Maximum response time = Input ON delay + Command transmission time + (Cycle time of PC for Unit #0 x 2) + Response transmission time + Host computer processing time + Command transmission time + Cycle time of PC for Unit #31 + Output ON delay

## 2-3 C120 (3G2A6) Host Link Units

### 2-3-1 Nomenclature and External Appearance

The following figures give details of switch types, selectors, and connectors for your Host Link Unit. It will be necessary to refer to these diagrams from time to time as you read further in the manual, particularly when reading the section on *2-3-2 Switch Settings*. These Units can be used with all of the C-series Rack-mounting PCs. (C120 Host Link Units are sometimes referred to as 3G2A6 Host Link Units.)

#### Front Panels

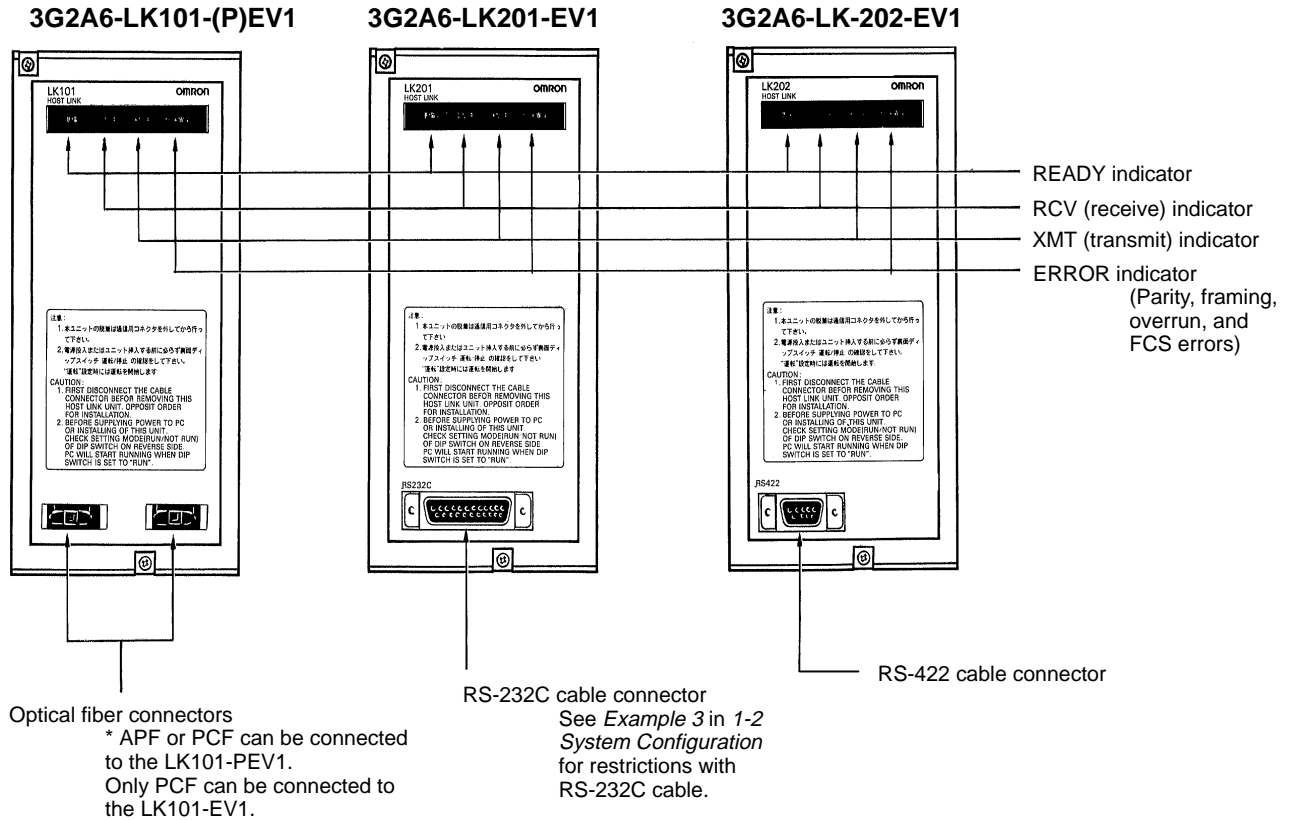

#### Rear Panels

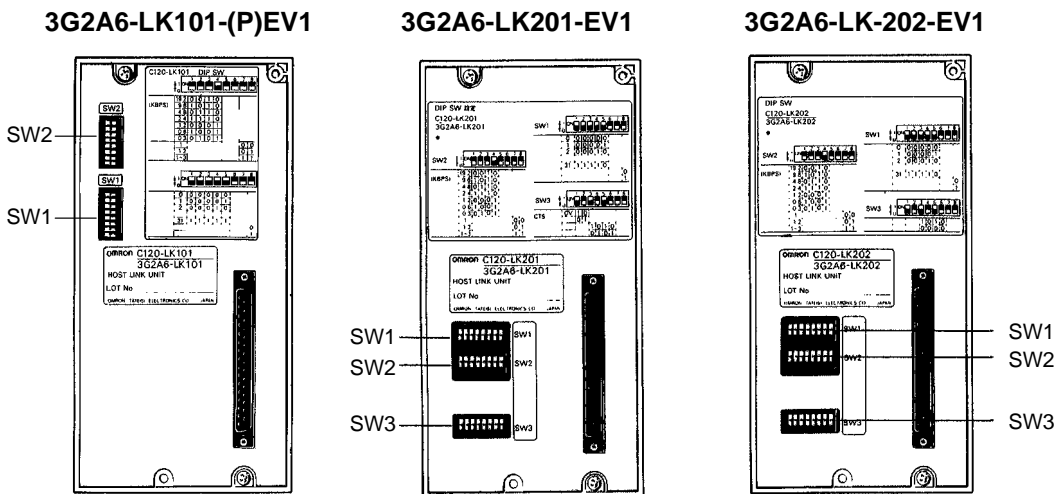

## 2-3-2 Switch Settings

The following information provides details on correct settings for the range of 3G2A6 Host Link Units covered by this manual.

### SW1

For SW1, the first five pins are used to set the Unit number as shown below. Details about SW2 settings are given following the diagram.

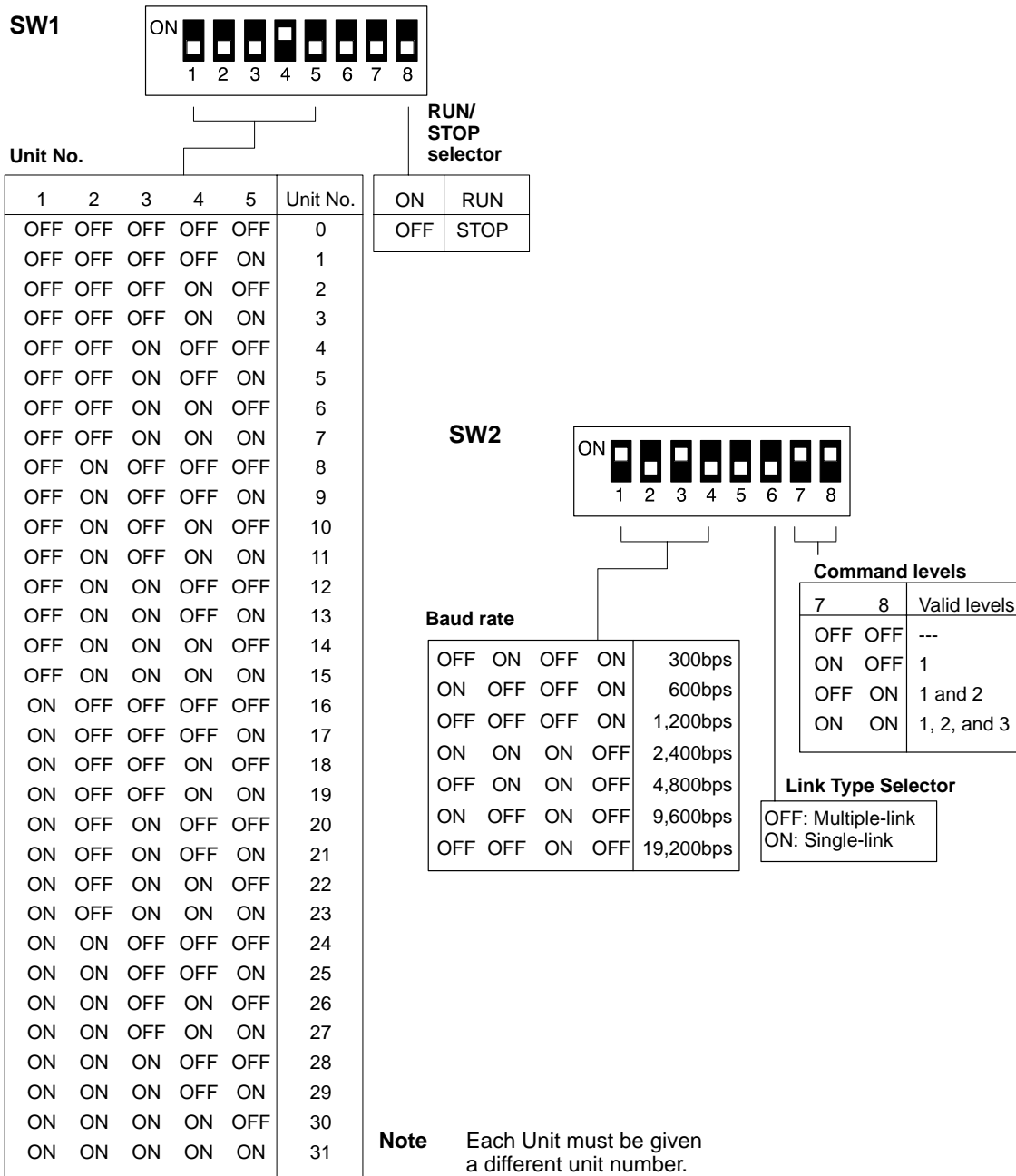

**RUN/STOP Selector**

Refer to 2-3-4 PC Operating Modes for details.

**SW2**

**Operating Levels**

Set pin 5 of SW2 to OFF (operating level 1) when using a C500(F) PC and ON (operating level 0) when using the Host Link Unit together with a SYSMAC NET Link Unit. When using two Rack-mounting Host Link Units, set this pin to ON for one of the Units, and to OFF for the other.

**Caution** Failure to set pin 5 correctly may damage components or prevent operation.

**MONITOR/NORMAL Selector**

When this switch is set to MONITOR, the PC will operate in MONITOR mode upon the application of power. When the pin is set to NORMAL, the PC is no longer controlled by the Host Link Unit (i.e., the mode of operation will be determined by other system conditions). Refer to 2-3-4 PC Operating Mode for details.

**Link Type Selector**

**ON (Single-link)** If pin 6 is set to ON, the Host Link Unit is connected to the host computer on a one-to-one basis (see Example 3 and Example 5 under 1-2 System Configuration. The Unit number and Frame Checksum (FCS) settings are not required. The normal setting is OFF (see below).

**OFF (Multiple-link)** If pin 6 is set to OFF, up to 32 Host Link Units can be connected to one host computer. The unit number and FCS must be specified, even if only one Host Link Unit is connected to the host computer. When using Ladder Support Software, LSS, pin 6 must be set to OFF.

**Command Level**

Pins 7 and 8 on SW2 control the operating command levels according to the following:

- 1: Enables data areas to be read and, when the CPU has been correctly set via the SC (Status Write) command, data can also be written.
- 2: Enables program transfers and reading or writing of I/O tables.
- 3: I/O reads can be performed and I/O tables can be registered. The Command Level should be set to 1, 2, and 3 for running LSS software, program transfers, etc. Other levels may be used for Systems Control Software, monitoring, Data Acquisition Software, etc.

**Note** Commands valid for each level are listed in 3-1 Command Levels.

**SW3**

3G2A6-LK201-EV1

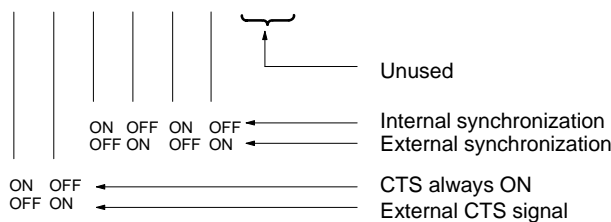
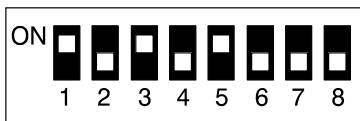

3G2A6-LK202-EV1

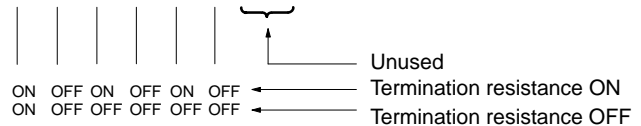
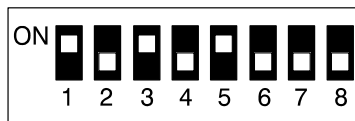

**Synchronization Selector**

Sets the Host Link Unit to either an internal or external clock. Normally, an internal clock is employed. But, when a synchronization modem with a baud rate of 2,400 bps or higher is used, the external clock setting must be selected.

**Termination Resistance**

When this switch is set to ON, a built-in termination resistance of 220 Ω is connected. When set to OFF, the termination resistance is disconnected. When using a RS-422 cable throughout a system, the Host Link Unit at each end of the cable system must have the termination resistances connected by turning ON the switch as detailed in the following diagram. RS-232C systems provide point-to-point connections and do not require a termination resistance.

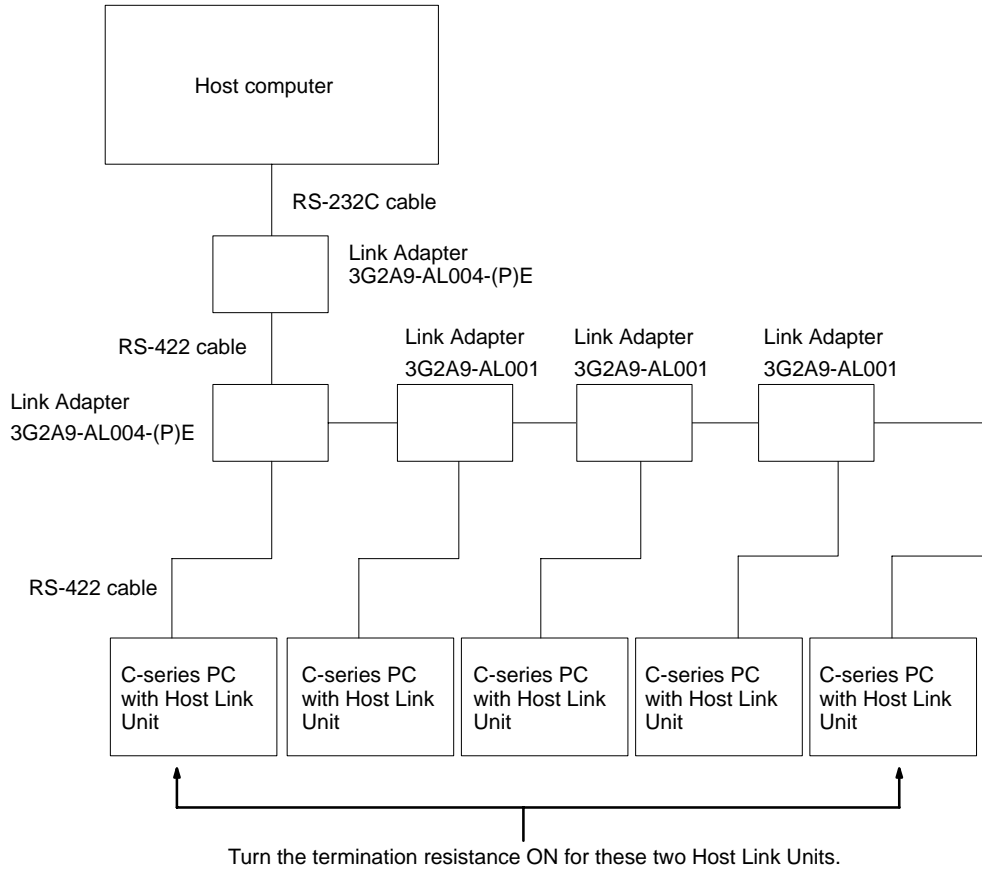

**CTS Selector**

When the selector is set to 0 V, the clear-to-send (CTS) signal is continuously ON. When the selector is set to external, the Unit will respond to externally generated CTS signals. This is normally set to CTS always ON, i.e., the switch is set to ON.

**2-3-3 Indicators**

Indicator	Function
Ready	ON when the power is on and the Unit is ready to transmit.
RCV	ON when the Host Link Unit is receiving data.
XMT	ON when the Host Link Unit is transmitting data.
ERROR	Goes ON when a transfer error is detected (See note 1.); goes OFF when a new command is received normally.

- Note**
1. Transfer errors include parity, framing, overrun, and FCS errors.
  2. Refer to *5-4 Troubleshooting* for details on correcting the following problems.
    - The RUN indicator does not light.
    - The Host Link Unit's RCV indicator does not light when data is transmitted from the host computer.
    - The RCV indicator lights, but the XMT indicator does not.
    - The ERROR indicator lights.
    - The XMT indicator lights, but the host computer does not receive the data.

## 2-3-4 PC Operating Modes

The operating mode of the PC depends on the setting of the mode selector on the Host Link Unit, the RUN/STOP or MONITOR/NORMAL selector on the Host Link Unit, and the status of any peripheral device connected to the PC. Refer to the following tables for details.

### C500-LK103(-P), C500-LK203, and 3G2A6 Host Link Units

System configuration and Host Link Unit setting		Host Link Unit mode	
		MONITOR	NORMAL
No other mounted device		MONITOR	RUN
Programming Console		The mode is determined by the mode selector on the Console., i.e., RUN, MONITOR, or PROGRAM.	
CPU-mounting Host Link Unit	RUN	*	RUN
	STOP	MONITOR	PROGRAM
Host Link Unit	MONITOR	MONITOR**	MONITOR**
	NORMAL	MONITOR**	RUN**
CPU-mounted peripheral device		MONITOR	PROGRAM

\* A CPU-mounting Host Link Unit must be set to STOP mode when used together with a Rack-mounting Host Link Unit that is set in MONITOR mode.

\*\* If a Programming Console is also mounted, the mode selector on the Programming Console determines the PC operating mode.

If a peripheral device other than a CPU-mounting Host Link Unit is attached to the CPU, the PC's operating mode is determined by the peripheral device when the Host Link Unit's mode selector is set for LOCAL. With the mode selector set for HOST, the PC's operating mode is determined by the RUN/STOP selector on the Host Link Unit.

Unless programming is implemented to prevent starting, if the PC is in RUN mode, it will begin operation immediately the power is applied. Refer to *Controlling PC Start-up* at the end of this subsection for details on programming methods.

### PC Mode When Mounting a CPU-mounting Host Link Unit with the Power ON

System configuration			Rack-mounting Host Link Unit*	
			LOCAL	HOST
V1 PCs**			Operating mode unchanged	Operating mode unchanged
Other PCs	Mounting for the first time	RUN	RUN	Operating mode unchanged
		STOP	PROGRAM	
	Remounting (the Host Link Unit has been mounted before)	Operating mode unchanged		

\* If there is no Rack-mounting Host Link Unit mounted, data for the Rack-mounting Host Link Unit LOCAL mode applies.

\*\* V1 PCs are the C200H/HS/HX/HG/HE, C1000H, C2000H, and any other building-block PC with the suffix "V1" in the model number.

**Caution Sticker**

The CPU-mounting 3G2A6-LK101-(P)EV1 Host Link Unit is supplied with a caution sticker. The caution sticker should be attached as shown below if the RUN/STOP selector is set to RUN. This is to avoid the potential danger of the Host Link Unit being mounted to an unprepared system.

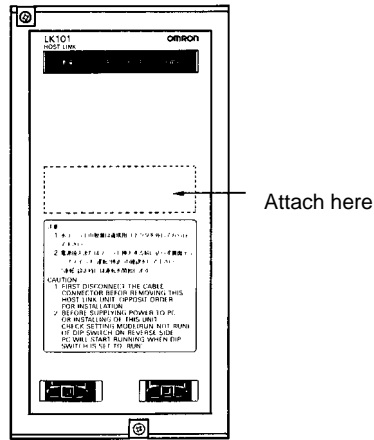

**Sending a RUN Start Command to the PC**

The following flowchart shows the computer decision making processes for ensuring that the PC is in RUN mode after start-up.

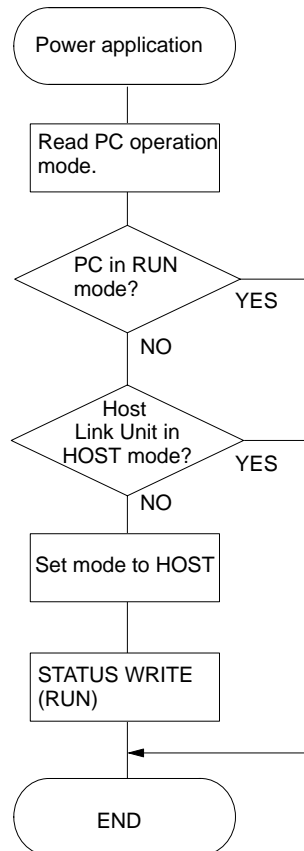

## 2-3-5 Restart Bits and Error Flags

Host Link Units use some of the Special Relay (SR) area and Auxiliary Relay (AR) area bits of the PC to restart the communications control program of the Host Link Unit and to indicate the occurrence of communications errors between the Unit and the computer. The word (Wd) addresses and bit numbers of these bits are as follows:

### C120 (3G2A6)

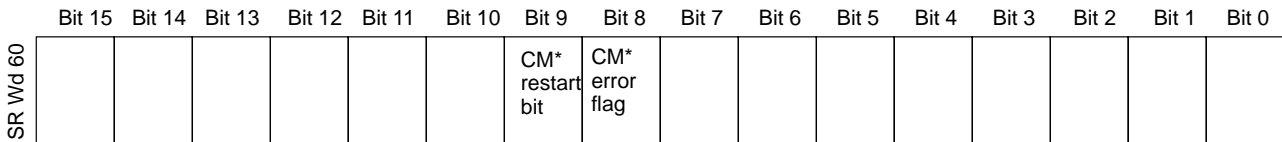

\* CM: CPU-mounting Host Link Unit

### Host Link Unit Restart Bit

When this bit is turned ON, the Host Link Unit is reset to its initial conditions, as if the power had just been applied.

**Caution** Do not turn this bit ON in the user program; doing so could cause the memory to be lost.

### Host Link Unit Error Flag

This flag turns ON if a transmission error occurs between the PC and the Host Link Unit. The error indicator on the front panel of the Unit lights while this flag is ON.

- Note**
1. When the Host Link Unit Restart bit is turned ON, the Host Link Unit Error Flag is turned OFF.
  2. Set the Host Link Unit to LOCAL mode before force setting or force resetting an error flag.
  3. Communications between the Host Link Unit and the host computer will not be resumed until the Restart bit is turned OFF. The initialization process is repeated as long as the Restart bit is ON.

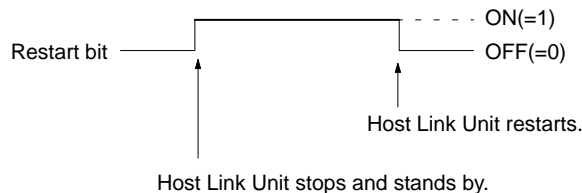

4. To reset error condition on the Host Link Unit, disconnect and then reconnect the power to the PC.

### 2-3-6 I/O Response Time

The processing that determines and the methods for calculating the minimum and maximum times required from an input on one PC with a Host Link Unit to an output on another PC with a Host Link Unit are described below. The transfer between the PCs is handled through a host computer connected to both these PCs.

Processing and calculations are described by PC model. Although more precise equations may be written if required, those used in the following calculations do not consider fractions of a cycle.

The calculations used in this section assume that all host computer commands and PC responses require no more than one host link servicing period to complete transmission. To compute response times for situations involving a longer command and/or response, the number of host link servicing periods (i.e., the number of cycles) required to complete the command or response would have to be incorporated into the equations.

In considering response times, it is important to remember the sequence of processing that occurs during the PC cycle. The main factor that affects the response time is the timing of inputs and outputs and of host computer processing in relation to this sequence.

The following diagram illustrates the setup used in response time calculations

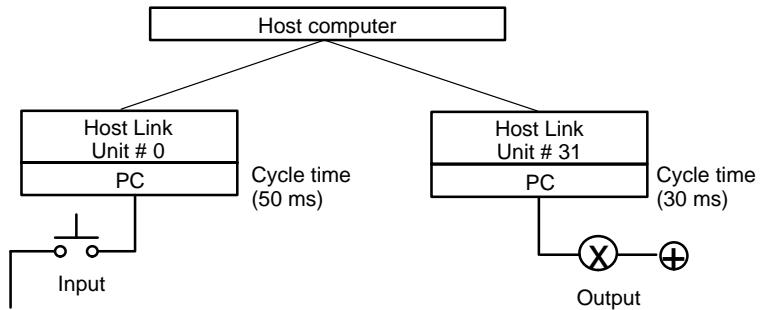



**Maximum Response Time**

The data flow that will produce the maximum response time is shown below. Delays over the minimum response time occur because the input to be transferred through the host computer is received immediately following the I/O refresh period (requiring a wait to the next cycle) and because the command from the host computer to write the bit to be output from PC for Unit #31 is received immediately following host link servicing (again requiring a wait until the next cycle). The equation for the maximum response time is given below the diagram.

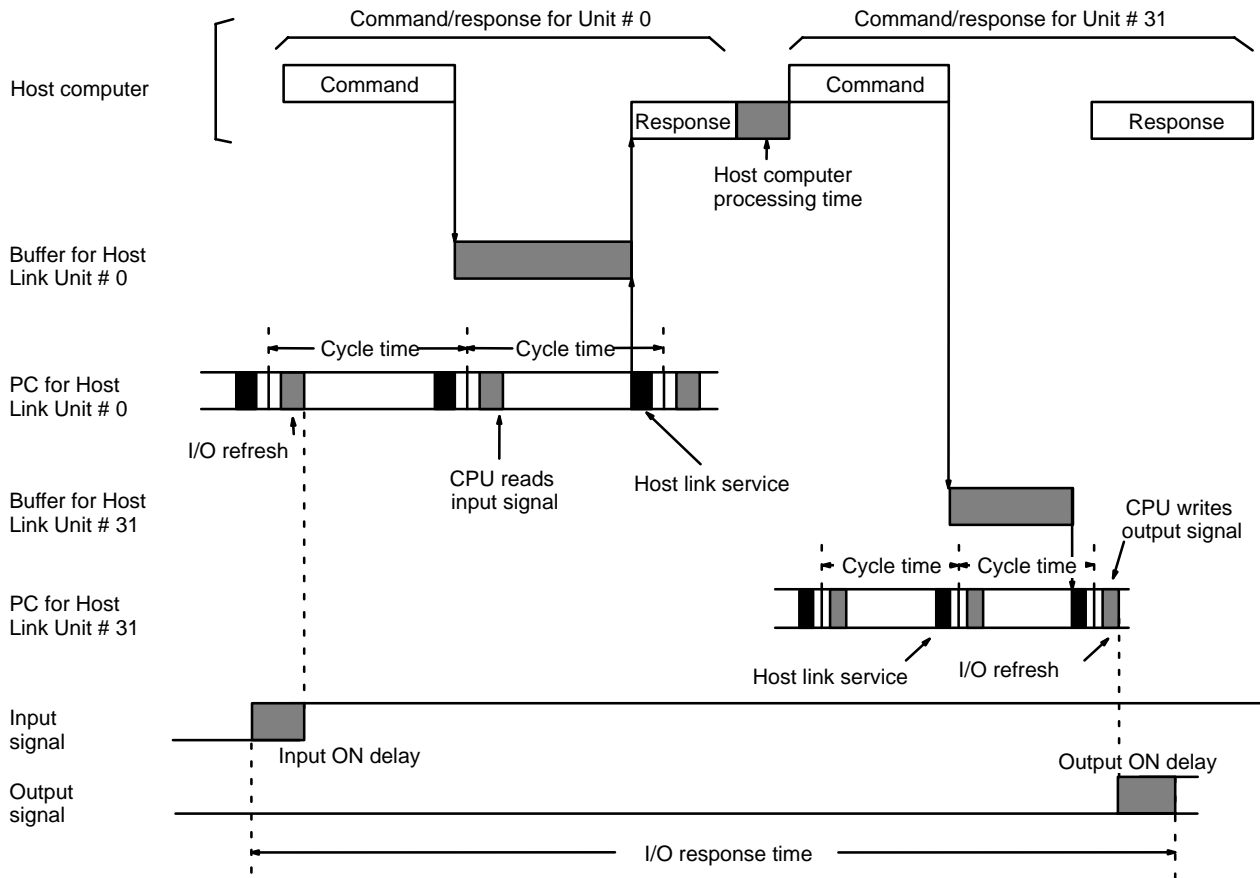

Maximum response time = Input ON delay + Command transmission time + (Cycle time of PC for Unit #0 x 2) + Response transmission time + Host computer processing time + Command transmission time + Cycle time of PC for Unit #31 + Output ON delay

## 2-4 Installing and Removing Host Link Units

This section explains the proper installation and removal of CPU-mounting Host Link Units.

**Note** Never install or remove Rack-mounting Host Link Units when the power supply is on.

**Installation of a CPU-mounting Host Link Unit**

Follow the procedure below when installing a CPU-mounting Host Link Unit on a PC.

- 1, 2, 3... 1. Remove the Connecting Cables.
2. Recheck the settings of the DIP switches on the back of the Unit. In particular, check the RUN/STOP switch. If the switch is set to RUN, the PC might begin operating when the Host Link Unit is inserted. The PC's mode will not change if the switch is set to STOP. Refer to 2-1-4 PC Operating Modes for details on the Host Link Unit's effect on the PC's mode.

3. Connect the Host Link Unit to the PC's Peripheral Device port and tighten the mounting screws.
4. Connect the Connecting Cable and tighten the mounting screws.

**Removal of CPU-mounting Host Link Units**

Follow the procedure below when removing a CPU-mounting Host Link Unit from a PC.

- 1, 2, 3...**
1. Remove the Connecting Cable.
  2. Remove the Host Link Unit.

**Transmission Errors**

When a CPU-mounting Host Link Unit is installed or removed during transmission, a transmission error will occur after removal if the host computer initiated communications with the affected Unit. The following table describes the appropriate procedure to follow.

<b>Event</b>	<b>Host Link Unit Indicator Status</b>	<b>Host Computer Status</b>	<b>Corrective Action</b>
Host Link Unit installed.	ERROR indicator lit.	Transmission error occurs.	Retransmit from the host computer.
Host Link Unit was removed.	---	Transmission error occurs.	Ignore the affected Host Link Unit's transmission error or reconfigure so that transmission to that Unit will not be attempted.
Host Link Unit has been removed.	---	Transmission error occurs.	Ignore the affected Host Link Unit's transmission error or reconfigure so that transmission to that Unit will not be attempted.

It is recommended to prepare a program that processes transmission errors in order to prevent an error with one Unit from stopping the entire system. Refer to *Section 5 Error Processing* for details.

# SECTION 3

## Programming

This section gives the information required for effective programming of the Host Link Units. It lists the commands and responses for Host Link Units. The basic formats for that they can take are described and the data representation explained. *3-1 Command Levels* lists all of the commands and responses which apply to Host Link Units and the operation level at which they operate. Also refer to *3-2 Communications Protocol* for basic format information (see also *Section 4 Commands and Responses* for the command and response formats of each instruction).

3-1	Command Levels .....
3-2	Communications Protocol .....
3-2-1	Block Format .....
3-2-2	Block Format With More Than One Frame .....
3-2-3	Data Representation .....
3-2-4	System Checks .....
3-2-5	Data Transaction Test Program .....
3-3	Communications Protocol (C200HS/HX/HG/HE only) .....
3-3-1	Command Timing .....
3-4	Frame Checksum (FCS) Calculation .....
3-4-1	FCS Calculation Program Example .....

## 3-1 Command Levels

The following tables give the commands and responses available for the Host Link Units, the command levels, and the modes in which they are applicable. Details of the command and response formats are given in *Section 4 Commands and Responses*.

### Level 1

Header Code	Name	PC Mode			Applicable PCs
		RUN	MNTR	PROG	
TS	TEST	Valid	Valid	Valid	All: C120, C200H/HS/HX/HG/HE, C500, C1000H, C2000H
MS	STATUS READ	Valid	Valid	Valid	All: C120, C200H/HS/HX/HG/HE, C500, C1000H, C2000H
MF	ERROR READ	Valid	Valid	Valid	All: C120, C200H/HS/HX/HG/HE, C500, C1000H, C2000H
RR	IR/SR AREA READ	Valid	Valid	Valid	All: C120, C200H/HS/HX/HG/HE, C500, C1000H, C2000H
RH	HR AREA READ	Valid	Valid	Valid	All: C120, C200H/HS/HX/HG/HE, C500, C1000H, C2000H
RJ	AR AREA READ	Valid	Valid	Valid	H-type: C200H/HS/HX/HG/HE, C1000H, C2000H
RL	LR AREA READ	Valid	Valid	Valid	All: C120, C200H/HS/HX/HG/HE, C500, C1000H, C2000H
RG	TC STATUS READ	Valid	Valid	Valid	All: C120, C200H/HS/HX/HG/HE, C500, C1000H, C2000H
RD	DM AREA READ	Valid	Valid	Valid	All: C120, C200H/HS/HX/HG/HE, C500, C1000H, C2000H
RX	FM INDEX READ	Valid	Valid	Valid	C1000H, C2000H
RF	FM DATA READ	Valid	Valid	Valid	C1000H, C2000H
RC	TC PV READ	Valid	Valid	Valid	All: C120, C200H/HS/HX/HG/HE, C500, C1000H, C2000H
R#	SV READ 1	Valid	Valid	Valid	All: C120, C200H/HS/HX/HG/HE, C500, C1000H, C2000H
R\$	SV READ 2	Valid	Valid	Valid	All: C120, C200H/HS/HX/HG/HE, C500, C1000H, C2000H
R%	SV READ 3	Valid	Valid	Valid	All: C120, C200H/HS/HX/HG/HE, C500, C1000H, C2000H
SC	STATUS WRITE	Valid	Valid	Valid	All: C120, C200H/HS/HX/HG/HE, C500, C1000H, C2000H
WR	IR/SR AREA WRITE	Not Valid	Valid	Valid	All: C120, C200H/HS/HX/HG/HE, C500, C1000H, C2000H
WH	HR AREA WRITE	Not Valid	Valid	Valid	All: C120, C200H/HS/HX/HG/HE, C500, C1000H, C2000H
WJ	AR AREA WRITE	Not valid	Valid	Valid	H-type: C200H(S), C1000H, C2000H

Header Code	Name	PC Mode			Applicable PCs
		RUN	MNTR	PROG	
WL	LR AREA WRITE	Not Valid	Valid	Valid	All: C120, C200H/HS/HX/HG/HE, C500, C1000H, C2000H
WG	TC STATUS WRITE	Not Valid	Valid	Valid	All: C120, C200H/HS/HX/HG/HE, C500, C1000H, C2000H
WD	DM AREA WRITE	Not Valid	Valid	Valid	All: C120, C200H/HS/HX/HG/HE, C500, C1000H, C2000H
WF	FM AREA WRITE	Not Valid	Valid	Valid	C1000H, C2000H
WC	TC PV WRITE	Not Valid	Valid	Valid	All: C120, C200H/HS/HX/HG/HE, C500, C1000H, C2000H
W#	SV CHANGE 1	Not Valid	Valid	Valid	All: C120, C200H/HS/HX/HG/HE, C500, C1000H, C2000H
W\$	SV CHANGE 2	Not Valid	Valid	Valid	All: C120, C200H/HS/HX/HG/HE, C500, C1000H, C2000H
W%	SV CHANGE 3	Not Valid	Valid	Valid	All: C120, C200H/HS/HX/HG/HE, C500, C1000H, C2000H
KS	FORCED SET	Not Valid	Valid	Valid	All: C120, C200H/HS/HX/HG/HE, C500, C1000H, C2000H
KR	FORCED RESET	Not Valid	Valid	Valid	All: C120, C200H/HS/HX/HG/HE, C500, C1000H, C2000H
FK	MULTIPLE FORCED SET/RESET	Not Valid	Valid	Valid	C200H/HS
FR	MULTIPLE FORCED SET/RESET STATUS READ	Not Valid	Valid	Valid	C200H/HS
KC	FORCED SET/RESET CANCEL	Not Valid	Valid	Valid	All: C120, C200H/HS/HX/HG/HE, C500, C1000H, C2000H
MM	PC MODEL READ	Valid	Valid	Valid	All: C120, C200H/HS/HX/HG/HE, C500, C1000H, C2000H
CR	DM AREA HIGH-SPEED READ	Valid	Valid	Valid	C1000H, C2000H
XZ	ABORT and INITIAL (command only)	Valid	Valid	Valid	All: C120, C200H/HS/HX/HG/HE, C500, C1000H, C2000H
IC	Undefined command (response only)	Valid	Valid	Valid	All: C120, C200H/HS/HX/HG/HE, C500, C1000H, C2000H
EX	TRANSMIT	Valid	Valid	Not valid	C200HS
Varies	Unprocessed command (response only)	Valid	Valid	Valid	All: C120, C200H/HS/HX/HG/HE, C500, C1000H, C2000H

Level 2

Header Code	Name	PC Mode			Applicable PCs
		RUN	MNTR	PROG	
RP	PROGRAM READ	Valid	Valid	Valid	All: C120, C200H/HS/HX/HG/HE, C500, C1000H, C2000H
WP	PROGRAM WRITE	Not valid	Not valid	Valid	All: C120, C200H/HS/HX/HG/HE, C500, C1000H, C2000H

Header Code	Name	PC Mode			Applicable PCs
		RUN	MNTR	PROG	
RI	I/O TABLE READ	Valid	Valid	Valid	All: C120, C200H/HS/HX/HG/HE, C500, C1000H, C2000H
MI	I/O TABLE GENERATE	Not valid	Not valid	Valid	All: C120, C200H/HS/HX/HG/HE, C500, C1000H, C2000H

Level 3

Header Code	Name	PC Mode			Applicable PCs
		RUN	MNTR	PROG	
QQ	COMPOUND COMMAND	Valid	Valid	Valid	All: C120, C200H/HS/HX/HG/HE, C500, C1000H, C2000H

### 3-2 Communications Protocol

The host computer has initial transmission priority. Data transfer between the host computer and the Host Link System is, therefore, initiated when the computer sends a command to a PC in the Host Link System.

A set of data in a transmission is called a block. The data block sent from the host computer to the Host Link System is called a command block. The block sent from the Host Link System to the computer is called a response block. In a multiple-link communications system, each block starts with a unit number and a header, and ends with a Frame Checksum (FCS) code and a terminator ( and CR). In a single-link system, however, each block starts with only a header, and ends with only a terminator. The terminator in the command block enables the PC to send a response. The terminator in the response block enables the host computer to send another command. Examples of communications are included at the end of *Section 4 Commands and Responses*.

#### 3-2-1 Block Format

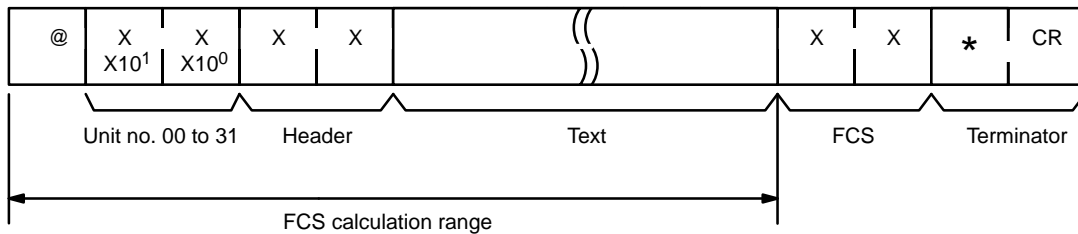

A block is usually made up of one unit called a frame, but long blocks of data (over 131 characters) must be divided into more than one frame before transmission. In a multiple-link system, the first frame can have up to 131 characters, and subsequent frames can have up to 128 characters. In a single-link system, however, every frame (the first included) has up to 128 characters. The data must then be divided into more than one frame when there is a block consisting of more than 131 characters in a multiple-link system, and of more than 128 characters in a single-link system. In this case, the beginning and intermediate blocks end with a delimiter (CR), instead of a terminator ( and CR).

### 3-2-2 Block Format With More Than One Frame

#### Multiple-link System

##### First Frame (131 Characters or Less)

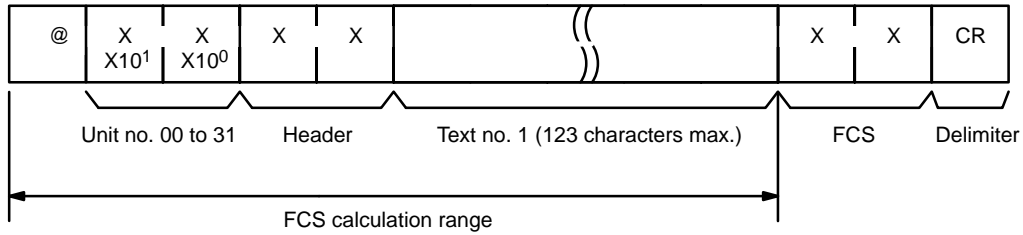

##### Intermediate Frame(s) (128 Characters or Less)

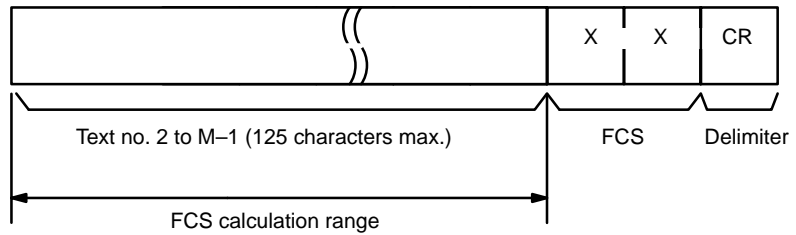

##### Last Frame (128 Characters or Less)

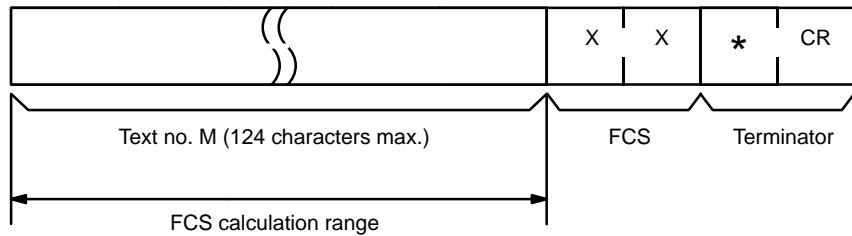

#### Single-link System

##### First Frame (128 Characters or Less)

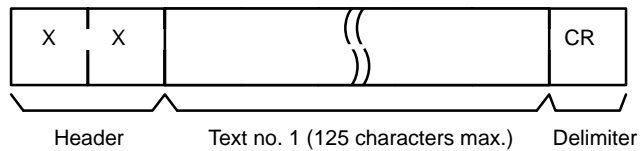

##### Intermediate Frame(s) (128 Characters or Less)

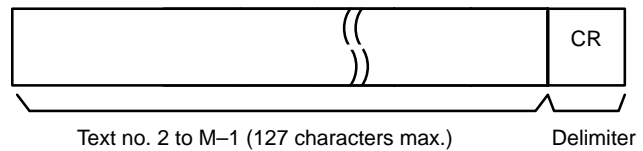

##### Last Frame (128 Characters or Less)

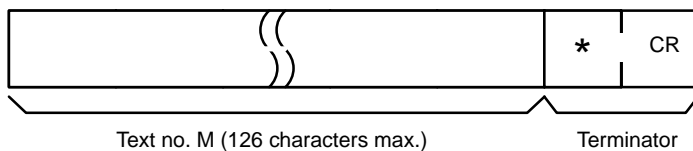

**Sending Commands**

To send a command block with more than one frame from the computer, initially send only the first frame in the block. Do not send the next frame until the host computer has received the delimiter which should have been sent back from the PC. Do not separate data from a single word into different frames for any write command.

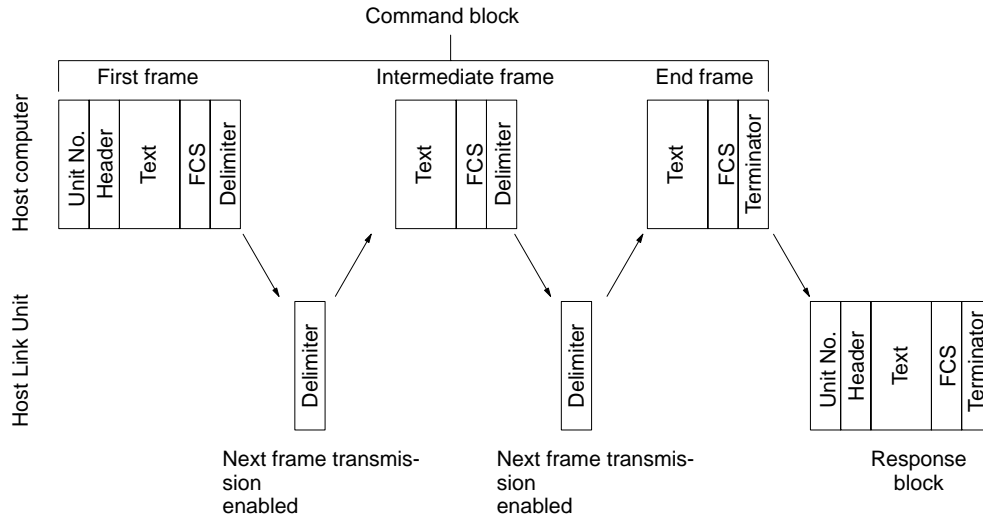

**Receiving Commands**

To receive a response block consisting of more than one frame from the PC, the host computer must send the carriage return code (delimiter) to the PC after receiving the delimiter from the PC. This enables the PC to send the next frame.

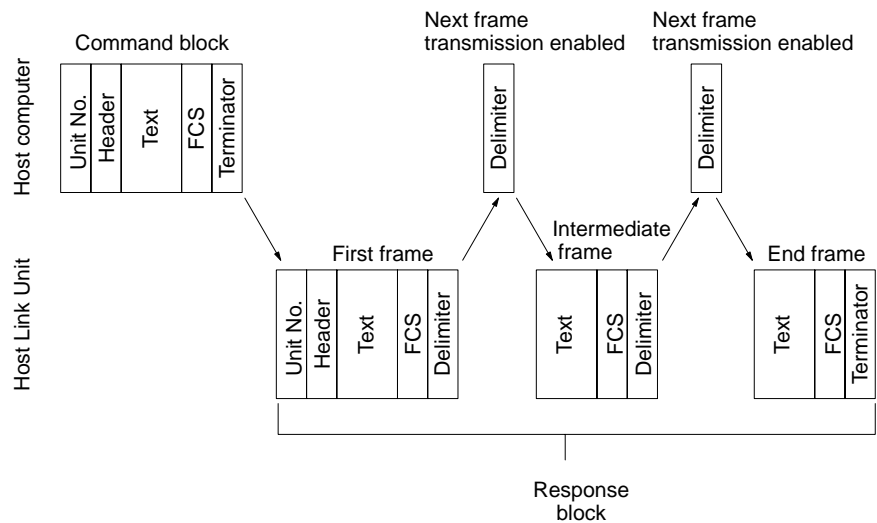

**3-2-3 Data Representation**

The format examples in this manual apply to multiple-link systems. The explanation for each command/response includes the ranges of the possible data (e.g., program instructions to be read, operand values, etc.). The actual data that is valid for the system depends on the PCs being used. Therefore, it is important that you check that the program instructions and the data areas (and sizes) are available for the PCs in your system.

Numerical data within a transmission is expressed in hexadecimal, decimal, or binary format. Refer to the format example of each command for details. The appropriate range is indicated in the following manner. Conversion tables in *Appendix C* give data conversions from ASCII to hex, binary, and decimal, and those in *Appendix D* give conversions between hex, BCD, binary, and decimal up to the value 32<sub>dec</sub>.

**Note** All ASCII data is stored as hex in the PCs.

**Hexadecimal Data**

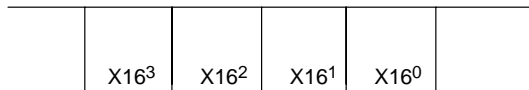

In the above diagram, the elements X16<sup>3</sup> to X16<sup>0</sup> indicate that the data is expressed in hexadecimal. Each digit can, therefore, be in the range from 0 (ASCII 48<sub>dec</sub>, binary 0000) to 9 (ASCII 49<sub>dec</sub>, binary 1001), or A (ASCII 65<sub>dec</sub>, binary 1010) to F (ASCII 70<sub>dec</sub>, binary 1111).

**Decimal Data**

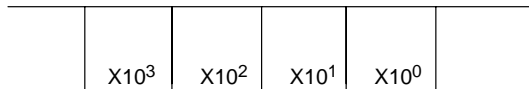

In this figure, X10<sup>3</sup> to X10<sup>0</sup> indicate that the data is expressed in decimal. Each digit can, therefore, be in the range from 0 (binary 0000) to 9 (binary 1001).

**Binary Data**

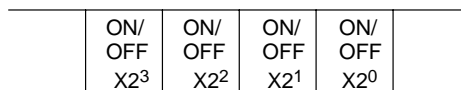

In the above figure, the ON/OFF and X2<sup>3</sup> to X2<sup>0</sup> indicate that the data is binary. Each box therefore represents either 0 or 1 as follows:

- 0 (ASCII 48<sub>dec</sub>): OFF
- 1 (ASCII 49<sub>dec</sub>): ON.

**Data Areas**

Data area codes must be entered in capital letters and must be 4 characters wide. Names shorter than 4 characters must be followed by spaces (ASCII 32<sub>dec</sub>) to make up the 4 characters. Data areas valid for each command are listed with the command.

A maximum of 29 words of PC data can be sent at the same time. If a command is used to read or write more than 29 words, the transmission will be divided into units of 29 words or less each.

Although the C200H/HS/HX/HG/HE, C1000H, and C2000H will complete processing a read or write command in one cycle, other PCs may require up to three cycles to complete processing for all the data being transferred.

If separate commands are used to read data from a PC, the data may not all result from the same PC program cycle.

### 3-2-4 System Checks

Prior to an actual data transaction between the Host Link Unit and host computer, check the system by following the nine steps listed below.

- 1, 2, 3... 1. Check the settings of the Host Link Unit's DIP switches and selectors. make sure the transmission speeds, specified interfaces, and data formats of both the Host Link Unit and host computer match.
2. Mount the Host Link Unit to the PC.
3. Connect the Host Link Unit to the host computer with the proper cable. For details, refer to *Sections 1 Introduction and 2 Host Link Unit Characteristics*.
4. Apply power to the PC and the host computer.
5. If the ERROR or ALARM indicators on the PC illuminate, rectify the error and then clear the alarm.
6. If the Host Link Unit is ready, the RUN indicator will illuminate. Confirm that this is ready before proceeding.
7. Prepare and execute a test program on the host computer.
8. If the data test is completed successfully, the system is operational.
9. If an error occurs, perform the required error processing as detailed in *Section 5 Error Processing*.

### 3-2-5 Data Transaction Test Program

The following program example is designed to send test data to the Host Link Unit and return it, unaltered, to the host computer. By executing this program, the transmit and receive data are both displayed on the screen of the host computer. If the transmit data and the receive data match, the system is operational. The example uses a multiple-link system, and the program is executed by Host Link Unit number 0. The following program is for NEC computers. For IBM compatibles, four lines must be changed as shown after the program.

**NEC**

```

10 CLOSE #1
20 CLS
30 ON ERROR GOTO *EROPE
40 OPEN "COM:E73" FOR OUTPUT AS #1 ..... Opens RS-232C
50 ' *****
60 *KEYIN
70 INPUT "TEST DATA INPUT -----", TDS ..... Test data input
80 ICS="@OUTS" ..... Creation of Unit no. and header code
90 TS=TCS+TDS ..... Creation of test command
100 GOSUB *FCSSET ..... Calculation of Frame Checksum
110 TXDS=TS+FCSS+"*" ..... Send data set
120 PRINT TXDS ..... Send data display
130 PRINT #1, TXDS ..... Transmission
140 INPUT #1, RXDS ..... Reception
150 LINE PRINT RXDS ..... Receive data display
160 GOTO *KEYIN
170 ' *****
180 *FCSSET ..... *
190 L=LEN(TS) ..... Number of transmit data before FCS
200 A=0 ..... Setting of initial value for EOR calculation
210 FOR J=I TO L
220 TJS=MIDS(TS, J, 1)
230 A=ASC(TJS) XOR A
240 NEXT J
250 FCSS=HEXS(A)

```

```

260 IF LEN(FCSS)=1 THEN FCSS="0"+FCSS
270 RETURN
280 '*****
290 *EROPE
300 PRINT "ERL=";ERL,"ERR=";ERR . . . . . Display of line no. containing error and error no.
310 CLOSE #1
320 END . . . . . Closes RS-232C
330 '*****
    
```

\* The FCS calculation subroutine starting from statement 180 is for data transmission. The data length L will differ for the response because the response contains other data such as FCS and \*.

**IBM** To adjust the above program for IBM compatibles replace the following four lines.

```

30 ON ERROR GOTO 300
40 OPEN "COM:E72" FOR OUTPUT AS#1

100 GOSUB 190

160 GOTO 70
    
```

### 3-3 Communications Protocol (C200HS/HX/HG/HE only)

**Commands from the PC** The C200HS/HX/HG/HE allows the PC to issue commands to the host computer under the following conditions. The command makes it possible to send the PC's data to the host computer without using any command from the host computer.

- 1, 2, 3... 1. The C200HS/HX/HG/HE must be connected to the host computer via a C200H-LK101-PV1, C200H-LK2□□-V1 Host Link Unit or the peripheral port of the C200HS/HX/HG/HE's CPU. Refer to the *C200HS Operation Manual* or *C200HX/HG/HE Operation Manual* for details.
2. The TRANSMIT (TXD (—)) must be executed from the user ladder-diagram program. Refer to 4-36 *TRANSMIT* for details.

When the TXD (—) instruction is executed, data is transmitted to the host computer in the following format.

**Command Format**

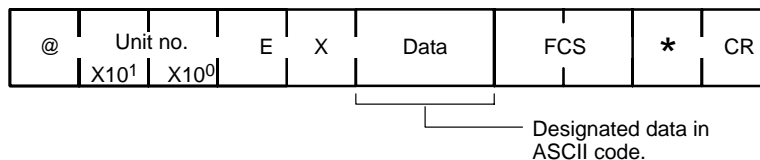

The data (61 bits maximum) specified by the TXD (—) instruction is converted into ASCII (122 characters maximum) and transmitted. There will be no response from the host computer for the above command.

### 3-3-1 Command Timing

When the Host Link Unit is receiving a command from the host computer at the time the execution of the TRANSMIT instruction has been completed, command transmission to the host computer is possible only after the Host Link Unit completes receiving the command from the host computer. After receiving the command from the host computer, the Host Link Unit starts command transmission to the host computer. The transmission of a response for the command from the host computer is possible only after the command transmission to the host computer is completed.

#### PC Data Transmission

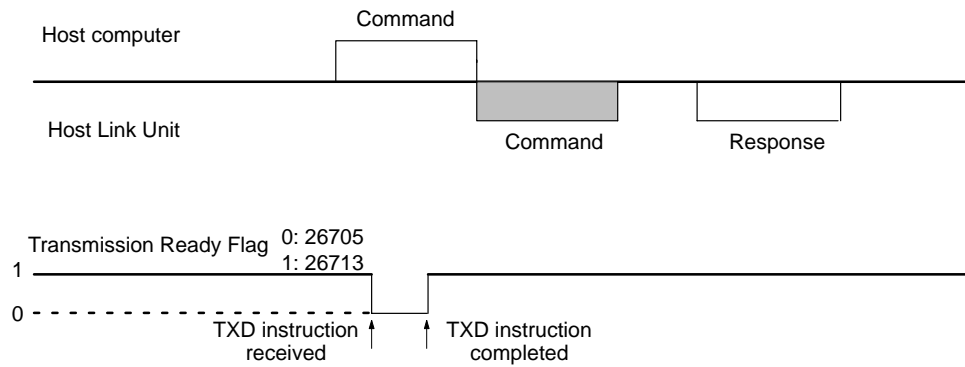

When the Host Link Unit is transmitting a response for a command transmitted from the host computer at the time the execution of the TRANSMIT instruction has been completed, command transmission to the host computer is possible only after the Host Link Unit completes transmitting the response to the host computer. After transmitting the response, the Host Link Unit starts command transmission to the host computer.

#### PC Data Reception

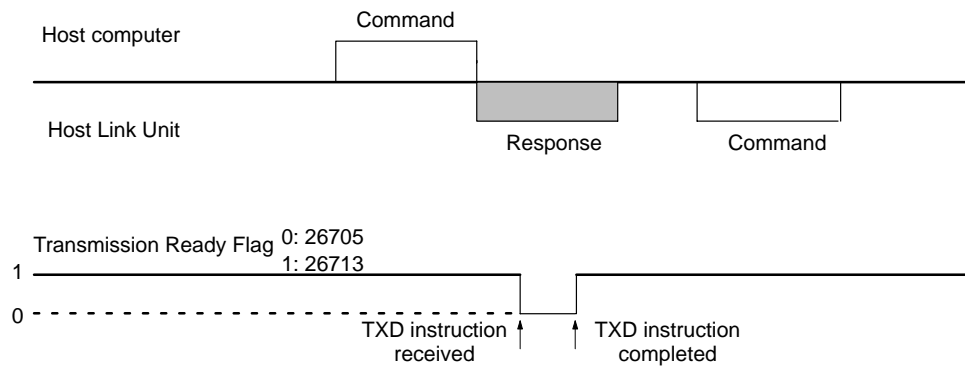

The transmission flag is ON when a command to the host computer is delivered from the PC to the Host Link Unit.

### 3-4 Frame Checksum (FCS) Calculation

The Frame Checksum is 8-bit data converted into two ASCII characters. The 8-bit data is the result of an EXCLUSIVE OR sequentially performed between each character, from the first character in the frame to the last character of the text in that frame.

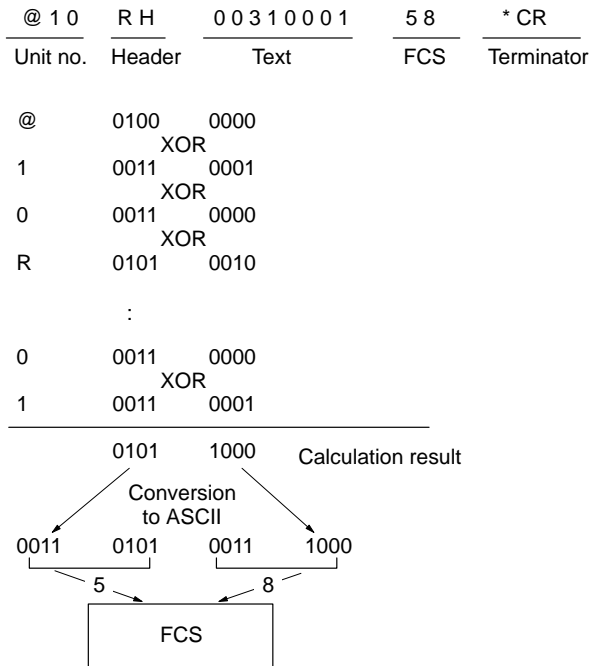

#### 3-4-1 FCS Calculation Program Example

The following program is an example of how Frame Checksum calculations can be performed on received data. For an example of a program to calculate the FCS for Transmit Data, refer to 3-2-4 System Checks.

```

400 *FCSCHECK
405 L=LEN (RESPONSE$) ----- Transmit/receive data
410 Q=0:FCSCK$=" "
415 A$=RIGHT$ (RESPONSE$, 1)
417 PRINT RESPONSE$, A$, L
420 IF A$="*" THEN LENG$=LEN (RESPONSE$)-3 ELSE LENG$=LEN (RESPONSE$)-2
430 FCSP$=MID$ (RESPONSE$, LENG$+1, 2)
440 FOR I=1 TO LENG$ ----- Number of characters in FCS calculation range.
450 Q=ASC (MID$ (RESPONSE$, I, 1)) XOR Q ----- Receive data contains an FCS, delimiter,
460 NEXT I ----- terminator, etc. The ABORT command,
470 FCSD$=HEX$ (Q) ----- however, does not contain an FCS.
480 IF LEN (FCSD$)=1 THEN FCSD$="0"+FCSD$ ----- FCS calculation result
490 IF FCSD$ <> FCSP$ THEN FCSCK$="ERR" ----- Receive FCS data
495 PRINT "FCSD$="; FCSD$, "FCSP$="; FCSP$, "FCSCK$="; -- A space follows the semicolon if the
500 RETURN ----- FCS reception is performed normally. If
----- it is not performed, ERR is displayed.

```

Note: in this example, CR (CHR\$(13)) is not included in RESPONSE\$.

# SECTION 4

## Commands and Responses

This section provides the command and response formats for all of the instructions covered by this manual. A table of the responses produced for different errors is included in *4-45 Response Code List*. Examples of communications between a Host Link Unit and PC, for several commands, are given at the end of the *4-46 Communications Examples*. The levels at which the commands are applicable are given in table form in *3-1 Command Levels*.

4-1	TEST	.....
4-2	STATUS READ	.....
4-3	ERROR READ	.....
4-4	IR AREA READ	.....
4-5	HR AREA READ	.....
4-6	AR AREA READ	.....
4-7	LR AREA READ	.....
4-8	TC STATUS READ	.....
4-9	DM AREA READ	.....
4-10	FM INDEX READ	.....
4-11	FM DATA READ	.....
4-12	PV READ	.....
4-13	SV READ 1	.....
4-14	SV READ 2	.....
4-15	SV READ 3	.....
4-16	STATUS WRITE	.....
4-17	IR AREA WRITE	.....
4-18	HR AREA WRITE	.....
4-19	AR AREA WRITE	.....
4-20	LR AREA WRITE	.....
4-21	TC STATUS WRITE	.....
4-22	DM AREA WRITE	.....
4-23	FM AREA WRITE	.....
4-24	PV WRITE	.....
4-25	SV CHANGE 1	.....
4-26	SV CHANGE 2	.....
4-27	SV CHANGE 3	.....
4-28	FORCED SET	.....
4-29	FORCED RESET	.....
4-30	MULTIPLE FORCED SET/RESET	.....
4-31	MULTIPLE FORCED SET/RESET STATUS READ	.....
4-32	FORCED SET/RESET CANCEL	.....
4-33	PC MODEL READ	.....
4-34	DM HIGH-SPEED READ	.....
4-35	ABORT and INITIALIZE	.....
4-36	TRANSMIT (C200HS/HX/HG/HE only)	.....
4-37	Response to an Undefined Command	.....
4-38	Response Indicating an Unprocessed Command	.....
4-39	PROGRAM READ	.....
4-40	I/O TABLE READ	.....
4-41	PROGRAM WRITE	.....
4-42	I/O TABLE GENERATE	.....
4-43	I/O REGISTER	.....
4-44	I/O READ	.....
4-45	Response Code List	.....
4-46	Communications Examples	.....

### 4-1 TEST

Transmits one block of data to the PC and then returns it, unaltered, to the host computer. Each frame is treated as a block regardless of whether it uses a terminator or delimiter.

#### Command Format

@	Unit no. X10 <sup>1</sup> X10 <sup>0</sup>	T	S	Any characters (122 max.) other than a carriage return	FCS	*	CR
---	---	---	---	--	-----	---	----

#### Response Format

@	Unit no. X10 <sup>1</sup> X10 <sup>0</sup>	T	S	Any characters (122 max.) other than a carriage return	FCS	*	CR
---	---	---	---	--	-----	---	----

#### Response if Error Occurs

@	Unit no. X10 <sup>1</sup> X10 <sup>0</sup>	T	S	Response code X16 <sup>1</sup> X16 <sup>0</sup>	*	CR
---	---	---	---	--	---	----

### 4-2 STATUS READ

Reads the operating status of the PC.

#### Command Format

@	Unit no. X10 <sup>1</sup> X10 <sup>0</sup>	M	S	FCS	*	CR
---	---	---	---	-----	---	----

#### Response Format

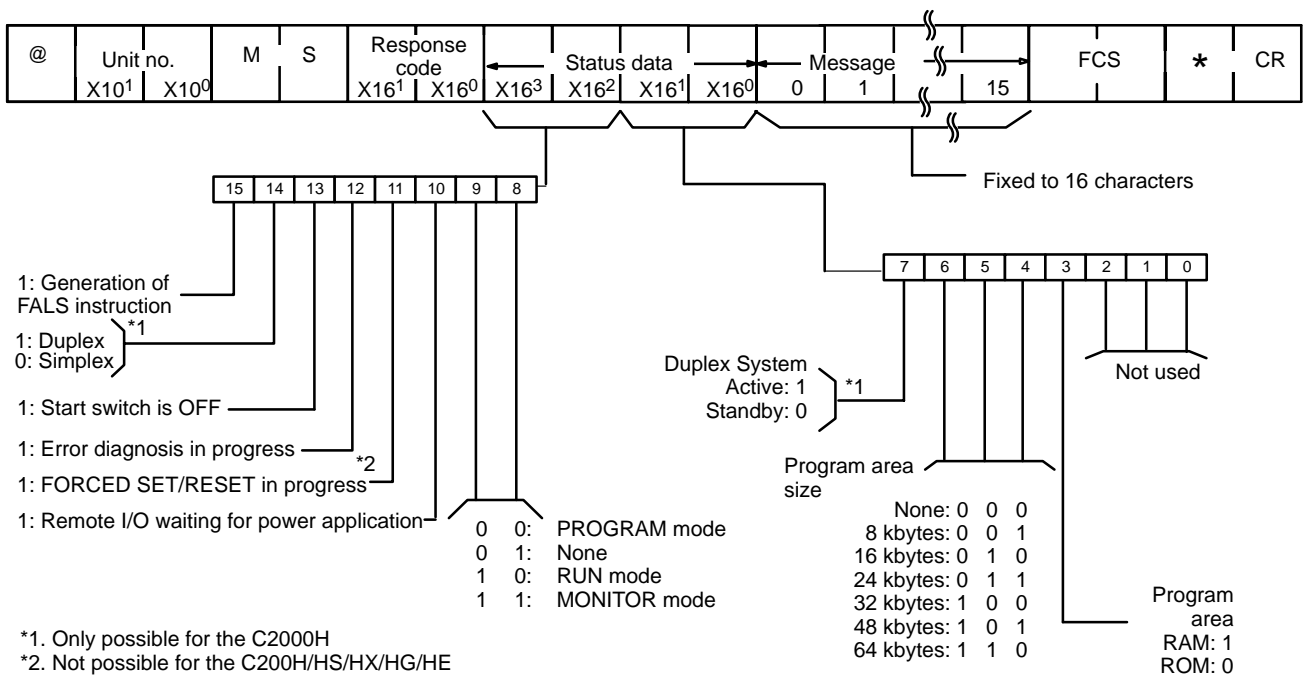

### 4-3 ERROR READ

Reads and clears errors in the PC. Also checks whether previous errors have already been cleared. When both Rack- and CPU-mounting Host Link Units are used in combination, errors in either type of Unit are indicated in the same manner.

#### Command Format

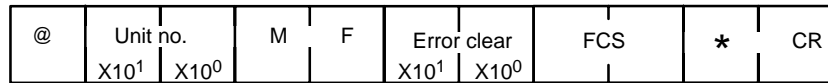

00: Error is not cleared  
01: Error is cleared

#### Response Format

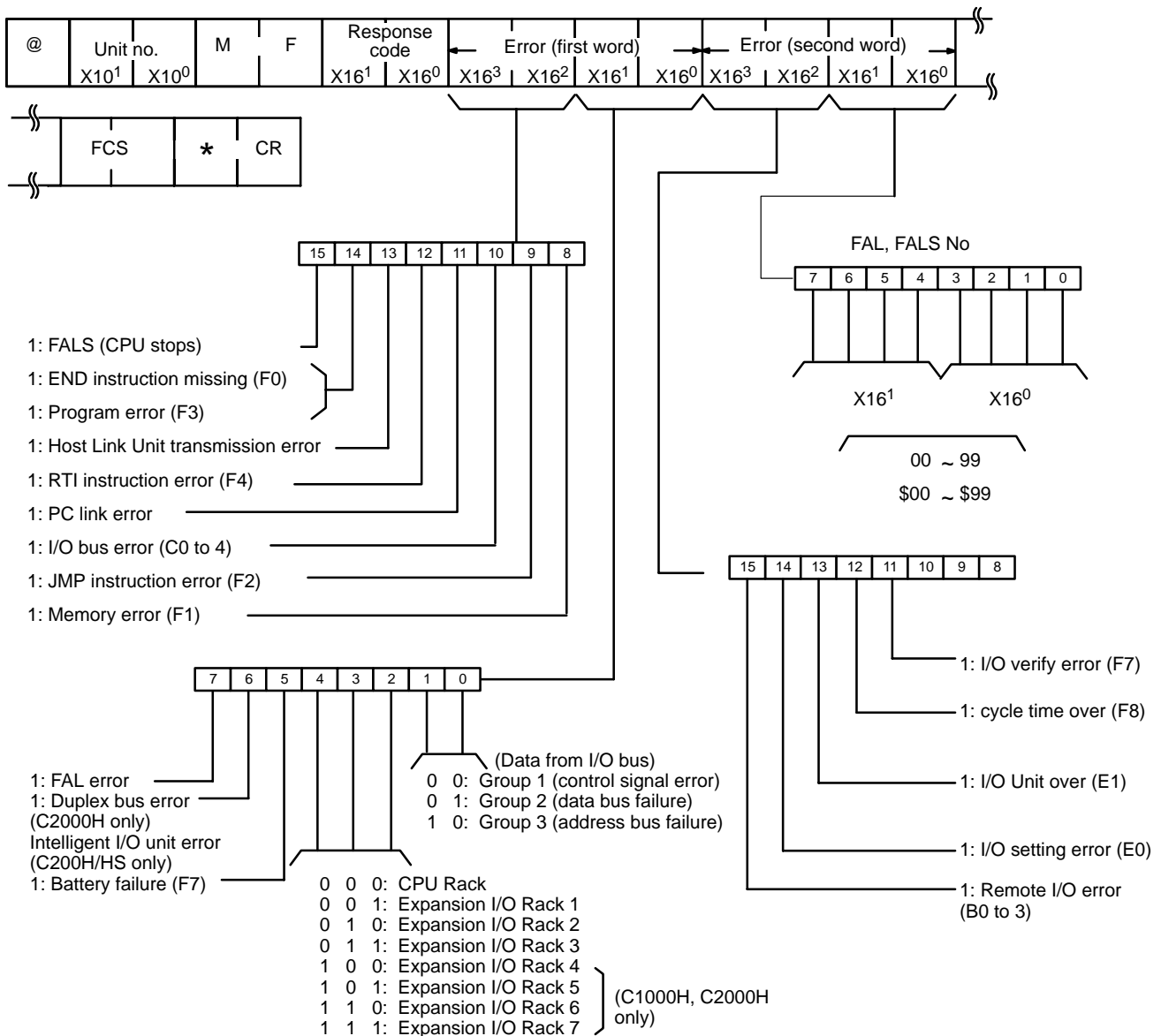

### 4-4 IR AREA READ

Reads the contents of the specified number of IR area words, starting from the specified word.

**Command Format**

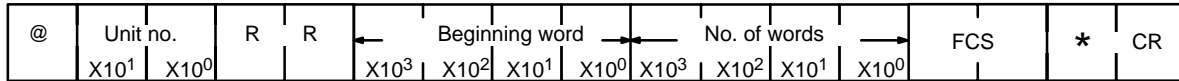

**Response Format**

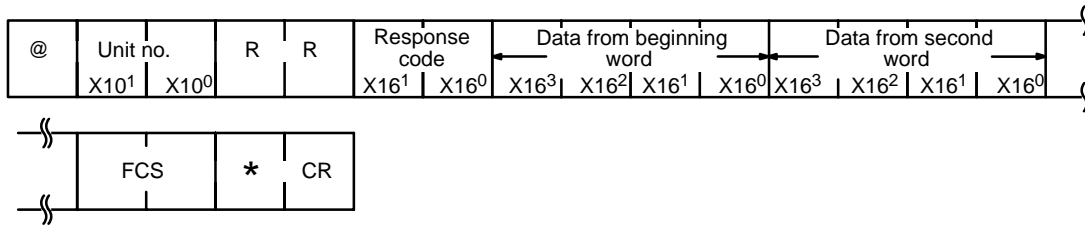

### 4-5 HR AREA READ

Reads the contents of the specified number of HR area words, starting from the specified word.

**Command Format**

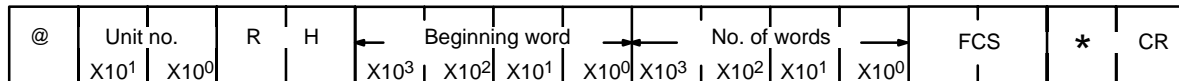

**Response Format**

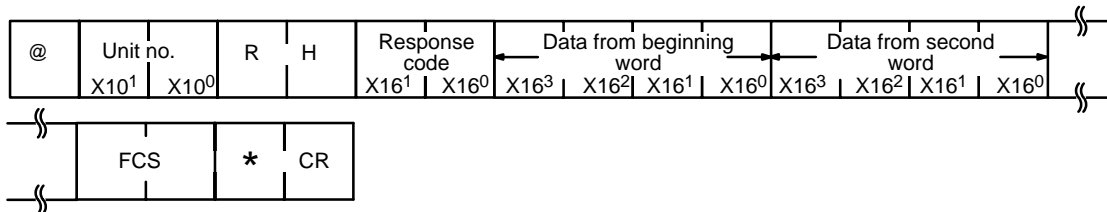

### 4-6 AR AREA READ

Reads the contents of the specified number of AR area words, starting from the specified word.

**Command Format**

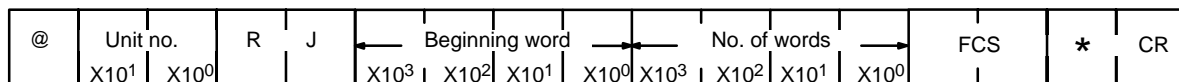

Response Format

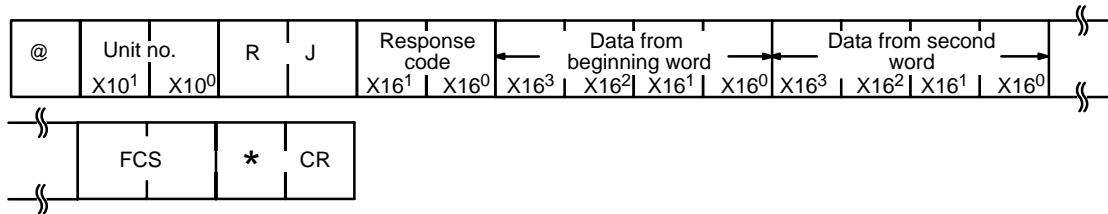

### 4-7 LR AREA READ

Reads the contents of the specified number of LR area words, starting from the specified word.

Command Format

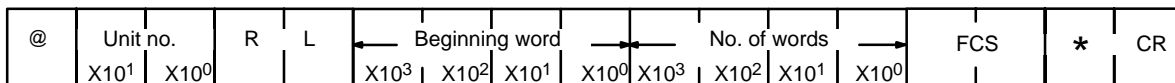

Response Format

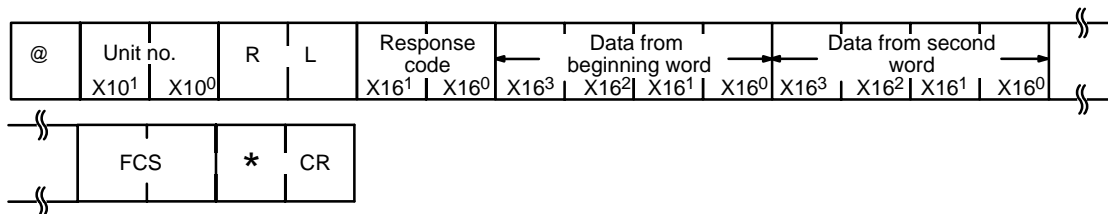

### 4-8 TC STATUS READ

Reads the status of the Completion Flags of the specified number of timers/counters, starting from the specified timer/counter.

Command Format

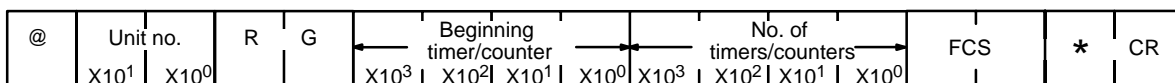

Response Format

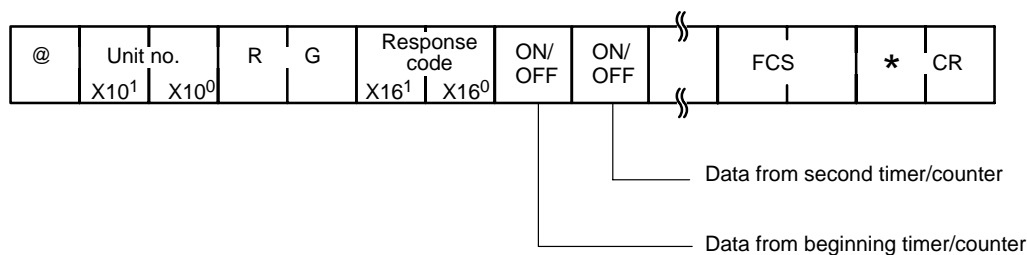

### 4-9 DM AREA READ

Reads the contents of the specified number of DM words, starting from the specified word.

**Command Format**

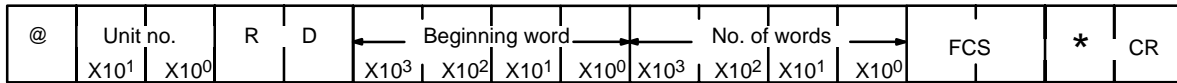

**Response Format**

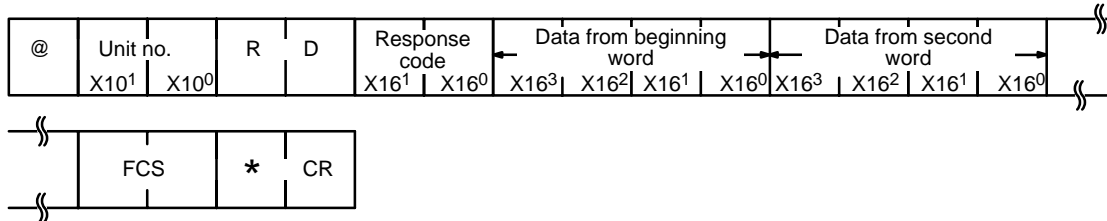

### 4-10 FM INDEX READ

Reads the contents of the specified number of FM index blocks, starting from the specified block.

**Command Format**

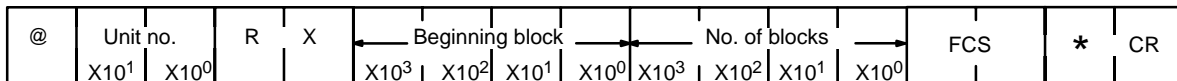

**Response Format**

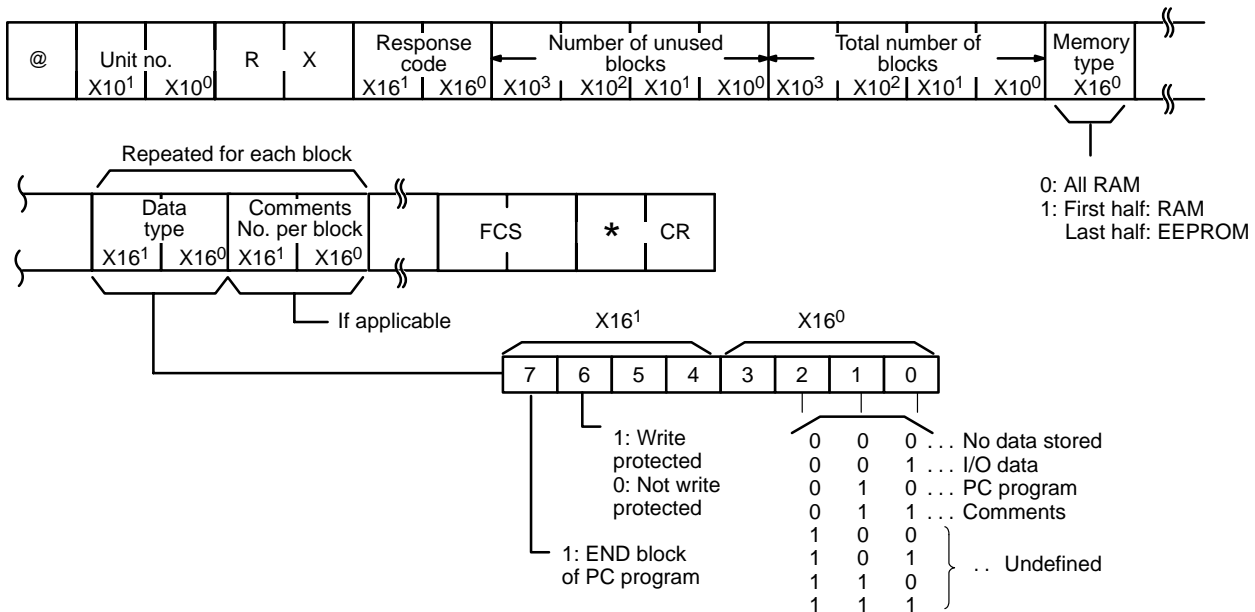

### 4-11 FM DATA READ

Reads the contents of the specified number of FM blocks, starting from the specified block. The “data type” and “comments per block” information can be added to each block, separated by a delineator, i.e., a comma (,).

#### Command Format

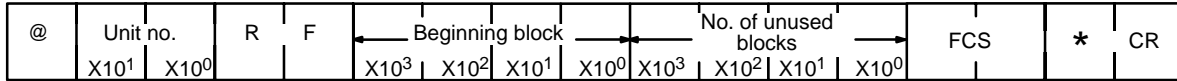

#### Response Format

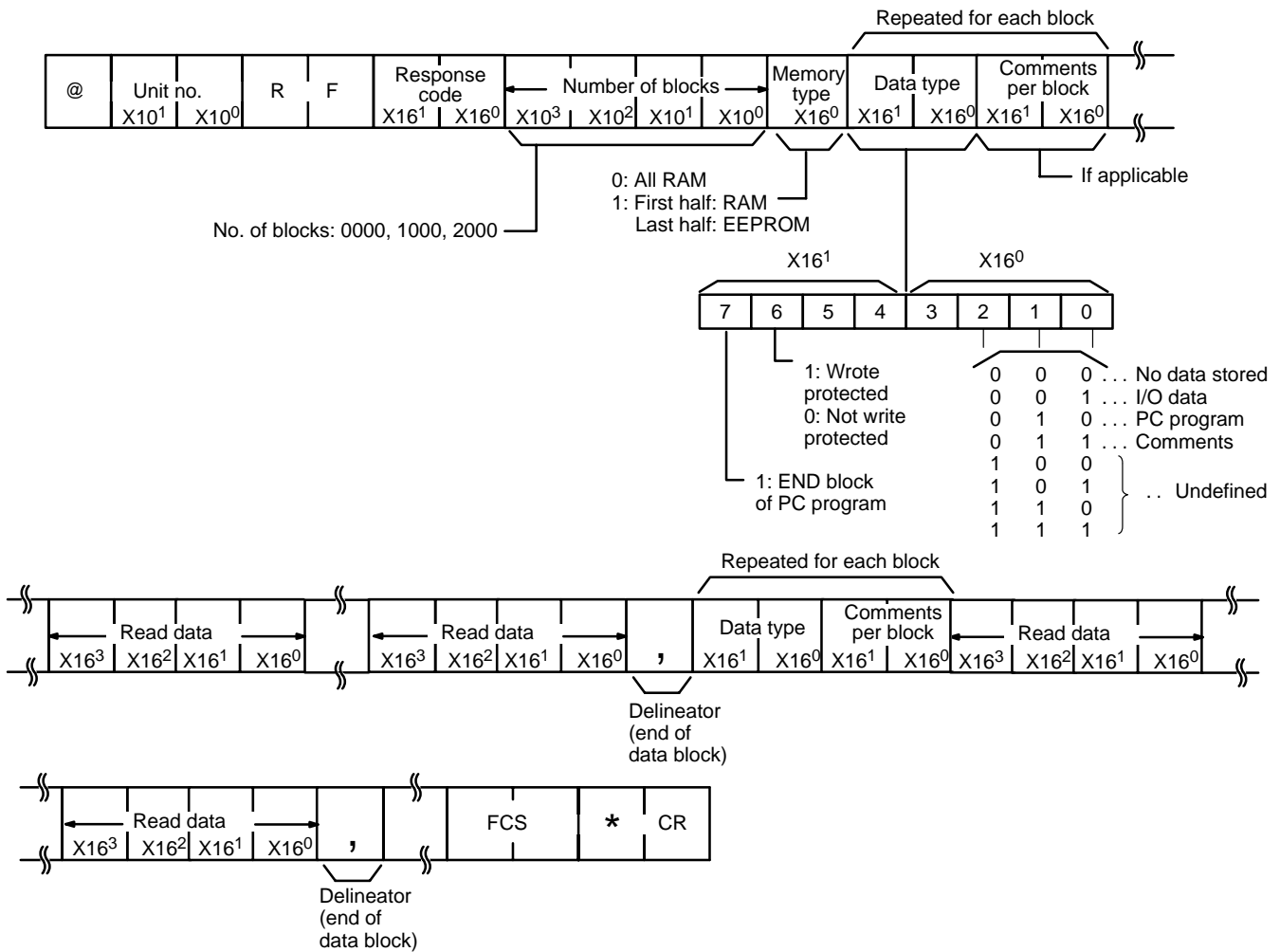

### 4-12 PV READ

Reads the specified number of timer/counter PVs (present values), starting from the specified timer/counter.

#### Command Format

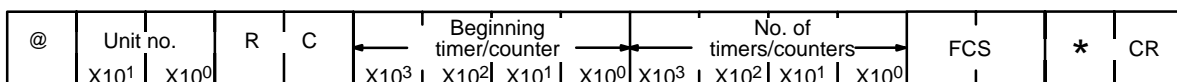

Response Format

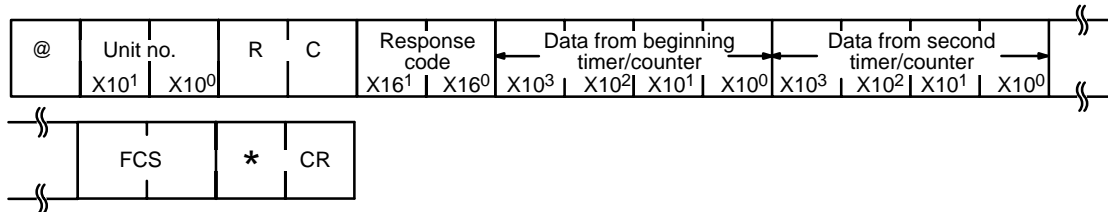

### 4-13 SV READ 1

Reads the set value (a constant) of the specified timer/counter instruction. Reads from the beginning of the program and can therefore take up to 20 seconds to produce a response. Refer also to 4-14 SV READ 2 and 4-15 SV READ 3.

Command Format

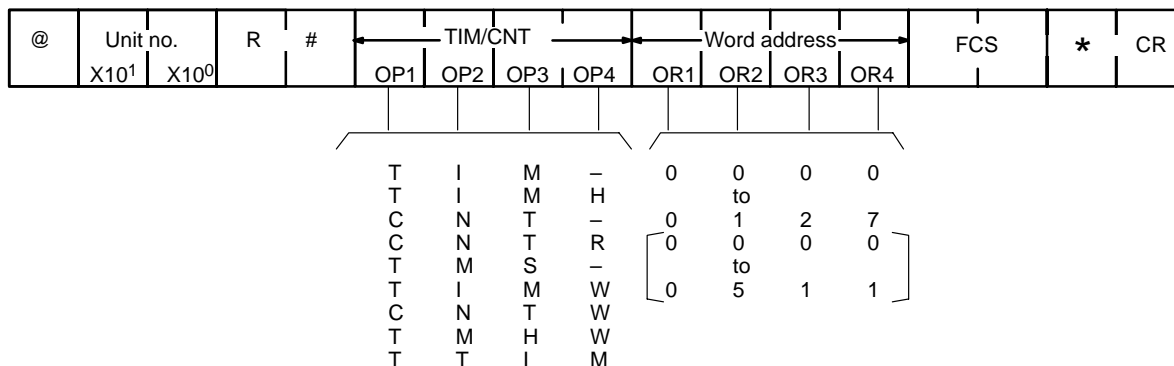

- Note**
1. Dashes represent spaces.
  2. The data in the brackets apply to the C200H, C200HS, C200HX, C200HG, C200HE, C1000H, and C2000H.

Response Format

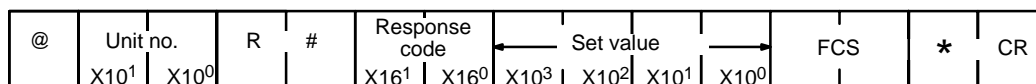

If the command is used more than once, the set value of only the first instruction will be read.

# 4-14 SV READ 2

Reads the set value (a constant, or data area and word) of the specified timer/counter instruction. The timer/counter instruction is designated by its program address. If the program has more than 9,999 addresses, use SV READ 3, described in the next section.

### Command Format

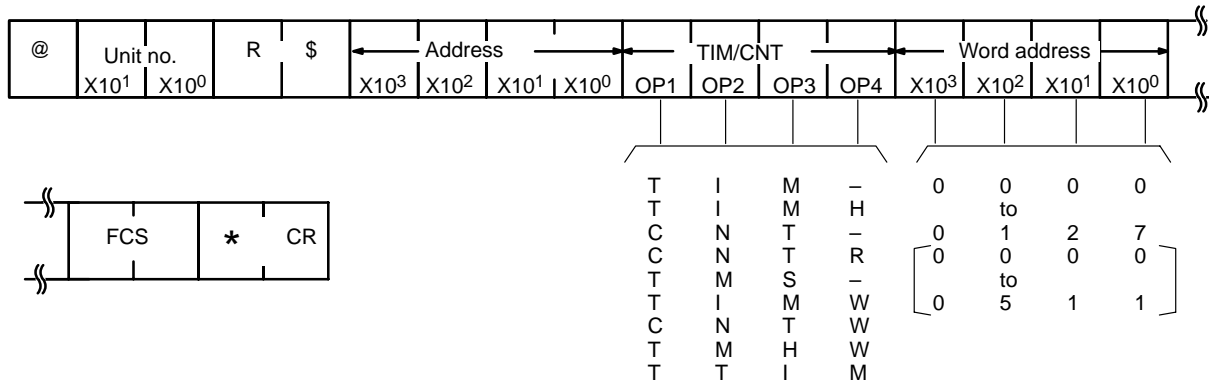

- Note**
1. Dashes represent spaces.
  2. The data in the brackets apply to the C200H, C200HS, C200HX, C200HG, C200HE, C1000H, and C2000H.

### Response Format

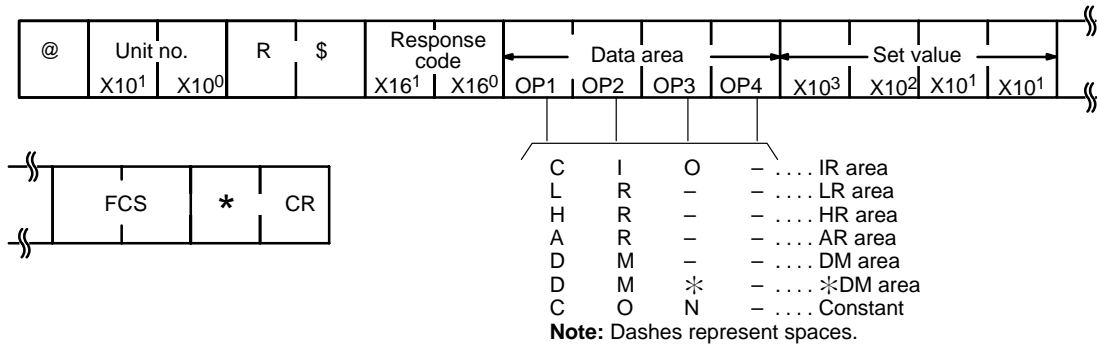

### 4-15 SV READ 3

Reads the set value (a constant, or data area and word) of the specified timer/counter instruction. The operation is similar to SV READ 2, but the SV READ 3 is capable of reading from higher program addresses (up to 6 digits).

#### Command Format

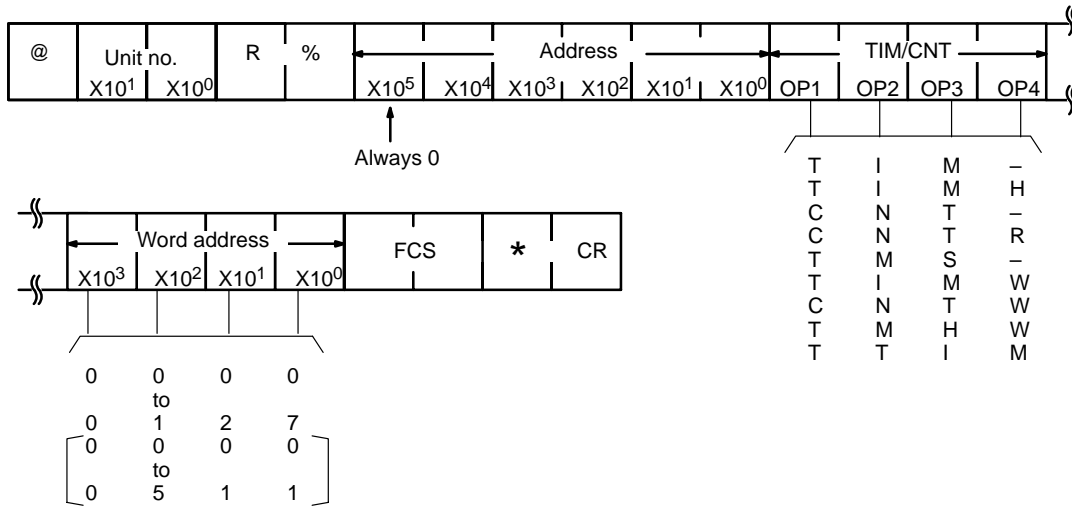

- Note**
1. Dashes represent spaces.
  2. The data in the brackets apply to the C200H, C200HS, C200HX, C200HG, C200HE, C1000H, and C2000H.

#### Response Format

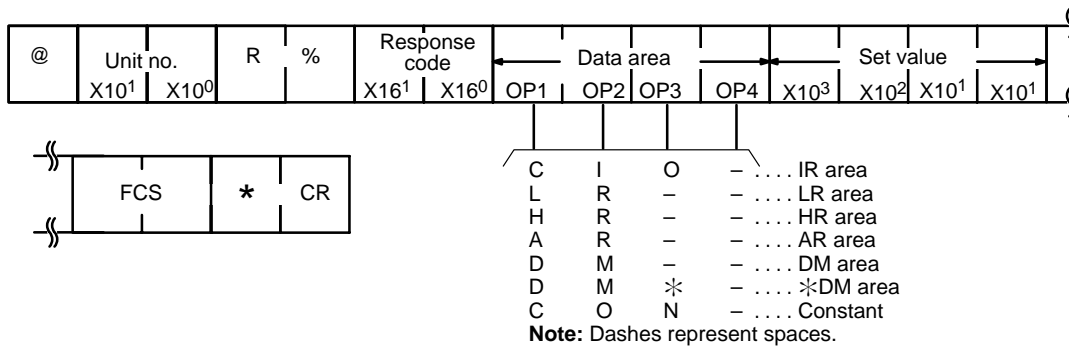

### 4-16 STATUS WRITE

Changes the operating mode of the PC according to the information entered into word X16<sup>0</sup>.

**Command Format**

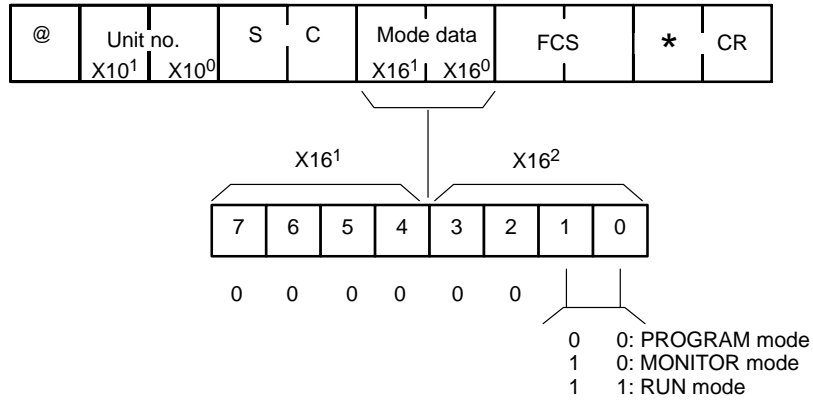

**Response Format**

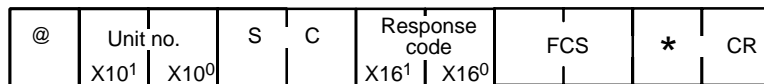

### 4-17 IR AREA WRITE

Writes data to the IR area, starting from the specified word. Writing is done word by word.

**Command Format**

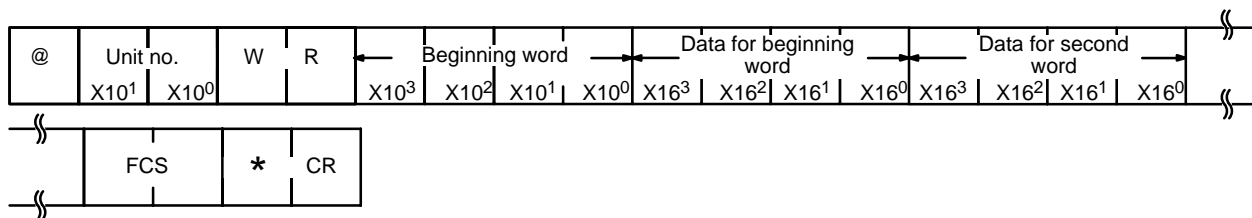

**Response Format**

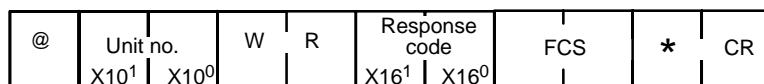

### 4-18 HR AREA WRITE

Writes data to the HR area, starting from the specified word. Writing is done word by word.

**Command Format**

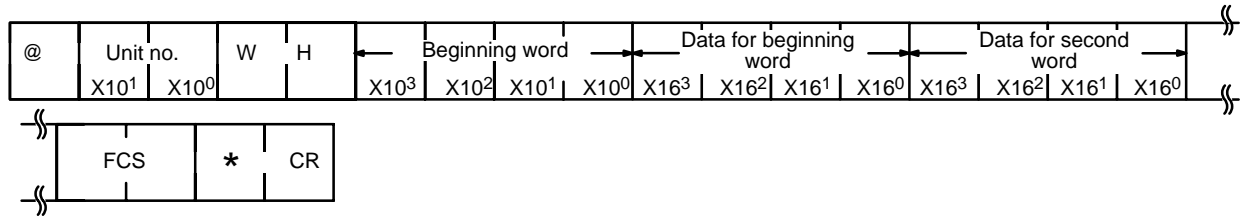

**Response Format**

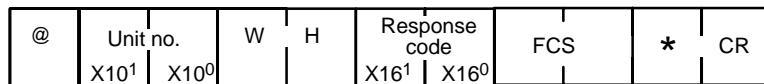

### 4-19 AR AREA WRITE

Writes data to the AR area, starting from the specified word. Writing is done word by word.

**Command Format**

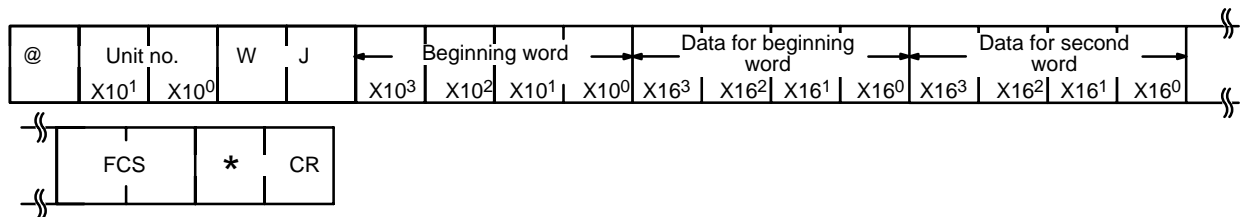

**Response Format**

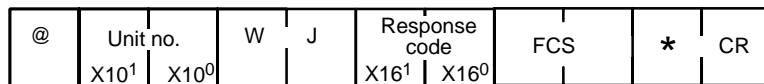

### 4-20 LR AREA WRITE

Writes data to the LR area, starting from the specified word. Writing is done word by word.

**Command Format**

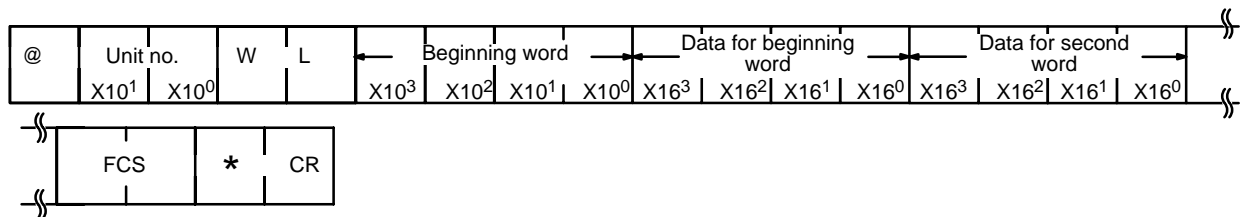

Response Format

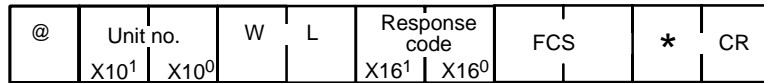

### 4-21 TC STATUS WRITE

Writes the status of the Completion Flags to the TC area, starting from the specified timer/counter.

Command Format

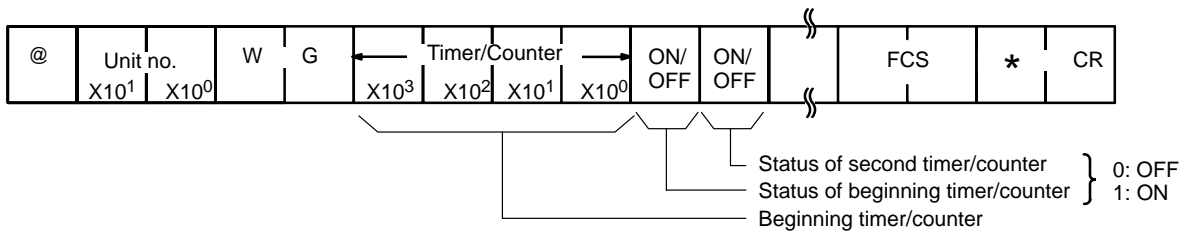

Response Format

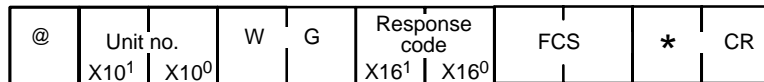

### 4-22 DM AREA WRITE

Writes data to the DM area, starting from the specified word. Writing is done word by word. If the Program Memory is in an EPROM chip, or if the write enable switch is set to OFF, the the writing range extends up to DM 0999 only.

Command Format

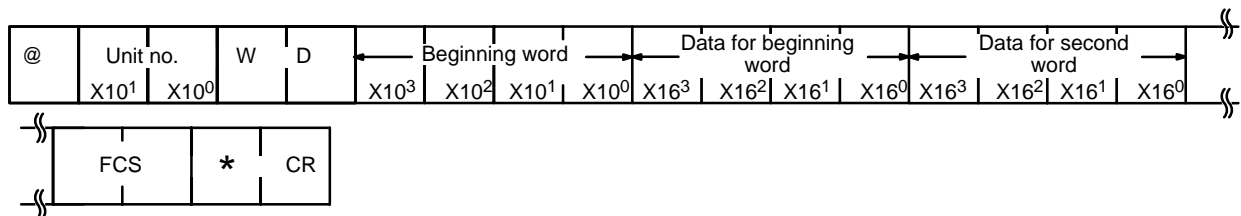

Response Format

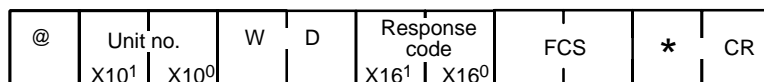

### 4-23 FM AREA WRITE

Writes data to a single specified word, or to an entire file memory block.

**Command Format**

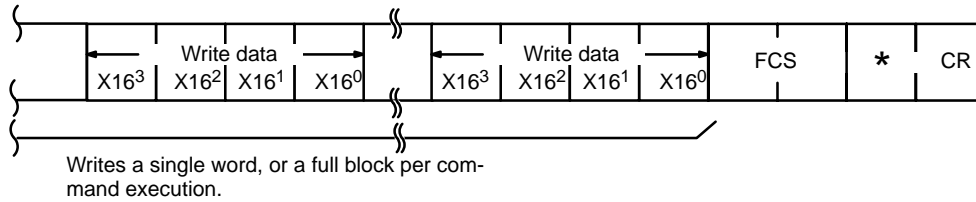
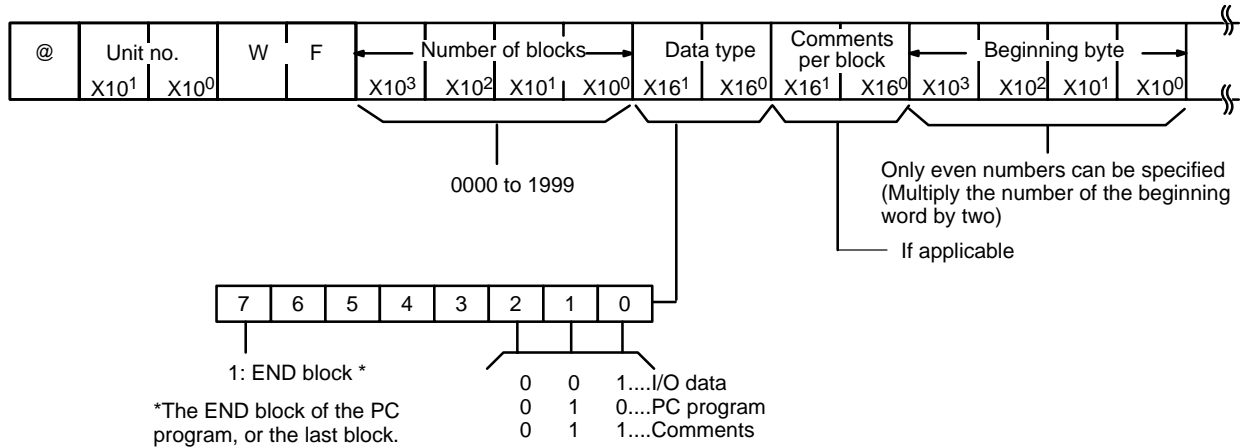

**Response Format**

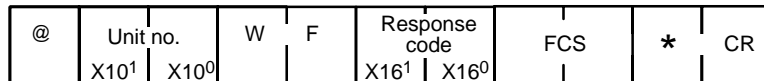

### 4-24 PV WRITE

Writes PVs (present values) of timers/counters, starting from the specified timer/counter.

**Command Format**

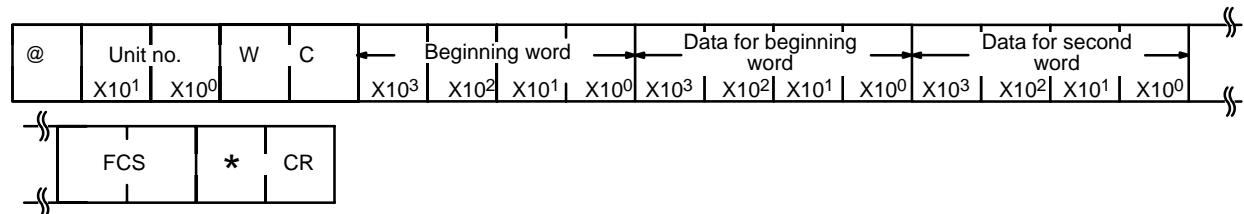

**Response Format**

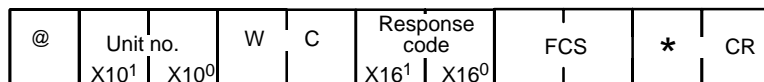

# 4-25 SV CHANGE 1

Changes the set value (constant only) of the specified timer/counter instruction. Reads from the beginning of the program and therefore take up to 20 seconds to produce a response. Refer also to 4-26 SV CHANGE 2 and 4-27 SV CHANGE 3.

### Command Format

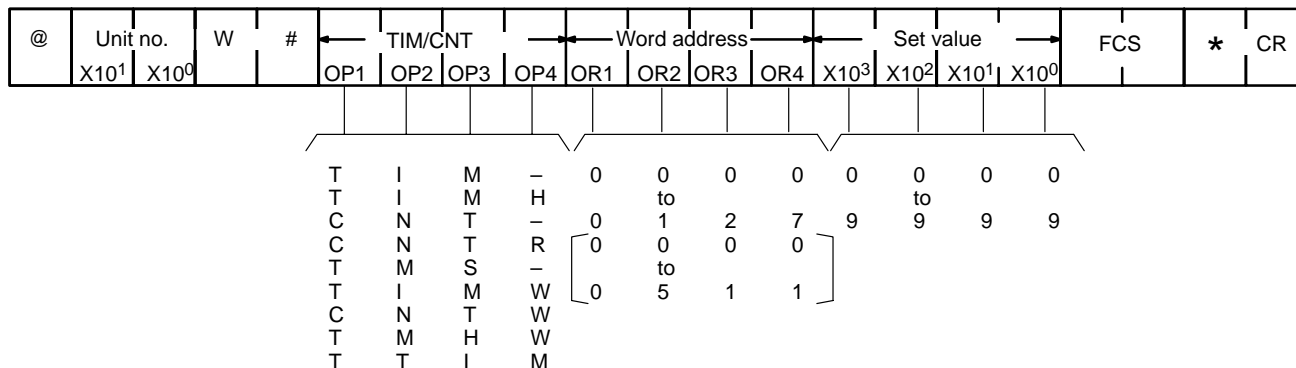

- Note**
1. Dashes represent spaces.
  2. The data in the brackets apply to the C200H, C200HS, C200HX, C200HG, C200HE, C1000H, and C2000H.

### Response Format

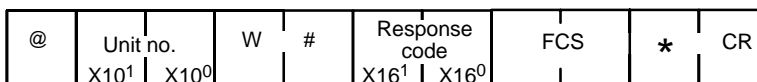



### 4-27 SV CHANGE 3

Changes the set value (a constant, or data area and word) of the specified instruction. The operation is similar to SV CHANGE 2, but SV CHANGE 3 can change SVs at higher program addresses (up to 5 digits, note that the leftmost, i.e., the sixth, address bit is always zero).

**Command Format**

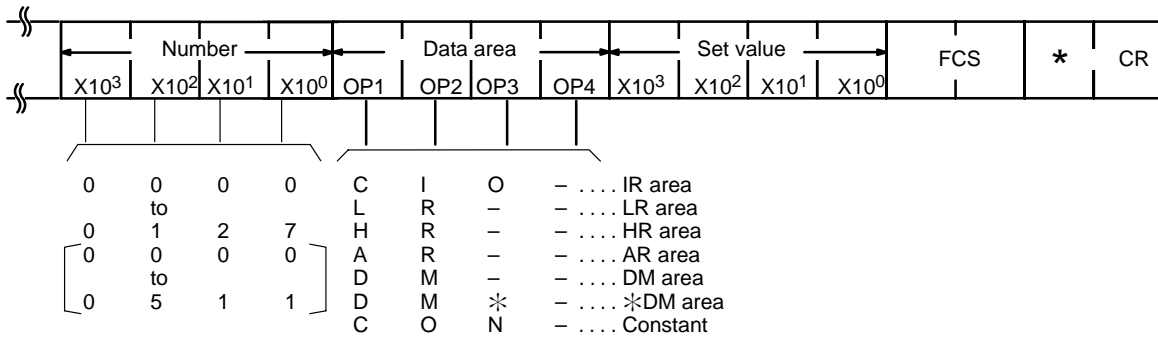
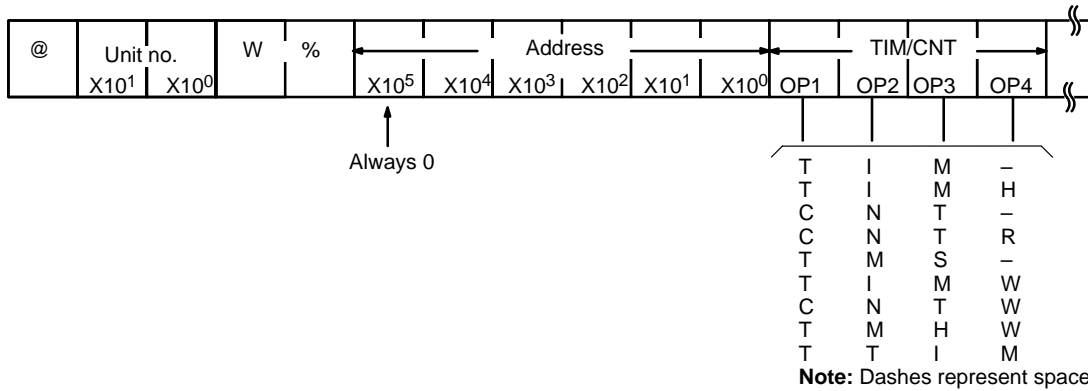

- Note**
1. Dashes represent spaces.
  2. The data in the brackets apply to the C200H, C200HS, C200HX, C200HG, C200HE, C1000H, and C2000H.

**Response Format**

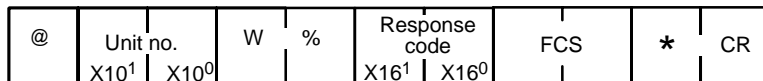

### 4-28 FORCED SET

Forced sets a bit in an IR, LR, HR, AR, or TC area. Bits need to be force set one at a time.

**Command Format**

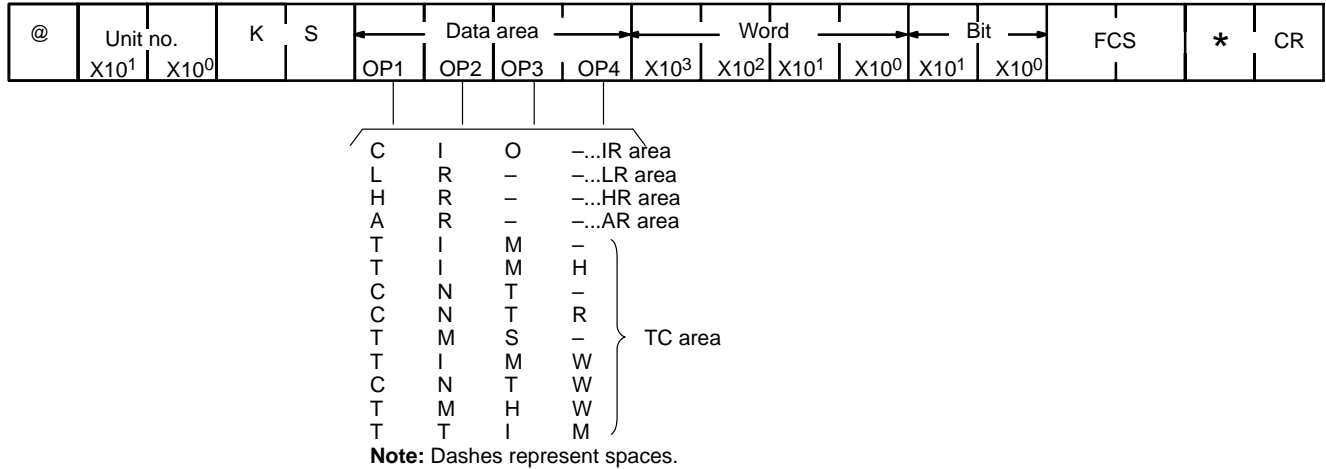

**Response Format**

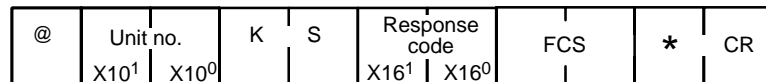

### 4-29 FORCED RESET

Force resets a bit in an IR, LR, HR, AR, or TC area. Bits can only be force reset one at a time. If an attempt is made to simultaneously force reset more than one bit, none of the bits will reset.

**Command Format**

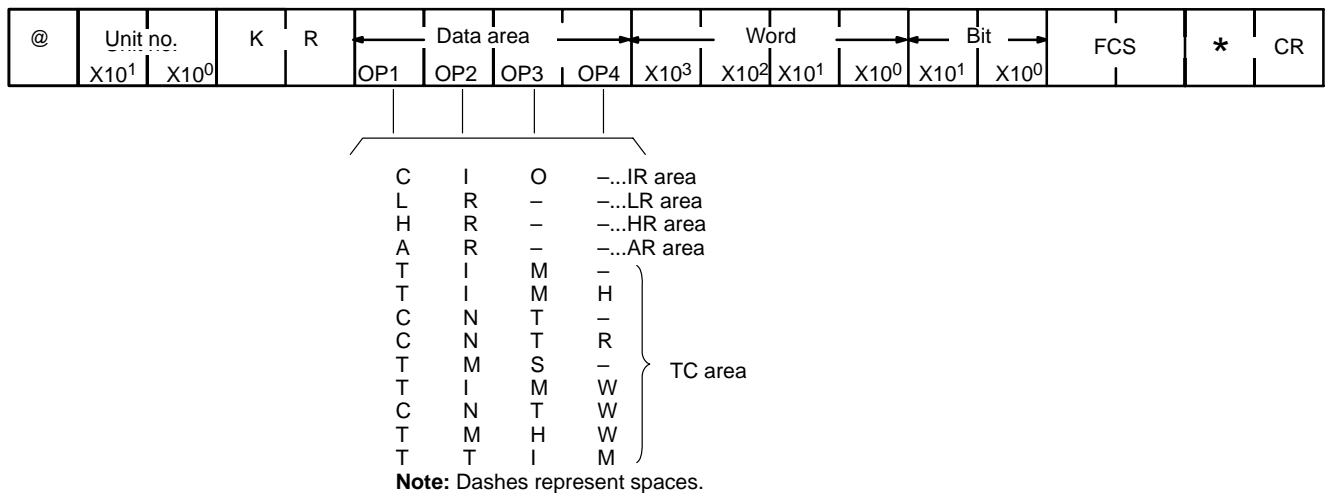

87Response Format

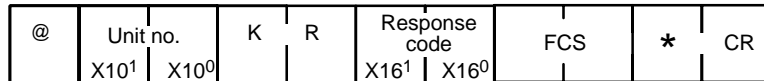

### 4-30 MULTIPLE FORCED SET/RESET

(C200H, C200HS, C200HX, C200HG, C200HE, and Mini H-type only.) This command force sets or resets bits in the IR, LR, HR, AR, or TC areas.

Command Format

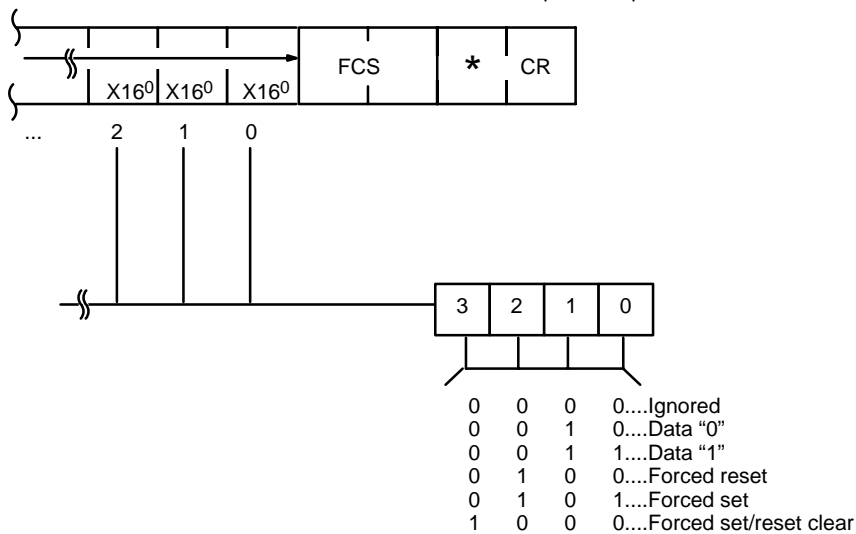
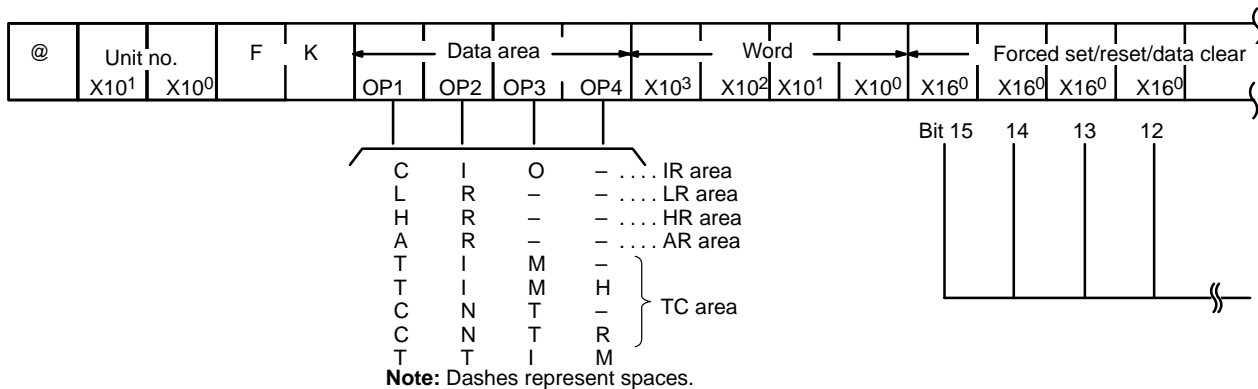

Response Format

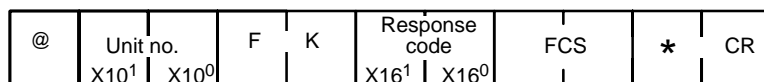

### 4-31 MULTIPLE FORCED SET/RESET STATUS READ

(C200H, C200HS, C200HX, C200HG, C200HE, and Mini H-type only.) Reads the forced set or forced reset status of the PC to which the specified Host Link Unit is mounted. When the operand is a timer/counter instruction (i.e., TIM(SP), TIMH, CNT(SP), CNTR, or TTIM), only the operands and words being force set/reset will be read.

**Command Format**



**Response Format**

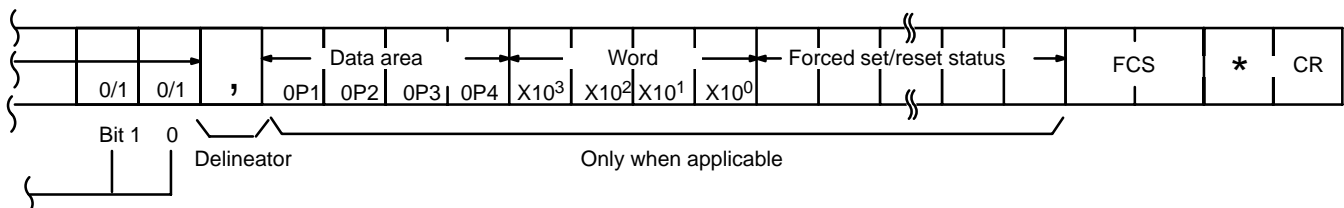
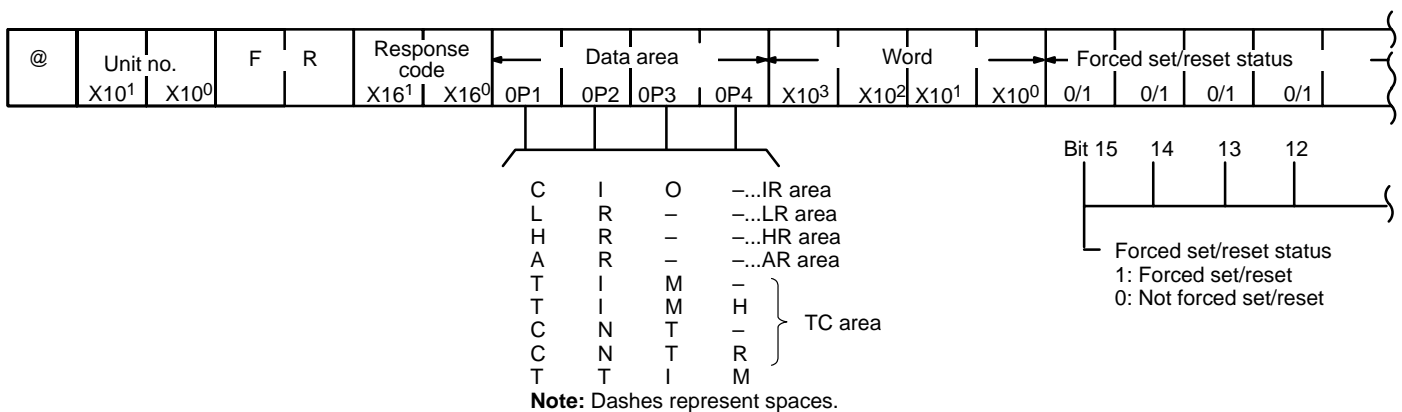

### 4-32 FORCED SET/RESET CANCEL

Cancels all forced set and forced reset bits (including those achieved via MULTIPLE FORCED SET/RESET for the C200H, C200HS, C200HX, C200HG, C200HE, and Mini H-type).

**Command Format**

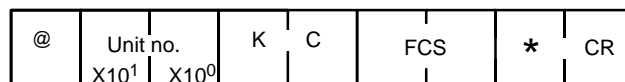

**Response Format**

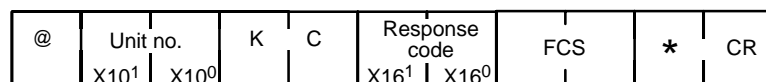

### 4-33 PC MODEL READ

Reads the model type of the PC.

**Command Format**

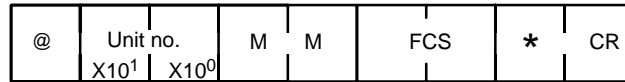

**Response Format**

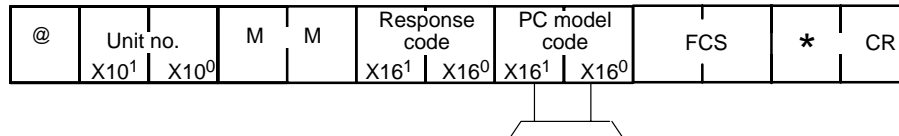

- 0 1 C250 or P-type
- 0 2 C500
- 0 3 C120
- 1 0 C1000H
- 1 1 C2000H
- 1 2 C200H/HS/HX/HG/HE

### 4-34 DM HIGH-SPEED READ

(C1000H and C2000H only) Reads a fixed group of eight DM area words at high-speed. The group of words to be read depends on the Host Link Unit and the PC as follows:

Host Link Unit		C1000H/C2000H
3G2A5-LK101-(P)EV1 3G2A5-LK201-EV1		Wd DM 0008 to 0015
C500-LK103(-P) C500-LK203	Operating level 0	Wd DM 0008 to 0015
	Operating level 1	Wd DM 0000 to 0007
3G2A6-LK101-(P)EV1 3G2A6-LK201-EV1 3G2A6-LK202-EV1		Wd DM 0016 to 0023

**Command Format**



**Response Format**

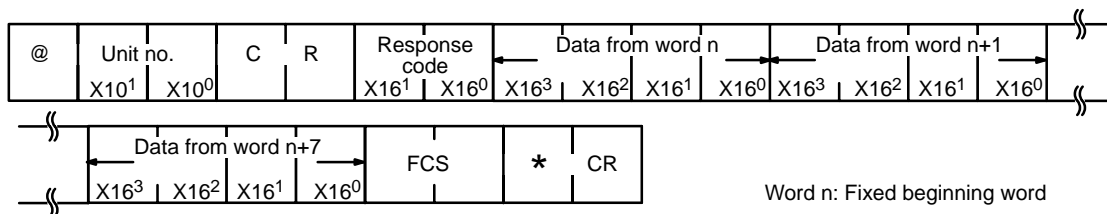

Response time is not affected by the operating mode of the PC or the cycle time. The response transmission begins less than 10 ms after the reception of the command.

## 4-35 ABORT and INITIALIZE

The ABORT command is used to abort the process being performed by the Host Link Unit and to then enable reception of the next command. The INITIALIZE command initializes the transmission control procedure of all the PCs connected to the host computer. Neither command receives a response.

A processing time of 100 ms is required between reception of the ABORT or INITIALIZE commands, and reception of the next command. If INITIALIZE is used in a single-link system, it will be regarded as undefined.

### ABORT Command Format

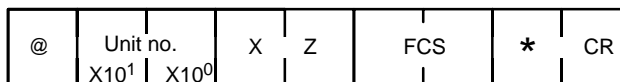

### INITIALIZE Command Format

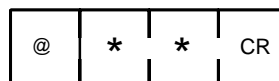

## 4-36 TRANSMIT (C200HS/HX/HG/HE only)

The Host Link Unit will transmit the specified data sent from the PC via the TXD (—) instruction in ASCII format. When the (TXD(—) instruction is executed in the ladder diagram, data is transmitted to the host computer in the following format. Refer to the *C200HS Operation Manual* or *C200HX/HG/HE Operation Manual* for further details on the TXD (—) instruction.

### Response Format

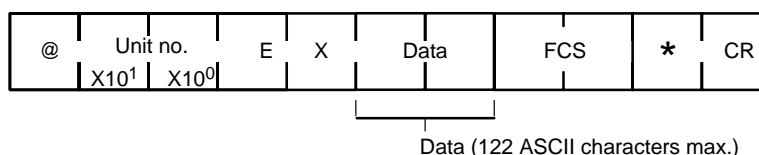

The data (61 bits maximum) specified in the operands of the TXD (—) instruction is converted into ASCII (122 characters maximum) and transmitted. There will be no response required from the host computer for TXD (—) instruction.

## 4-37 Response to an Undefined Command

This response is sent if the Host Link Unit cannot read the command's header code, or if the specified command is not valid for the command level or model of PC. If this response is received check the header code, command level, and PC model, then execute the correct command.

### Response Format

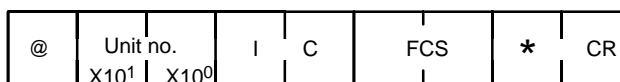

### 4-38 Response Indicating an Unprocessed Command

This response is sent when the Host Link Unit cannot process a command. The type of error encountered by the Host Link Unit can be identified via the response code.

**Response Format**

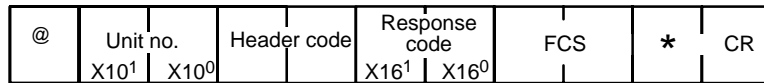

The header code varies according to the command which was sent. The headers of some commands include subheader codes (e.g., I/O REGISTER, I/O READ, and DM SIZE CHANGE).

### 4-39 PROGRAM READ

Transmits the contents of the PC program memory.

**Command Format**

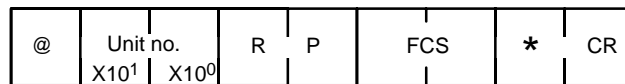

**Response Format**

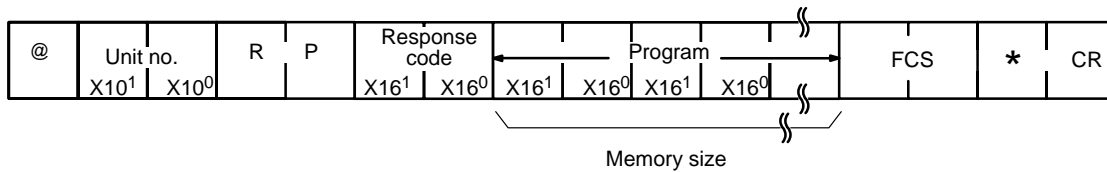

### 4-40 I/O TABLE READ

Reads the registered I/O table and the actual I/O table (i.e., the I/O Unit configuration connected to the PC).

**Command Format**



**Response Format**

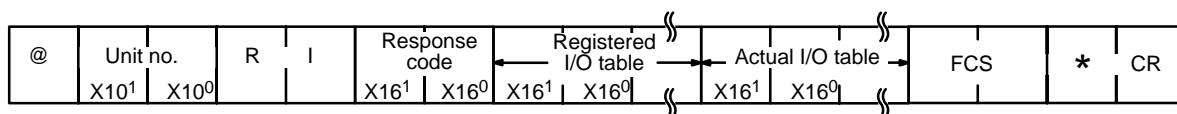

	<u>Registered I/O table</u>	<u>Actual I/O table</u>
C1000H/C2000H, C200H:	930	1408 characters
All others:	336	358

### 4-41 PROGRAM WRITE

Writes the received program into the PC program memory.

**Command Format**

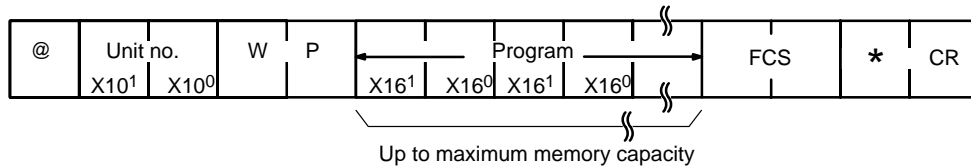

**Response Format**

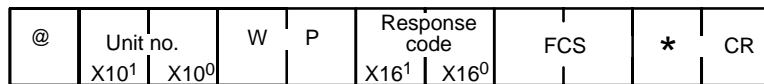

### 4-42 I/O TABLE GENERATE

Corrects the registered I/O table to match the actual I/O table.

**Command Format**

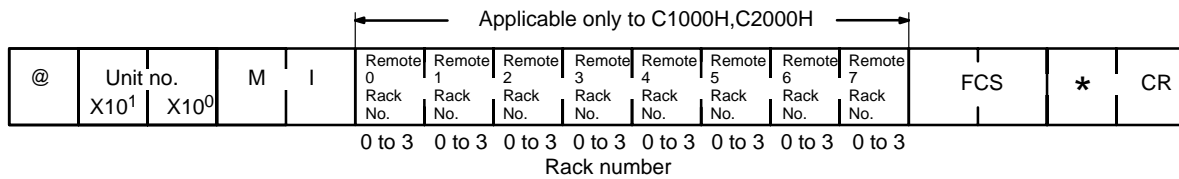

**Note** When the Rack number is to remain unspecified, assign an ASCII character other than 0 to 3 to it.

**Response Format**

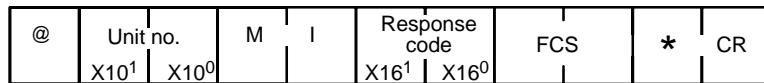

### 4-43 I/O REGISTER

Registers the IR, LR, HR, AR, or TC area bit, or the DM word that is to be read via I/O READ (described in the next subsection). Registered data is retained until new data is registered, or the power is turned OFF.

#### Command Format

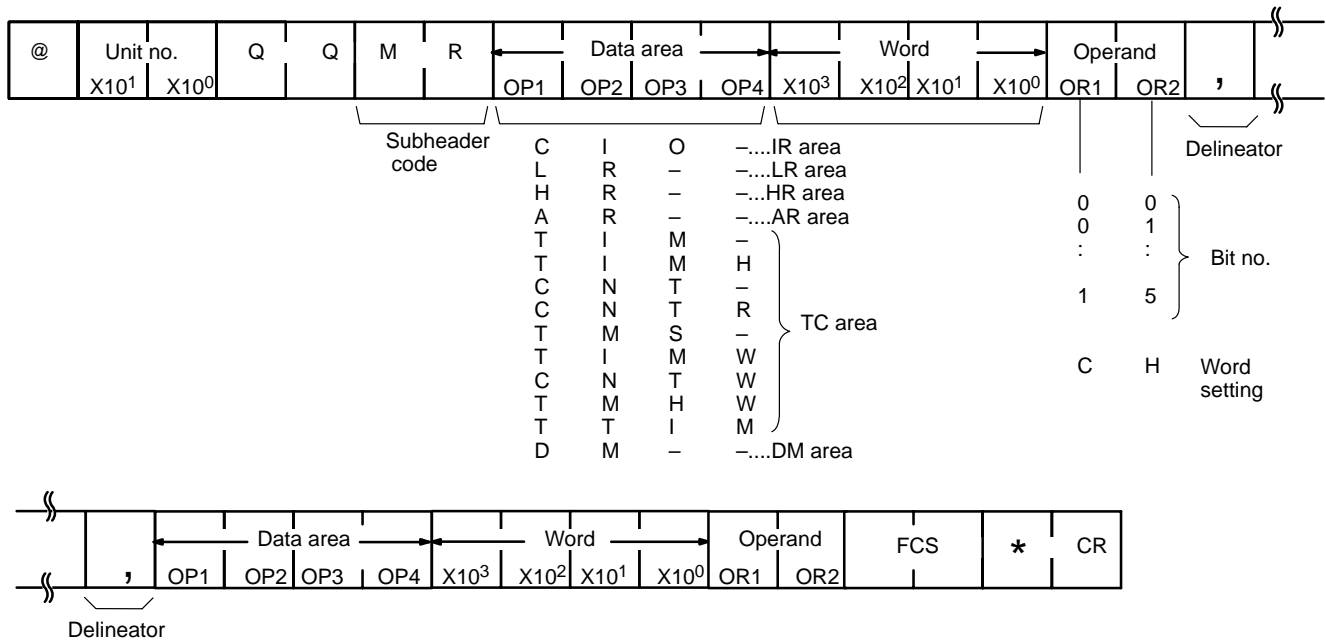

#### Setting Table

	Data Area	Word	Operand	Response
<b>Bit</b>	IR	0000 to max. Wd	00 to 15	ON/OFF status of specified bit
	LR	0000 to max. Wd	00 to 15	ON/OFF status of specified bit
	HR	0000 to max. Wd	00 to 15	ON/OFF status of specified bit
	AR	0000 to max. Wd	00 to 15	ON/OFF status of specified bit
	TIM/CNT	0000 to max. Wd	Anything other than "CH"	ON/OFF status of specified bit
<b>Wd</b>	IR	0000 to max. Wd	"CH"	Word contents
	LR	0000 to max. Wd	"CH"	Word contents
	HR	0000 to max. Wd	"CH"	Word contents
	AR	0000 to max. Wd	"CH"	Word contents
	TIM/CNT	0000 to max. Wd	"CH"	ON/OFF status of Completion Flag and PV
	DM	0000 to max. Wd	Any characters	Word contents

The maximum number of data items for the C120 and C500 PCs is 140; and for the C200H, C200HS, C200HX, C200HG, C200HE, C1000H, C2000H PCs the maximum is 128. However, the C200H, C200HS, C200HX, C200HG, C200HE, C1000H, C2000H PCs count the TC area word specification as two items.

The data is registered in the same sequence in which it was specified.

Response Format

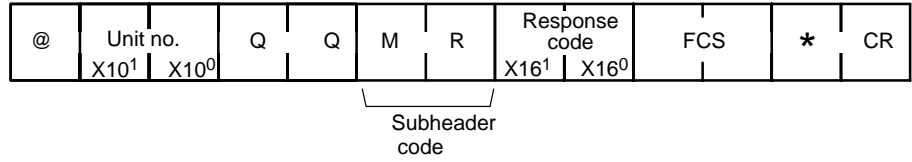

## 4-44 I/O READ

Reads the data specified by I/O REGISTER.

Command Format

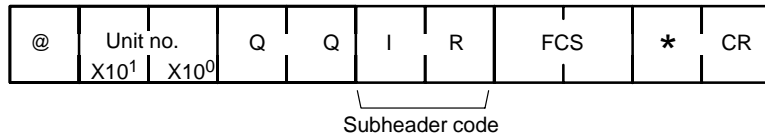

Response Format

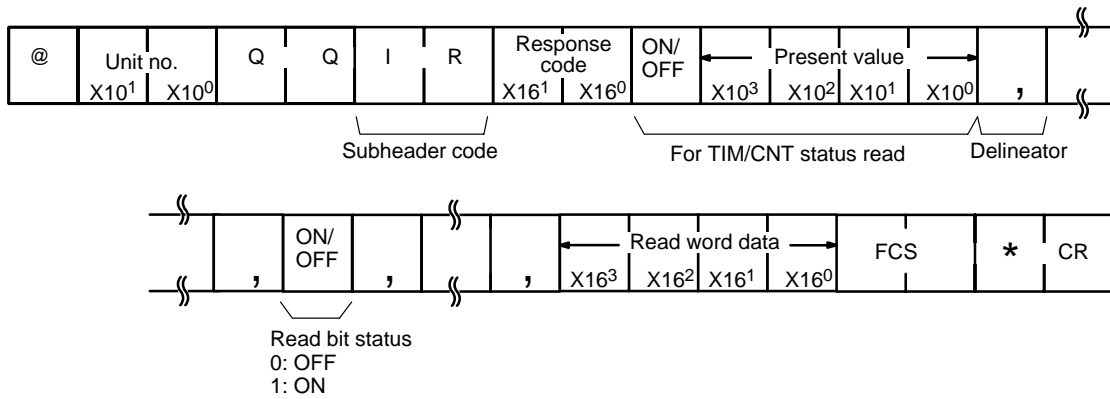

## 4-45 Response Code List

A response code is returned with each response to a command to indicate the results of executing the command. A response code of 00 indicates that the command was completed normally. All other response codes indicate errors that prevented proper command execution and tell something about the cause of the error.

x16 <sup>1</sup>	x16 <sup>0</sup>	Description
0	0	Command completed normally.
0	1	Execution was not possible because the PC is in RUN mode. Change the PC mode.
0	2	Execution was not possible because the PC is in MONITOR mode. Change the PC mode.
0	3	Execution was not possible because PROM is mounted. Change the unit to RAM or EEPROM.
0	4	Address overflow (data overflow). Check the program.
0	B	Execution was not possible because the PC is in PROGRAM mode. Change the PC mode.
0	C	Execution was not possible because the PC is in DEBUG mode. Change the PC mode.
0	D	Execution was not possible because the Host Link Unit's keyswitch is set to LOCAL mode or because the command was sent to a C2000H CPU that was on standby. Change the mode or send the command to the active CPU.
1	0	Parity error.
1	1	Framing error (stop bit(s) not detected).
1	2	Overrun (the next command was received too soon).
1	3	FCS error (checksum error).
1	4	Command format error.
1	5	An incorrect data area designation was made for READ or WRITE.
1	6	Instruction not found.
1	8	Frame length error (maximum length exceeded).
1	9	Execution was not possible because of an unexecutable error clear, memory error, EEPROM write disabled, etc.
2	0	I/O table generation was not possible (unrecognized Remote I/O Unit, word overflow, duplicated word allocation).
2	1	An error occurred in the PC's CPU.
2	2	The specified Memory Unit does not exist.
2	3	The specified Memory Unit is write-protected.
A	0	Aborted due to parity error in transmit data.
A	1	Aborted due to framing error in transmit data.
A	2	Aborted due to overrun in transmit data.
A	3	Aborted due to FCS (checksum) error in transmit data.
A	4	Aborted due to format error in transmit data.
A	5	Aborted due to entry number data error in transmit data.
A	8	Aborted due to frame length error in transmit data.
B	0	Not executable because the program area is not 16 kbytes.
Other		Remove any possible causes of noise and resend the command.

### 4-46 Communications Examples

The following are examples of commands from the host computer (first line) and the responses that would be given by the Host Link Unit (second line). The arrows indicate the transfer of the right to transmit.

#### Reading Data from Multiple PC Words (Wd IR 04 to 06) (Normal Completion)

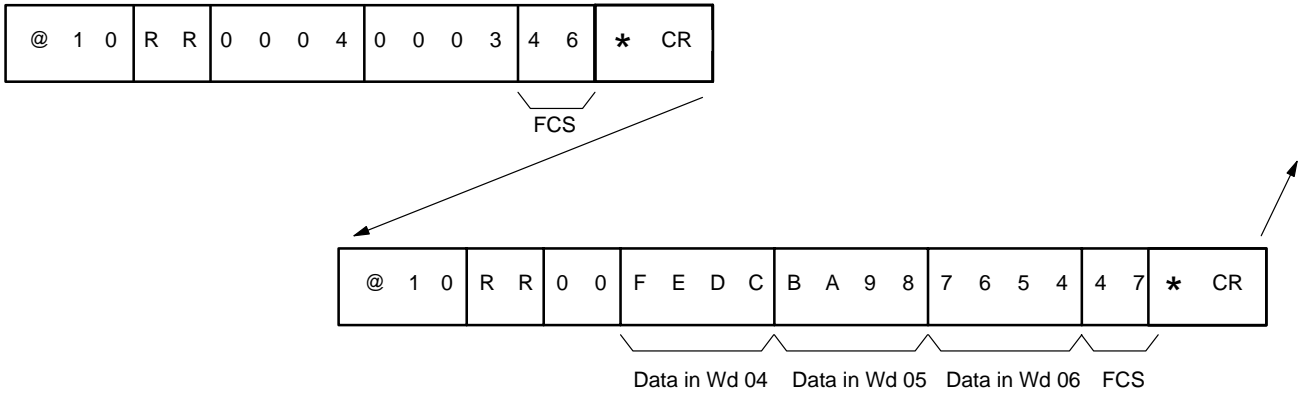

#### Wd 9000 Specified by Mistake in a DM AREA WRITE Command

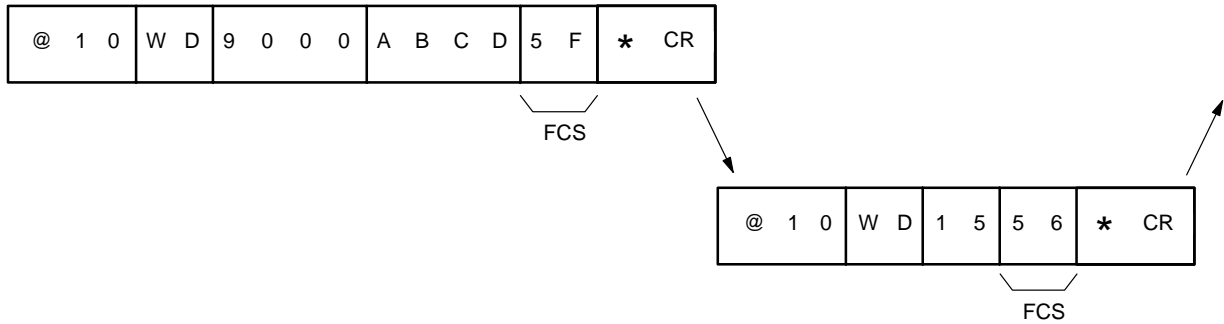

#### Header Code Destroyed During ERROR READ Operation

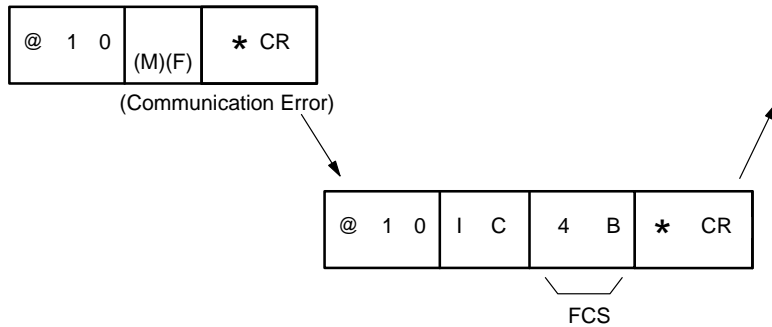

Writing Data into PC Words ("0123" to Wd DM 400 and "FEDC" to Wd DM 401) and Confirming with DM AREA READ.

@	1	0	W	D	0	4	0	0	0	1	2	3	F	E	D	C	5	2	*	CR
---	---	---	---	---	---	---	---	---	---	---	---	---	---	---	---	---	---	---	---	----

FCS

@	1	0	W	D	0	0	5	2	*	CR
---	---	---	---	---	---	---	---	---	---	----

FCS

@	1	0	R	D	0	4	0	0	0	0	0	2	5	1	*	CR
---	---	---	---	---	---	---	---	---	---	---	---	---	---	---	---	----

FCS

@	1	0	R	D	0	0	0	1	2	3	F	E	D	C	5	3	*	CR
---	---	---	---	---	---	---	---	---	---	---	---	---	---	---	---	---	---	----

FCS

# SECTION 5

## Error Processing

This section describes errors that can occur in a computer-linked system employing one or more Host Link Units and how to remedy them.

- 5-1 Development of an Error-processing Program .....
- 5-2 Error Control .....
- 5-2-1 Invalid Processing .....
- 5-2-2 Process Interruption .....
- 5-2-3 Time Monitoring .....
- 5-2-4 Retries .....
- 5-3 Example Host Computer Program .....
- 5-4 Troubleshooting .....

## 5-1 Development of an Error-processing Program

Errors that occur in Host Link systems are classified into the following three categories:

- 1, 2, 3... 1. Errors indicated by the Host Link Unit (see 5-4 *Troubleshooting*).
2. Errors processed by the PC (see the *Restart and Error Flags* sub-section for each group of models in *Section 2 Host Link Unit Characteristics*).
3. Errors processed by the host computer (see 5-2 *Error Control*, 3-2 *Communications Protocol*, and all of *Section 4 Commands and Responses*, especially 4-35 *ABORT and INITIALIZE*, and 4-45 *Response Code List*).

Programs to monitor communication times and error handling need to be developed on the host computer. Be sure that these include processes that can respond appropriately to errors and other abnormalities from the PC by taking into consideration the kinds of errors described in the sections listed above. An example of the logic processes that need to be considered is given in the in the following flow-chart.

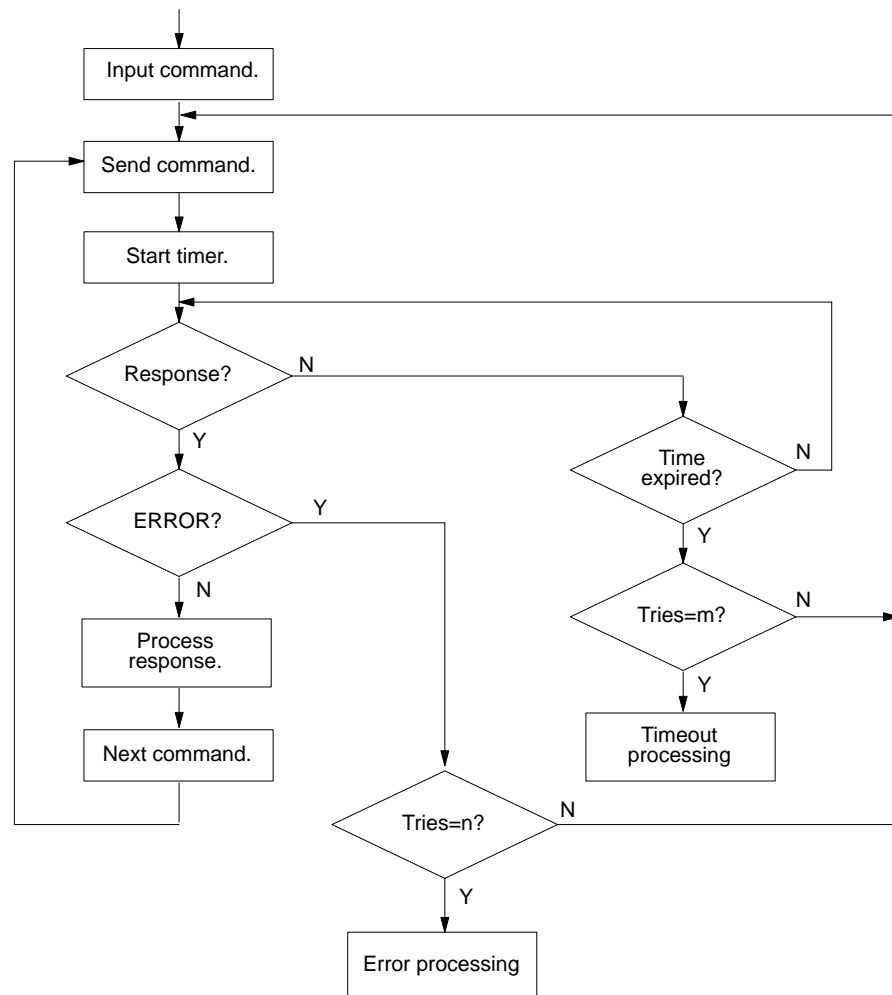

## 5-2 Error Control

The host computer is responsible for ensuring system recovery after errors occur in the Host Link Unit.

The Host Link Unit runs the following checks to detect errors:

- 1, 2, 3...
1. Parity check
  2. Framing check
  3. Overrun check
  4. Format check
  5. Entry data check (The start word, read word, etc., in the command format.)
  6. Frame Checksum (An Exclusive OR check is performed on all command or response data, from the unit number to the end of the text.)

Of the above commands, 1 to 3 are performed on a character by character basis. Checks 4 to 6, however, are performed on each block (frame).

Transmit data in a multiple-link system is checked by means of a parity check and a Frame Checksum (FCS). The FCS check is not performed in single-link systems.

### 5-2-1 Invalid Processing

If the Host Link Unit detects an error in a single-frame command or the first frame of a command block, it will regard the command as invalid. The command will not be processed and, after the terminator is received, an error response will be sent to the host computer. (For details of the error response, refer to *4-38 Response Indicating an Unprocessed Command*.)

### 5-2-2 Process Interruption

If the Host Link Unit detects an error in an intermediate frame, the commands up to that point will be processed normally. Those following the erroneous frame, however, will not be processed. After the Host Link Unit has received the terminator of the erroneous block, it responds with a response code that informs the host computer of the process interruption. (For details, refer to *4-45 Response Code List*.)

### 5-2-3 Time Monitoring

If the Host Link Unit does not receive a delimiter or terminator, it cannot send a response to the host computer. Similarly, if the computer does not receive a delimiter or terminator, it cannot transmit further commands to the Host Link Unit. To allow transmission to alternate smoothly between the computer and the Host Link Unit, the process times need to be monitored. It is therefore necessary to have a time-monitoring program on the host computer side. Its purpose is to initiate remedial action if the right to transmit is not transferred quickly enough.

### 5-2-4 Retries

An error response will be returned to the originating device if the Host Link Unit detects any communications line data that has been destroyed (e.g., by noise). If, however, the Unit number has also been lost, no response will be made at all. It is therefore necessary to have response monitoring and retry processing in the host computer to check for error responses.

## 5-3 Example Host Computer Program

This example program causes arbitrary data to be written from the host computer to DM 0001. A timer is included to retry transmission if the timer times out. An error message is displayed after 3 time outs.

- OMRON FC-986 Host Computer  
Host Link Unit:  
C200H-LK101-PV1/LK201-V1/LK202-V1  
3G2A5-LK101-(P)EV1/LK201-EV1/LK103-(P)  
C500-LK203  
3G2A6-LK101-(P)EV1/LK201-EV1/LK202-EV1

```

10 OPEN "CQM1:E37NN" AS #1 . . . . . Opens RS-232C
20 NG=0:I=0:CNT=0
30 INPUT "TEST DATA INPUT-----";TD$ . . Inputs test data.
40 TC$="@00WD0001"
50 TC$=TC$+TD$
60 GOSUM *FCSSET . . . . . Calculates FCS.
70 TXD$=T$+FCS$+"*"+CHR$(13)
80 PRINT "TXD$=";TXD$
90 PRINT #1,TXD$; . . . . . Transmission
100 IF LOC(1)<>0 GOTO 140 . . . . . Determines whether data was received.
110 CNT=CNT+1
120 IF CNT=1000 GOTO 1000 . . . . . The value of CNT determines the timer setting.
130 GOTO 100
140 INPUT #1,RXD$
150 R$=MID$(RXD$,6,2)
160 IF R$<>"00" GOTO 2000 . . . . . Determines whether communications were completed normally.
170 PRINT "RXD$=";RXD$+"          OK"
180 GOTO 20
1000 REM *****TIME UP*****
1005 CNT=0
1020 ER$(NG)="TIME UP"
1025 NG=NG+1
1030 IF NG=3 GOTO 3000 . . . . . Sets 3 retries.
1040 GOTO 80
2000 REM *****ERROR RESPONSE*****
2020 ER$(NG)=RXD$+"          NG"
2025 NG=NG+1
2030 IF NG=3 GOTO 3000 . . . . . Sets 3 retries.
2040 GOTO 80
3000 REM *****ERROR MESSAGE*****
3010 PRINT "AN ERROR OCCURRED"
3020 PRINT "RXD$-1=";ER$(0)
3030 PRINT "RXD$-2=";ER$(1)
3040 PRINT "RXD$-3=";ER$(2)
3050 GOTO 20
4000 REM *****FCS CALCULATION*****
4010 *FCSSET
4020 L=LEN(T$)
4030 A=0
4040 FOR J=1 TO L
4050 TJ$=MID$(T$,J,1)
4060 A=ASC(TJ$) XOR A
4070 NEXT J
4080 FCS$=HEX$(A)

```

```
4090 IF LEN(FCS$)=1 THEN FCS$="0"+FCS$
4100 RETURN
```

## 5-4 Troubleshooting

The following troubleshooting guide outlines the basic steps for remedying the errors most likely to occur when using Host Link Units.

Problem		Possible Cause	Remedy	Reference
RUN indicator does not light. (When power is applied to the Host Link Unit, and the reset is released, the indicator should illuminate.)		Power is not applied to the PC. Faulty contact in the connector between the PC and the Host Link Unit. PC is resetting the Host Link Unit. Host Link Unit is defective.	Apply power to the PC. Check and repair connections. Turn the PC OFF, then ON. If necessary, check the PC for an error or abnormal reset. Replace the Host Link Unit.	
RCV indicator does not blink. (When a signal is input at the receive connector, the indicator should blink regardless of the nature of the signal.)		No signal is being output from the host computer. The signal from the host computer is not reaching the Host Link Unit. The indicator circuit is defective.	Check the program and output of the host computer. Check the wiring: <ul style="list-style-type: none"> <li>• Cable not connected?</li> <li>• Cable damaged?</li> <li>• Cable incorrectly connected?</li> <li>• Faulty contact in connector?</li> </ul> If the signal is being transmitted and received normally, the Host Link Unit is faulty and needs to be replaced.	Sections 1 and 2
XMT indicator does not illuminate after the RCV indicator. (If the Unit number on the computer side matches that of the Host Link Unit, the Host Link Unit receives the terminator, the CTS signal then goes ON, and the Host Link Unit sends data irrespective of its nature.)		The unit numbers of the computer and the Host Link Unit do not match. The Host Link Unit is not receiving a terminator. The signal is ignored because the Host Link Unit cannot correctly read it. <ul style="list-style-type: none"> <li>• Transmission speeds of the host computer and the Host Link Unit do not match.</li> <li>• Incorrect wiring.</li> <li>• Incorrect setting for the termination resistance.</li> </ul> Parities or transmission codes don't match. Error in operating level setting.	Check the unit number settings. Check whether the host computer is outputting a terminator. Check the settings of the Host Link Unit and the Link Adapter. Check the wiring for the CTS signal. Check the parity or transmission code settings. Check the operating level settings.	Section 2  Section 1 Section 2
ERR indicator illuminates.		Parity error (even parity). Framing error. Overrun error. Occurrence of momentary power failure.	Send correct data. If a momentary power failure occurs, both the PC and the Host Link Unit are reset and initialized. The ERRor indicator will turn off.	Sections 2 and 3
Although the XMT indicator illuminates, the Host Link Unit cannot send a response to the host computer.		Operation error on the host computer side. <ul style="list-style-type: none"> <li>• I/O channel processing error.</li> <li>• Program error.</li> </ul> The correct signal is not reaching the host computer. <ul style="list-style-type: none"> <li>• Cable damage.</li> <li>• Incorrect cable wiring.</li> <li>• Faulty contact in connector.</li> </ul>	---	Section 2
RUN indicator blinking.	Error indicator not lit.	Error in unit number, transmission speed, command level, parity, or transmission code setting.	Correct the setting and restart the Host Link Unit.	Section 2
(C200H-LK101-PV1/ LK201-V1/ LK202-V1 only)	Error indicator lit.	Error detected between the Host Link Unit and CPU.	Turn power off and then back on. Replace the Host Link Unit.	

# Appendix A

## Standard Models

Product	Description	Model Number
Host Link Unit	C200H Rack-mounting (two per PC) (APF/PCF/H-PCF)	C200H-LK101-PV1
		C200H-LK201-V1
		C200H-LK202-V1
	C500 Rack-mounting (one per PC)	3G2A5-LK101-PEV1
		3G2A5-LK101-EV1
		3G2A5-LK201-EV1
	C500 Rack-mounting (two per PC) (APF/PCF/H-PCF)	C500-LK103-P
		C500-LK103
		C500-LK203
	CPU-mounting (APF/PCF/H-PCF)	3G2A6-LK101-PEV1
		3G2A6-LK101-EV1
		3G2A6-LK201-EV1
		3G2A6-LK202-EV1
Link Adapter	RS-422 (3 connectors)	3G2A9-AL001
	Optical (PCF/H-PCF) (3 connectors)	3G2A9-AL002-E
	Optical (APF/PCF/H-PCF) (3 connectors)	3G2A9-AL002-PE
	Optical (PCF/H-PCF), RS-232C, RS-422 (1 connector each)	3G2A9-AL004-E
	Optical (APF/PCF/H-PCF), RS-232C, RS-422 (1 connector each)	3G2A9-AL004-PE
	Optical (PCF/H-PCF), optical (AGF) (1 connector each)	3G2A9-AL005-E
	Optical (APF/PCF/H-PCF), optical (AGF) (1 connector each)	3G2A9-AL005-PE
	Optical (PCF/H-PCF) (1 connector), optical (AGF) (2 connectors)	3G2A9-AL006-E
	Optical (APF/PCF/H-PCF) (1 connector), optical (AGF) (2 connectors)	3G2A9-AL006-PE

## Optical Interface

(Used to interface C500-LK203, 3G2A5-LK201-EV1, and 3G2A6-LK201-EV1 Host Link Units.)

Product	Description	Model Number
Optical Interface	RS-232C to optical converter	Z3RN-A-5
Optical Fiber Cable	1, 5, 10, 20, 30, 50, 100, 200, 400, or 500 m. (Replace "□" in model number with the desired cable length)	Z3F2-4D□M
AC Adapter	For Optical Interface power supply. One required for C500-LK203; two for 3G2A5-LK201-EV1 or 3G2A6-LK201-EV1 Host Link Units.	Z3GP-01

## Connecting Cable

RS-422 and RS-232C connecting cables must be provided by the user.

## I/O Cables

RS-422 and RS-232C connecting cables must be provided by the user.

Type	Connector	Connector cover	Maker
RS-232C	XM2A-2501	XM2S-2511	OMRON
	DB-25P	DB-C2-J9	JAE
RS-422	XM2A-0901	XM2S-0911	OMRON
	DE-9E	DE-C1-J6	JAE

## Plastic Optical Fiber Cable

Host Link Units with the suffix -P in the model number can be extended up to 20 m. The optical connector of the 3G5A2-PF002 must be supplied by the user.

Product	Description	Model Number
Plastic optical fiber cable	Cable only (without optical connector). Order in multiples of 5 m (from 5 to 100 m), or in lengths of 200 m or 500 m.	3G5A2-PF002
Optical connector A	2 Optical connectors (brown). For plastic optical fiber cable 8 to 20 m long.	3G5A2-CO001
Optical connector B	2 Optical connectors (black). For plastic optical fiber cable 8 to 20 m long.	3G5A2-CO002
Plastic optical fiber set	1 m cable with connector 'A' attached.	3G5A2-PF101

## Hard-clad Plastic Optical Fiber (H-PCF)

Product	Description	Model Number
Hard-clad plastic optical fiber (H-PCF)	Two-core optical cord type. Length: 1,000 m; color: black	S3200-HBCB103
	Two-core optical cord type. Length: 10 m; color: black	S3200-HBCB101
	Two-core optical cord type. Length: 50 m; color: black	S3200-HBCB501
	Two-core optical cord type. Length: 100 m; color: black	S3200-HBCB102
	Two-core optical cord type. Length: 500 m; color: black	S3200-HBCB502
	Without tension member type (for fit). Length: 10 m; color: orange	S3200-HCCO101N
	Without tension member type (for fit). Length: 50 m; color: orange	S3200-HCCO102N
	Without tension member type (for fit). Length: 100 m; color: orange	S3200-HCCO501N
	Without tension member type (for fit). Length: 500 m; color: orange	S3200-HCCO502N
	Without tension member type (for fit) Length: 1,000 m; color: orange	S3200-HCCO103N
	With tension member type (for fit). Length: 10 m; color: black	S3200-HCCB101
	With tension member type (for fit) Length: 50 m; color: black	S3200-HCCB501
	With tension member type (for fit). Length: 100 m; color: black	S3200-HCCB102
	With tension member type (for fit). Length: 500 m; color: black	S3200-HCCB502
	With tension member type (for fit). Length: 1,000 m; color: black	S3200-HCCB103
	With tension member type (for fit). Length: 10 m; color: orange	S3200-HCCO101
	With tension member type (for fit). Length: 50 m; color: orange	S3200-HCCO501
	With tension member type (for fit). Length: 100 m; color: orange	S3200-HCCO102
	With tension member type (for fit). Length: 500 m; color: orange	S3200-HCCO502
With tension member type (for fit) Length: 1,000 m; color: orange	S3200-HCCO103	
Optical connector	SYSMAC BUS or SYSMAC WAY connector	S3200-COCH82
Optical power tester	SYSMAC BUS or SYSMAC WAY optical characteristics measurement power tester	S3200-CAT2820
Head set	SYSMAC BUS or SYSMAC WAY optical power tester head set	S3200-CAT2822
Master fiber set	SYSMAC BUS or SYSMAC WAY optical power tester master fiber	S3200-CAT2821

### Note

In the case of SYSMAC WAY and SYSMAC BUS, the maximum available length between units is 200 m.

## Plastic-clad Optical Fiber Cable

Host Link Units with the suffix -P in the model number can be extended up to 200 m by using plastic-clad optical fiber cable. Those without the suffix -P in the model number can be extended up to 800 m.

Cable Type	Description	Operating Environment	Model Number
Indoor	0.1 m, with connector	Operating temperature: $-10^{\circ}$ to $70^{\circ}\text{C}$	3G5A2-OF011
	1 m, with connector		3G5A2-OF101
	2 m, with connector		3G5A2-OF201
	3 m, with connector		3G5A2-OF301
	5 m, with connector		3G5A2-OF501
	10 m, with connector		3G5A2-OF111
	20 m, with connector		3G5A2-OF211
	30 m, with connector		3G5A2-OF311
	40 m, with connector		3G5A2-OF411
	50 m, with connector		3G5A2-OF511
Indoor/outdoor	1 to 500 m, with connector (order in multiples of 1 m)	Operating temperature: $-10^{\circ}$ to $70^{\circ}\text{C}$	3G5A2-OF002
	501 to 800 m, with connector (order in multiples of 1 m)	Operating temperature: $0^{\circ}$ to $55^{\circ}\text{C}$ (Do not expose to direct sunlight)	

### Note

Since the optical fiber cable cannot be spliced as easily as ordinary cables when damaged or extended, be sure to install an adequate length. The cable lengths above do not include connectors.

## Crystal Fiber Cable (AGF)

Crystal fiber cable is not available from OMRON. It must be obtained from an alternative supplier.

# Appendix B Specifications

## Communications

<b>Communications</b>	2-fiber, half duplex: -LK10□ models 4-wire, half duplex: -LK20□ models
<b>Synchronization</b>	Start/stop: 1 stop bit (JIS) or 2 bits (ASCII)
<b>Transmission speed</b>	300, 600, 1,200, 2,400, 4,800, 9,600, or 19,200 bps (switch-selectable)
<b>Character code</b>	ASCII (7 bits) or JIS (8 bits)
<b>Error check</b>	Parity and FCS
<b>Interface*</b>	Optical fiber: -LK10□ models RS-232C, RS-422: -LK20□ models

\*Model numbers indicate the maximum transmission distance as given in the following tables.

## Transmission Distance

### Optical Fiber Cables

Model Number	APF	H-PCF	PCF
C200H-LK101-PV1	20 m	100 m	200 m
3G2A5-LK101-PEV1	20 m	100 m	200 m
3G2A6-LK101-PEV1	20 m	100 m	200 m
C500-LK103-P	20 m	100 m	200 m
3G2A5-LK101-EV1	Cannot be connected	200 m	800 m
3G2A6-LK101-EV1	Cannot be connected	200 m	800 m
C500-LK103	Cannot be connected	200 m	800 m

### Wire Cables

Model Number	Interface	Transmission Distance
C200H-LK202-V1	RS-422	10 m/branch (500 m total*)
C200H-LK201-V1	RS-232C	15 m
3G2A5-LK201-EV1	RS-232C	15 m
C500-LK203	RS-422	10 m/branch (500 m total*)
3G2A6-LK201-EV1	RS-232C	15 m
3G2A6-LK202-EV1	RS-422	10 m/branch (500 m total*)

\*Total in the system.

## Weight

C200H-LK101-PV1 C200H-LK201-V1 C200H-LK202-V1	400 g max.
3G2A5-LK101-(P)EV1 3G2A5-LK201-EV1 C500-LK103(-P) C500-LK203	800 g max.
3G2A6-LK101-(P)EV1 3G2A6-LK201-EV1 3G2A6-LK202-EV1	600 g max.

### Power Consumption

C200H-LK101-PV1 C200H-LK201-V1* C200H-LK202-V1	0.25 A max. at 5 VDC
3G2A5-LK101-(P)EV1 3G2A5-LK201-EV1 C500-LK103(-P) C500-LK203* 3G2A6-LK101-(P)EV1 3G2A6-LK201-EV1 3G2A6-LK202-EV1	1 A max. at 5 VDC

\*Internal power consumption increases by 0.1 A when using the Z3RN-A-5.

### Host Link Unit Dimensions

#### C200H

All C200H Units have dimensions as given below.

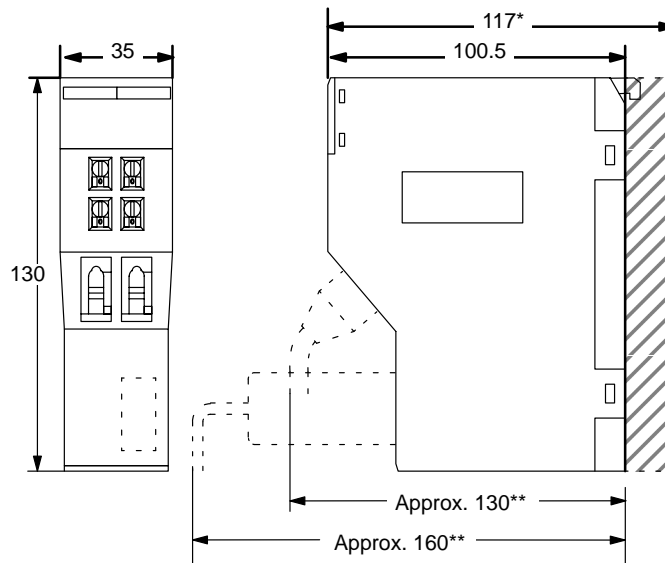

\* Including backplane  
\*\* Including Connector