

# CJ series Position Control Units

# CJ1W-NC□□3

CSM\_CJ1W-NC\_DS\_E\_8\_5

## High-speed, High-precision positioning with 1, 2, or 4 axes

- Versatile functions and superb performance enable the construction of compact, high-performance machines.
- With its ultra-compact size of 31 × 90 mm (W × H), this highly space-efficient Position Control Unit (PCU) enables up to 4 axes of motor control.



## Features

- Two types to choose from: open collector output and line driver. Because both open collector output and line driver types feature 1-, 2-, and 4-axis models, the most appropriate model can be selected for the application at hand.
- Positioning START occurs within 2 ms (maximum speed) after receiving a command from the Programmable Controller. (Refer to the Operation Manual for conditions.)
- High-speed data transfer is possible using INTELLIGENT I/O WRITE (IOWR) and INTELLIGENT I/O READ (IORD) instructions.
- Fine control from low to high speed (500 kpps max.) is possible in 1-pps units.
- Positioning can be done from memory, by writing an operating pattern into the PCU memory in advance. Three position patterns – Terminating, Automatic, and Continuous – can be set with completion codes to respond to a wide range of operations. Positioning of up to 100 patterns (sequential data) per one axis can be possible.
- Positioning (direct operation) can be done by direct PLC ladder commands for position data, speed data, and acceleration data. This simplifies control in situations when the target position and speed cannot be decided until immediately before operation begins, or when the target position and speed change due to other circumstances. The target position and speed can also be changed during operation.
- Interrupt feeding moves the axis a specified amount, then stops it, in accordance with an interrupt input. High-speed (0.1 ms max.) processing of the interrupt input signal ensures high-precision interrupt positioning. This helps to maximize feeder precision.
- Easy-to-Use positioning can be possible with versatile functions such as Teaching, Override, Backlash compensation, Zones, Forced interrupt and Acceleration/Deceleration curve.

## System Configuration

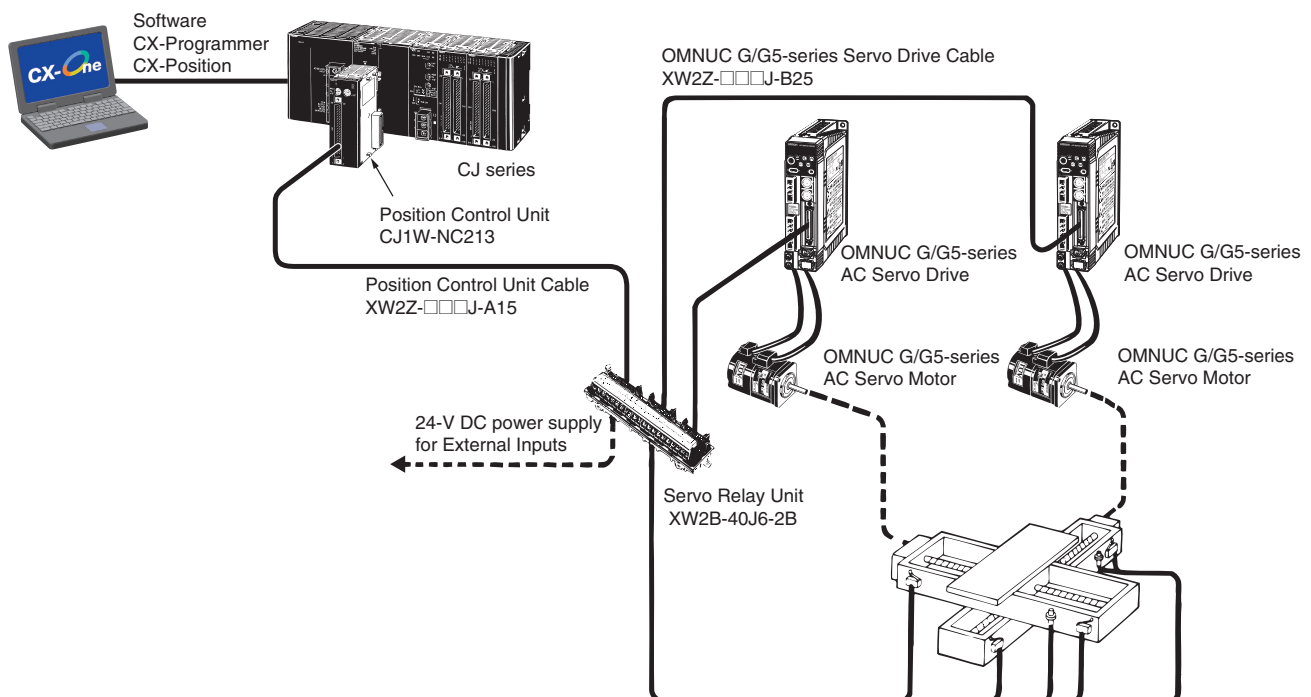

## Ordering Information

### International Standards

- The standards are abbreviated as follows: U: UL, U1: UL(Class I Division 2 Products for Hazardous Locations), C: CSA, UC: cULus, UC1: cULus (Class I Division 2 Products for Hazardous Locations), CU: cUL, N: NK, L: Lloyd, and CE: EC Directives.
- Contact your OMRON representative for further details and applicable conditions for these standards.

## Position Control Unit

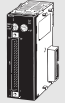
Unit type	Name	Specifications		No. of unit numbers allocated	Current consumption (A)		Model	Standards
		Control method/Control output interface	Number of control axes		5 V system	24 V system		
CJ1 Special I/O Units	Position control unit 	Open-loop control by pulse train output/ Open-collector output	1 axis	1	0.25	–	CJ1W-NC113	UC1, CE
			2 axes		0.25	–	CJ1W-NC213	
			4 axes *		0.36	–	CJ1W-NC413	
		Open-loop control by pulse train output/ Line-driver output	1 axis	1	0.25	–	CJ1W-NC133	
			2 axes		0.25	–	CJ1W-NC233	
	4 axes *		0.36		–	CJ1W-NC433		
Space Unit	The ambient operation temperature range can be increased to 0 to 55°C if the CJ1W-SP001 CJ-series Space Unit is used.					CJ1W-SP001	UC1, CE	

**Note:** This unit cannot be used with the Machine Automation Controller NJ-series.

\* The ambient operating temperature of the CJ1W-NC413/NC433 is 0 to 50°C. Allowable power supply voltage range for external power supply is 22.8 to 25.2 V DC.

## Software

Name	Specifications	Number of licenses	Model	Standards
FA Integrated Tool Package CX-One Ver. 4. □	The CX-One is a comprehensive software package that integrates Support Software for OMRON PLCs and components. CX-One runs on the following OS. OS: Windows XP (Service Pack 3 or higher, 32-bit version) / Windows Vista (32-bit/64-bit version) / Windows 7 (32-bit/64-bit version) / Windows 8 (32-bit/64-bit version) / Windows 8.1 (32-bit/64-bit version) / Windows 10 (32-bit/64-bit version)  CX-One Ver.4. □ includes CX-Position Ver.2. □. For details, refer to the CX-One catalog (Cat. No.R134).	1 license * DVD	CXONE-AL01D-V4	–

\* Multi licenses (3, 10, 30, or 50 licenses) and DVD media without licenses are also available for the CX-One.



## Servo Relay Unit/Cables

Name	Applicable units	Applicable drives	Number of control axes	Cable length	Model	Standards	
Servo Relay Unit	For CJ1W-NC113/133 (No communication supported)	–	1 axis	–	XW2B-20J6-1B	–	
	For CJ1W-NC213/233/413/433 (No communication supported)	–	2 axes	–	XW2B-40J6-2B	–	
	For CJ1W-NC113/133/213/233/413/433 (Communication supported)	–	2 axes	–	XW2B-40J6-4A	–	
Position Control Unit Cables for Servo Relay Unit	Open-collector output	For CJ1W-NC113	1 axis	0.5m	XW2Z-050J-A14	–	
				1m	XW2Z-100J-A14		
				0.5m	XW2Z-050J-A16		
		1m		XW2Z-100J-A16			
		For CJ1W-NC213/413		2 axes	0.5m		XW2Z-050J-A15
					1m		XW2Z-100J-A15
	0.5m		XW2Z-050J-A17				
	1m	XW2Z-100J-A17					
	Line-driver output	For CJ1W-NC313	1 axis		0.5m		XW2Z-050J-A18
					1m		XW2Z-100J-A18
				0.5m	XW2Z-050J-A20		
		1m		XW2Z-100J-A20			
For CJ1W-NC233/413		2 axes		0.5m	XW2Z-050J-A19		
				1m	XW2Z-100J-A19		
	0.5m		XW2Z-050J-A21				
1m	XW2Z-100J-A21						

## Accessories

The Position Control Unit includes the 40-pin solder-type connectors C500-CE404 (socket: Fujitsu FCN-361J040-AU, cover: Fujitsu FCN-360C040-J2).

## Applicable Connectors

Name		Specifications	Model	
External I/O Connectors		40 pin, soldered, right angle w/cover (included with the Unit)	C500-CE404	
		40 pin, crimped right angle w/cover	C500-CE405	
		40 pin, Pressure welded, w/o cover	C500-CE403	
			40 pin, soldered, w/cover	C500-CE401
			40 pin, crimped w/cover	C500-CE402

## Mountable Racks

Model	NJ system		CJ system (CJ1, CJ2)		CP1H system	NSJ system *1	
	CPU Rack	Expansion Rack	CPU Rack	Expansion Backplane	CP1H PLC	NSJ Controller	Expansion Backplane
CJ1W-NC113/133/213/233/413/433	Not supported		10 Units	10 Units (per Expansion Backplane)	2 Units *2	Not Supported	8 Units

\*1. Product no longer available to order.

\*2. CJ Unit Adapter CP1W-EXT01 required.

## Specifications

### Basic Specifications

Item	Model		
	CJ1W-NC113/133	CJ1W-NC213/233	CJ1W-NC413/433
Power supply voltage	5 V DC (for the PCU itself)		
	24 V DC (external power supply)		
	5 V DC (external power supply; line driver output only)		
Allowable power supply voltage range	4.75 to 5.25 V DC (for the PCU itself)		
	21.6 to 26.4 V DC (external power supply)		22.8 to 25.2 V DC (external power supply)
	4.75 to 5.25 V DC (external power supply; line driver output only)		
Internal current consumption	250 mA max. at 5 V DC	250 mA max. at 5 V DC	360 mA max. at 5 V DC
Current consumption of external power supply	NC113: 30 mA max. at 24 V DC NC133: 10 mA max. at 24 V DC NC133: 60 mA max. at 5 V DC	NC213: 50 mA max. at 24 V DC NC233: 20 mA max. at 24 V DC NC233: 120 mA max. at 5 V DC	NC413: 100 mA max. at 24 V DC NC433: 30 mA max. at 24 V DC NC433: 230 mA max. at 5 V DC
External dimensions	90 (H) × 31 (W) × 65 (D) (all models)		
Weight	100 g max.	100 g max.	150 g max.
Ambient operating temperature	0 to 55°C		0 to 50°C *

**Note:** Specifications not listed above conform to CJ Series general specifications.

\* Refer to Operation Manual 3-3-5 *Mounting Precaution for CJ1W-NC413/NC433* for information on the ambient operating temperature of the CJ1W-NC413/433.

## Performance Specifications

Item	Model			
	CJ1W-NC113/133	CJ1W-NC213/233	CJ1W-NC413/433	
Applicable PLC models	CJ-series PLCs *1			
Unit type	Special I/O Unit			
I/O requirements	Words	5 words	10 words	20 words
Controlled driver	Pulse-train input-type Servo Drive or stepping motor driver NC113/213/413 models have open collector output. NC133/233/433 models have line driver output.			
Control	Control system	Open-loop control by pulse train output		
	Number of control axes	1 axis	2 axes	4 axes
Control unit	Pulse			
Positioning operations	Two types: memory operation and direct operation			
	Independent	1 axis	2 independent axes	4 independent axes
	Linear interpolation	None	2 axes max.	4 axes max.
	Speed control	1 axis	2 independent axes	4 independent axes
	Interrupt feeding	1 axis	2 independent axes	4 independent axes
Positions	Range	-1,073,741,823 to 1,073,741,823 pulses *2		
	Data items	100/axis		
Speeds	Range	1 pps to 500 kpps		
	Data items	100/axis		
Acceleration and deceleration times	Range	0 to 250 s, until maximum speed is reached.		
	Data items	9/axis for acceleration and deceleration each		
Functions and settings	Origin search	Origin proximity input signal: selectable (absent, N.O. or N.C. contact). Origin input signal: selectable (N.O. or N.C. contact) Origin compensation: -1,073,741,823 to 1,073,741,823 pulses Origin search speed: High-speed or proximity-speed can be set. Origin detection method: May be set to stop upon origin input signal after proximity input signal has turned ON, to stop upon origin input signal after proximity input signal has turned OFF, to stop upon origin input signal without using proximity input signal, or to stop upon origin input signal after limit input signal has turned OFF. N.O. = Normally open N.C. = Normally closed		
	Jogging	Jogging can be executed at a specified speed.		
	Dwell times	19/axis can be set from 0 to 9.99 s (unit: 0.01 s).		
	Acceleration/ deceleration curves	Trapezoidal or S-curve (Can be set separately for each axis.)		
	Zones	Zone Flag turns ON when present position is within a specified zone. Three zones can be set for each axis.		
Functions and settings	Software limits	Can be set within a range of -1,073,741,823 to 1,073,741,823 pulses.		
	Backlash compensation	0 to 9,999 pulses. Compensation speed can also be set.		
	Teaching	With a command from the PLC, the present position can be taken as the position data.		
	Deceleration stop	The STOP command causes positioning to decelerate to a stop according to the specified deceleration time.		
	Emergency stop	Pulse outputs are stopped by an external emergency stop command.		
	Present position preset	The PRESENT POSITION PRESET command can be used to change the present position to a specified value.		
	Override	When the override enabling command is executed during positioning, the target speed is changed by applying the override coefficient. Possible to set to a value from 1 to 999% (by an increment of 1%)		
	Data saving	1) Saving to flash memory. (Can be written 100,000 times.) 2) Reading from PLC area by data reading instruction. 3) Reading by Support Software and saving to personal computer hard disk or floppy disk.		
External I/O	Inputs	Prepare the following inputs for each axis: CW and CCW limit input signals, origin proximity input signal, origin input signal, emergency stop input signal, positioning completed signal, interrupt input signal		
	Outputs	Prepare the following outputs for each axis: Pulse outputs CW/CCW pulses, pulse outputs and direction outputs can be switched. Either error counter reset or origin-adjustment command outputs can be selected depending on the mode.		
Pulse output distribution period	1-axis operation: 4 ms Linear interpolation: 8 ms			
Response time	Refer to Operation manual <i>Appendix A Performance Characteristics</i> .			
Self-diagnostic function	Flash memory check, memory loss check, CPU bus check			
Error detection function	Overtravel, CPU error, software limit over, emergency stop			

\*1. The additional functions supported by unit version 2.0 can be used only when the PCU is installed with a CJ1-H or CJ1M CPU Unit (either CPU Unit Ver. 2.0 or Pre-Ver. 2.0 CPU Unit). These functions cannot be used if the PCU is installed with a CJ1 CPU Unit.  
For details on Unit versions, refer to *Unit Versions of CJ-series Position Control Units* on Operation manual page vi. (Final order entry date for CJ1M: The end of March, 2021)

\*2. When performing linear interpolation, the distances that can be moved will vary.

## External Interface

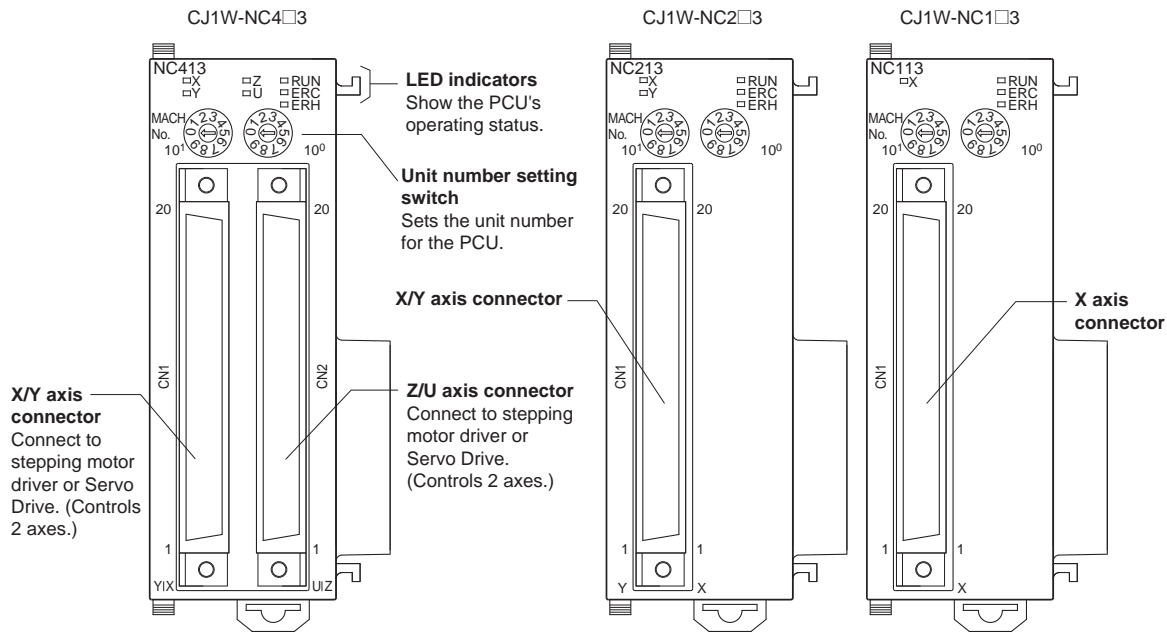

### LED Indicators

Name	Color	Status	Explanation
RUN	Green	Lit	Lit during normal operation.
		Not lit	Hardware error, or PLC notified of PCU error.
ERC	Red	Lit	An error has occurred.
		Not lit	No error has occurred.
ERH	Red	Lit	An error has occurred IN the CPU Unit.
		Not lit	No error has occurred at the CPU Unit.
X	Orange	Lit	Pulses are being output to the X axis (either forward or reverse).
		Flashing	An error has occurred, such as incorrect cable type for the X axis or faulty data.
		Not lit	None of the above has occurred.
Y	Orange	Lit	Pulses are being output to the Y axis (either forward or reverse).
		Flashing	An error has occurred, such as incorrect cable type for the Y axis or faulty data.
		Not lit	None of the above has occurred.
Z	Orange	Lit	Pulses are being output to the Z axis (either forward or reverse).
		Flashing	An error has occurred, such as incorrect cable type for the Z axis or faulty data.
		Not lit	None of the above has occurred.
U	Orange	Lit	Pulses are being output to the U axis (either forward or reverse).
		Flashing	An error has occurred, such as incorrect cable type for the U axis or faulty data.
		Not lit	None of the above has occurred.

- Note:**
- For the CJ1W-NC113/NC133, this applies only to the X axis; for the CJ1W-NC213/NC233, it applies only to the X and Y axes.
  - When not all of the axes are used for the CJ1W-NC213/NC233/ NC413/NC433, either connect the CW/CCW limit inputs for the unused axes to the input power supply and turn them ON or set the contact logic to N.O. Connect the emergency stop to the input common and turn it ON. If it is not connected, the ERC indicator will light. Operation will be normal, however, for all axes that are used.

## Functions Supported by Each Unit Version of Position Control Unit

Unit Version		Pre-Ver. 2.0	Ver. 2.0	Ver. 2.3
Internal system software version		1.0	2.0	2.3
CJ-series Position Control Units		CJ1W-NC113/133/213/233/413/433		
Functions	Changing the acceleration for a multiple start during relative movement or absolute movement in direct operation	Not supported	Supported	Supported
	Changing acceleration/deceleration time during jog operation	Not supported	Supported	Supported
	Setting acceleration/deceleration time for axis parameters until the target speed is reached	Not supported	Supported	Supported
	Easy backup function	Not supported	Supported	Supported
	Setting number of unused axes	Not supported	Not supported	Supported
	Setting CW/CCW pulse output direction	Not supported	Not supported	Supported
	Setting origin search pattern	Not supported	Not supported	Supported
	Position data setting when origin signal stops	Not supported	Not supported	Supported
	Setting jog operation	Not supported	Not supported	Supported
	Setting deviation counter reset output signal	Not supported	Not supported	Supported
Checking parameters and data at startup	Not supported	Not supported	Supported	
Support Software	CX-Position Ver. 1.0 or later	CX-Position Ver. 1.0 *1 CX-Position Ver. 2.0 or later	CX-Position Ver. 1.0 *1 CX-Position Ver. 2.0 *2 CX-Position Ver. 2.1 *2 CX-Position Ver. 2.2 or later	

**Note:** The Position Control Unit must be installed with CJ1-H or CJ1M CPU Unit to use the above functions supported for Position Control Unit Ver. 2.0. These functions cannot be used if the Position Control Unit is installed with a CJ1 CPU Unit. (Final order entry date for CJ1M: The end of March, 2021)

\*1. With CX-Position Ver. 1.0, new functions added to Position Control Units Ver. 2.0 or higher cannot be used.

\*2. With CX-Position Ver. 2.0 and CX-Position Ver. 2.1, new functions added to Position Control Units Ver. 2.3 or higher cannot be used.



# Dimensions

CJ1W-NC113/213/413  
NC133/233/433

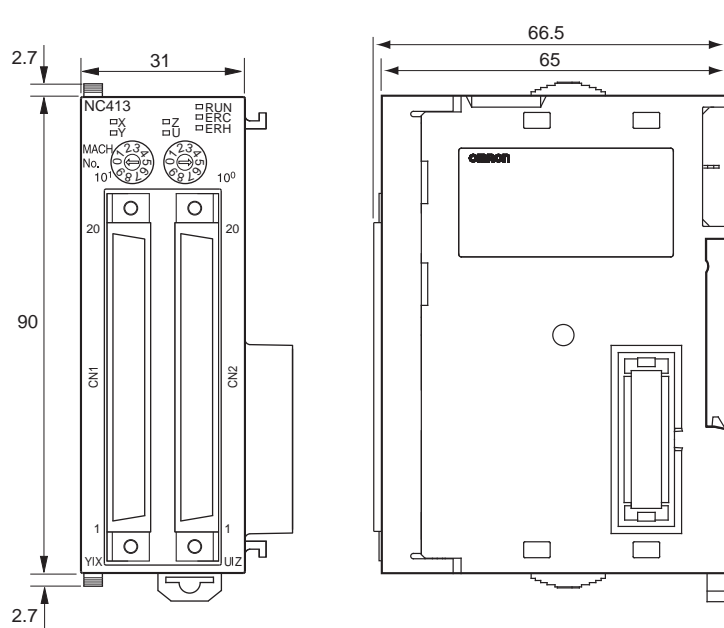

**Note:** The above diagram is for the CJ1W-NC413.

## Mounted Dimensions

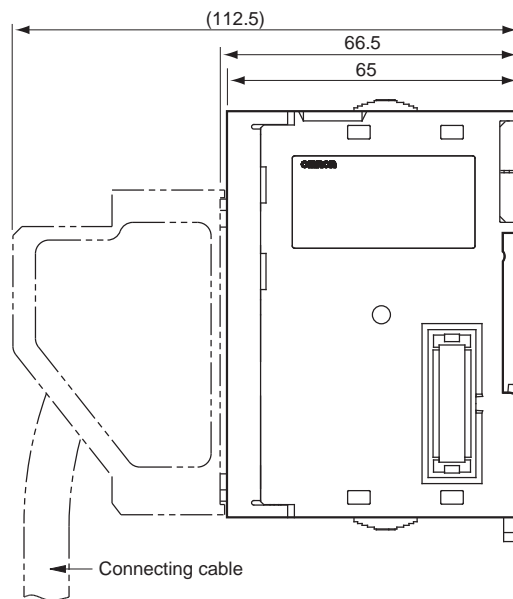



## CJ1W-SP001

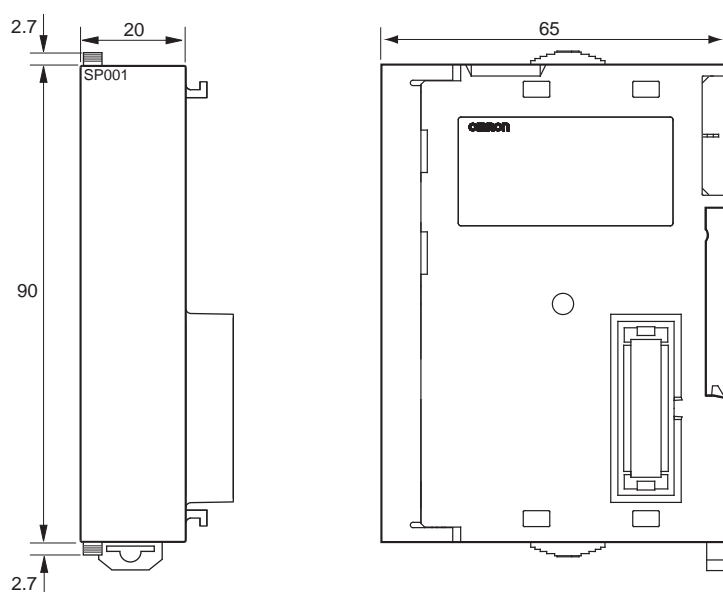

## Related Manuals

Manual number		Model	Name	Contents
English	Japanese			
W397	SBCE-315	CJ1W-NC113/133/213/233/413/433	Position Control Units Operation Manual	Provides information on operating and installing Position Control Units, including details on basic settings, memory operation, direct operation from CPU and other functions.
W433	SBCE-324	CXONE-AL□□D-V□	CX-Position Operation Manual	Provides an overview of CX-Position, its functions, and the system configuration, installation, and troubleshooting.