

SYSMAC CS-series Controller Link Units

CS1W-CLK

CSM_CS1W-CLK_DS_E_5_11

New Controller Link Units, Now with 4,000 Send Words

- The Controller Link is an FA network that can send and receive large amounts of data easily and at high speed. The Controller Link supports data links that enable sharing data between PLCs and computers and a message service that enables sending and receiving data whenever required.
- With Wired Controller Link Units, systems can be flexibly built by using Repeater Units to enable T-branches, long-distance wiring, and converting part of the network to optical cable.



CS1W-CLK23



CS1W-CLK13



CS1W-CLK53

Includes products no longer available to order.
See *Ordering Information* for details.

Features

- Large-capacity data links are easily achieved without programming simply by setting data link tables.
- Up to 20,000 *1 send/receive words can be set per node for Units (up to 62,000 words for Boards).
- Data links can be performed with up to 4,000 *2 words per node while ensuring data concurrency.
- User-set data link tables can be changed while data links are operating. *3
- Errors for the entire system can be monitored by using error diagnosis support software and a variety of status flags.
- With the token ring mode of Optical Ring Controller Link Units/Boards, duplex communications paths enable communications to continue normally even if the cable becomes disconnected.
- Detecting locations of disconnection greatly shortens time required for maintenance.
- Installing Controller Link Units in a CS1D system enables Duplex Communications Units to further enhance reliability. *4

*1. Supported for unit version 1.2 or later.

*2. CS1W-CLK□3 and 3G8F7-CLK□3 are supported.

*3. Supported for CS1W-CLK□3, 3G8F7-CLK□3, and models ending with "-V1" (CS1W-CLK12-V1 *5 and CS1W-CLK52-V1 *5 with lot numbers 0306□□_□□□ or later).

*4. Supported for CS1W-CLK13/CLK12-V1 *5/CLK53/CLK52-V1 *5 and CS1D Duplex and Simplex Systems.

*5. Discontinuation models in July 2012.

System Configuration

Wired Controller Link Units

Basic Wiring (Daisy Chain Connections)

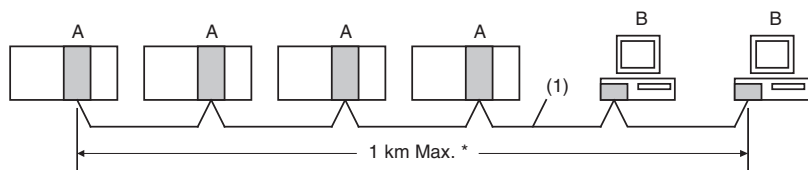

Long-distance Wiring

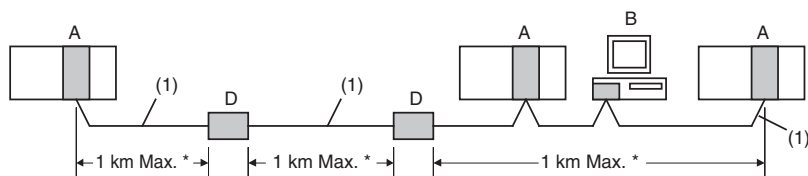

T-Branch Wiring and Partial Conversion to Optical Cable

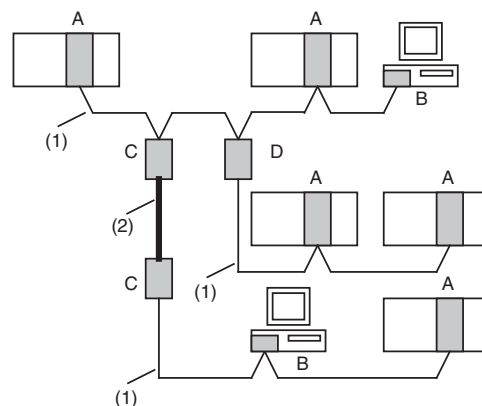

- A: Wired Controller Link Unit
- B: Wired Controller Link Support Board
- C: Wire-to-Optical Repeater Unit
- D: Wire-to-Wire Repeater Unit
- (1): Twisted-pair cable
- (2): Optical cable
- * At 500 kbits/s

Optical Controller Link Units

Token Ring Mode

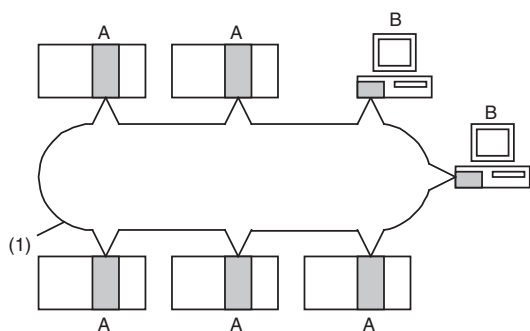

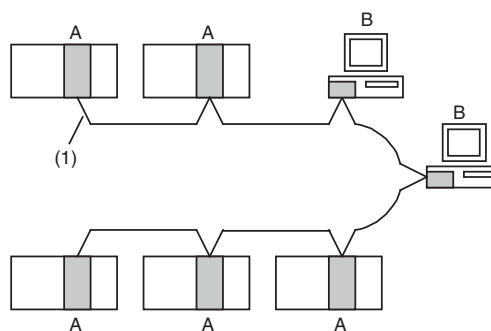

Token Bus Mode



- A: Optical Ring Controller Link Unit
- B: Optical Ring Controller Link Support Board
- (1): Optical cable

Ordering Information

Controller Link Units

Unit classification	Product name	Specifications				No. of unit numbers allocated	Current consumption (A)		Model	Standards
		Communications cable	Communications type	Duplex support	Max. Units mountable per CPU Unit		5 V DC	26 V DC		
CS1 CPU Bus Unit	Controller Link Unit 	Wired shielded twisted-pair cable *1	Data links and message service	No	8	1	0.33	–	CS1W-CLK23	UC1, N, L, CE
	Controller Link Unit 	Optical ring H-PCF cable *2		Yes. Unit duplexing and cable loop back are supported.	Non-duplex: 8, Duplex: 11 (6 Units comprising 3 sets of Duplex Units + 5 Non-duplex Units)	1	0.52	–	CS1W-CLK13	
	Controller Link Unit 	Optical ring GI cable *3				1	0.65	–	CS1W-CLK53	

*1. Use the following special cable for shielded, twisted-pair cable.

- ESVC0.5×2C-13262 (Bando Electric Wire : Japanese Company)
- ESNC0.5×2C-99-087B (JMACS Japan Co., Ltd. : Japanese Company)
- ESPC 1P×0.5mm² (Nagaoka Electric Wire Co.,Ltd. : Japanese Company)
- Li2Y-FCY2×0.56qmm (Kromberg & Schubert, Komtec Department : German Company)
- 1×2×AWG-20PE+Tr.CUSN+PVC (Draka Cables Industrial : Spanish Company)
- #9207 (Belden : US Company)

*2. When using a wire-to-optical (H-PCF) cable, use a H-PCF cable (for both Controller Link and SYSMAC LINK) or a H-PCF optical fiber cable with connector.

*3. When using a wire-to-optical (GI) cable, use a GI optical cable that matches the specifications.

Accessories

The Optical Fiber Cable Bracket is included in CS1W-CLK13 and CS1W-CLK53.

Controller Link Support Boards (Product no longer available to order)

Product name	Specifications		Accessories	Model	Standards	
	Communications cable	Communications type				
Controller Link Support Board for PCI Bus 	Wired shielded twisted-pair cable	Data links and message service	<ul style="list-style-type: none"> • CD-ROM × 1 * • INSTALLATION GUIDE (W467) × 1 • Communications connector × 1 	3G8F7-CLK23-E	CE, KC	
	H-PCF optical model			<ul style="list-style-type: none"> • CD-ROM × 1 * • INSTALLATION GUIDE (W467) × 1 • Optical Fiber Cable Bracket × 1 • Power supply connector × 1 	3G8F7-CLK13-E	CE
	GI optical model				3G8F7-CLK53-E	

* The CD-ROM contains the following software.

- Controller Link (PCI) Driver
- FinsGateway Version 2003 (PCI-CLK Edition)
- FinsGateway Version 3 (PCI-CLK Edition)
- Setup Diagnostic Utility
- C Library

Repeater Units

Name	Specifications	Model	Standards
Controller Link Repeater Unit 	Wire-to-Wire Model	CS1W-RPT01	UC1, CE
	Wire-to-Optical (H-PCF) Model (See note 1.)	CS1W-RPT02	
	Wire-to-Optical (GI) Model (See note 2.)	CS1W-RPT03	

Using Repeater Units enables T-branches and long-distance wiring for Wired Controller Link networks, 62-node configurations, and converting part of the network to optical cable.

Note: 1. When using wire-to-optical (H-PCF) cable, use a H-PCF cable (for both Controller Link and SYSMAC LINK) or a H-PCF optical fiber cable with connector.

2. When using wire-to-optical (GI) cable, use a GI optical cable (for Controller Link).

Relay Terminal Block

Name	Specifications	Model	Standards
Relay Terminal Blocks for Wired Controller Link Units 	Used for Wired Controller Link Units (set of 5)	CJ1W-TB101	–

Controller Link Units can be replaced without stopping the communications of the entire network if a Relay Terminal Block is installed in advance on the Unit in a Wired Controller Link network. Relay Terminal Blocks cannot be used on Controller Link Support Boards.



Duplex Optical Fiber Cable (H-PCF Cable)

Name	Application	Specifications	Model	Standards
Duplex Optical Fiber Cable	CS1W-CLK13 or CS1W-CLK12-V1 * in a CS1D system	H-PCF cable for connecting Duplex Controller Link Units Cable length: 50 cm	CS1D-CN051	–

This cable is used to connect Units in active mode (ACT) and standby mode (STB) in a CS1D Duplex System.

* Discontinuation models in July 2012.

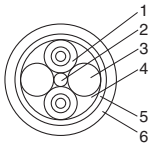

H-PCF Cables and Optical Connectors

Name	Application/construction	Specifications	Model	Standards	
Optical Fiber Cables	 <p>1. Optical fiber single-core cord 2. Tension member (plastic-sheathed wire) 3. Filler (plastic) 4. Filler surrounding signal wires (plastic, yarn, or fiber) 5. Holding tape (plastic) 6. Heat-resistant PV sheath</p>	Two-core optical cable with tension member	Black 10 m	S3200-HCCB101	-
			Black 50 m	S3200-HCCB501	
			Black 100 m	S3200-HCCB102	
			Black 500 m	S3200-HCCB502	
			Black 1000 m	S3200-HCCB103	
			Orange 10 m	S3200-HCCO101 *1	
			Orange 50 m	S3200-HCCO501 *1	
			Orange 100 m	S3200-HCCO102 *1	
			Orange 500 m	S3200-HCCO502 *1	
Orange 1000 m	S3200-HCCO103 *1				
Optical Connectors (Crimp-cut)	 <p>Controller Link: CS1W-CLK13 CS1W-CLK12-V1 *1 3G8F7-CLK13-E *1 3G8F7-CLK12-EV1 *1 CS1W-RPT02 CS1W-SLK11</p> <p>SYSMAC LINK: 3G8F7-SLK11-E *1 C200HW-SLK13/14 *1</p>	Half lock	S3200-COCF2571	-	
	 <p>Controller Link: CS1W-CLK13 CS1W-CLK12-V1 *1 3G8F7-CLK13-E *1 3G8F7-CLK12-EV1 *1 CS1W-RPT02 CS1W-SLK11</p> <p>SYSMAC LINK: 3G8F7-SLK11-E *1</p>	Full lock	S3200-COCF2071 *2		

*1. Discontinuation models.

*2. Full-lock Optical Connectors (Crimp-cut) (S3200-COCF2071) cannot be used with the CS1W-SLK11. Use a Half-lock Cable (S3200-COCF2571) or a H-PCF Optical Fiber Cable with Connector (S3200-CN□□□-□□-□□).

H-PCF Optical Fiber Cables with Connectors (Black Composite Cables with Two-Optical Lines and Two Power Supply Lines)

Application	Appearance	Model	Standards
Controller Link, SYSMAC LINK		S3200-CN□□□-20-20	-
		S3200-CN□□□-20-25	
		S3200-CN□□□-25-25	

Optical connectors for H-PCF Optical Cables with Connectors are adhesive polished.

Cable Length

The following cable lengths are available: 2 m, 5 m, 15 m, and 20 m. For lengths of 21 m or more, contact your OMRON sales representative.

Model Numbers

(1) 2 m, 5 m, 10 m, 15 m, or 20 m

(2) 21 m or longer

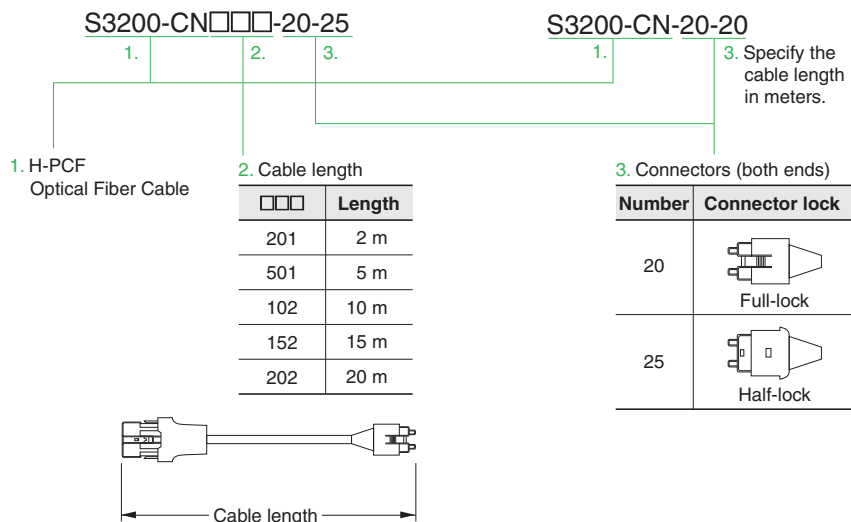

Optical Connector Assembly Tool

Name	Applicable Unit	Model	Manufacturer	Standards
Optical Fiber Assembly Tool (See note.)	This tool is used on site for mounting crimp-cut connectors and hard plastic-clad silica optical fiber for optical transmission systems of SYSMAC C-series SYSBUS, SYSMAC LINK, and Controller Link.	CAK-0057	Sumitomo Electric Industries, Ltd.	–

Note: There is a risk of quality problems when using cables assembled by typical users, so we recommend purchasing cables with preattached connectors or having a qualified technician assemble the cables.

GI Optical Cables

A qualified technician must select, assemble, and install GI Optical Fiber Cable, so always let an optical cable specialist handle the GI cable.

Usable Optical Cables and Optical Connectors

- Optical fiber types: Graded, indexed, multi-mode, all quartz glass, fiber (GI-type AGF cable)
- Optical fiber construction (core diameter/clad diameter): 62.5/125 μm or 50/125 μm
- Optical fiber optical characteristics of optical fiber: Refer to the tables.
- Optical connector: ST connector (IEC-874-10)

• 50/125-μm AGF Cable

Item	Minimum	Standard	Maximum	Conditions
Numerical aperture (N.A)	–	0.21	–	–
Transmission loss (dB)	–	–	3.0Lf	0.5 km ≤ Lf
			3.0Lf+0.2	0.2 km ≤ Lf ≤ 0.5 km
			3.0Lf+0.4	Lf ≤ 0.2 km
Connection loss (dB)	–	–	1.0	λ = 0.8 μm, one location
Transmission bandwidth (MHz-km)	500	–	–	λ = 0.85 μm (LD)

Lf is fiber length in km, Ta is ambient temperature, and λ is the peak wavelength of the test light source.

• 62.5/125-μm AGF Cable

Item	Minimum	Standard	Maximum	Conditions
Numerical aperture (N.A)	–	0.28	–	–
Transmission loss (dB)	–	–	3.5Lf	0.5 km ≤ Lf
			3.5Lf+0.2	0.2 km ≤ Lf ≤ 0.5 km
			3.5Lf+0.4	Lf ≤ 0.2 km
Connection loss (dB)	–	–	1.0	λ = 0.8 μm, one location
Transmission bandwidth (MHz-km)	200	–	–	λ = 0.85 μm (LD)

Lf is fiber length in km, Ta is ambient temperature, and λ is the peak wavelength of the test light source.

International Standards

- The standards indicated in the Standards column are those current for UL, CSA, cULus, cUL, NK, and Lloyd standards and EC Directives as of the end of July 2007. The standards are abbreviated as follows: U: UL, U1: UL (Class I Division 2 Products for Hazardous Locations), C: CSA, UC: cULus, UC1: cULus (Class I Division 2 Products for Hazardous Locations), CU: cUL, N: NK, L: Lloyd, CE: EC Directives, and KC: KC Registration.
- Ask your OMRON representative for the conditions under which the standards were met.

Mountable Racks

Model		CS1 System				CS1D System						
		CPU Rack		Expansion Backplane (including Long-distance Expansion Rack)		SYSBUS Remote I/O Slave Rack	C200HX/HG/HE Expansion I/O Rack	CPU Rack			Expansion Backplane	
		CS1W-BC		CS1W-BI				CS1D-BC			CS1D-BI	
		□□3	□□2	□□3	□□2			052	042D	082S	092	082D
CS1W-CLK23 CS1W-CLK13 CS1W-CLK53	Unit version 2.0	8 Units (per CPU Unit)				Not supported	Not supported	8 Units (per CPU Unit)				
CS1W-CLK21-V1 CS1W-CLK12-V1 *1 CS1W-CLK52-V1	Unit version 1.2	8 Units (per CPU Unit)						8 Units *2 (per CPU Unit)				
CS1W-CLK21-V1 CS1W-CLK12-V1 *1 CS1W-CLK52-V1	Pre-Ver. 1.2	4 Units (per CPU Unit)						4 Units *3 (per CPU Unit)				

*1. Discontinuation models in July 2012.

*2. Optical Ring Controller Link Units support 11 Units maximum for duplex (6 Units comprising 3 sets of Duplex Units + 5 Non-duplex Units).

*3. Optical Ring Controller Link Units support 7 Units maximum for duplex (6 Units comprising 3 sets of Duplex Units + 1 Non-duplex Unit).

Communications Specifications

Items	Specifications		
Model	CS1W-CLK23 3G8F7-CLK23-E *1 CS1W-CLK21-V1 *1 3G8F7-CLK21-EV1 *1	CS1W-CLK13 3G8F7-CLK13-E *1 CS1W-CLK12-V1 *1 3G8F7-CLK12-EV1 *1	CS1W-CLK53 3G8F7-CLK53-E *1 CS1W-CLK52-V1 *1 3G8F7-CLK52-EV1 *1
Type	Wired (shielded twisted-pair cable)	Optical Ring (H-PCF cable)	Optical Ring (GI cable)
Communications method	N:N token-bus method	N:N token-ring method (token-ring mode) N:N token-bus method (token-bus mode)	
Code	Manchester code		
Modulation	Baseband code		
Synchronization	Flag synchronization (conforms to HDLC frames)		
Transmission path format	Multidrop method (bus type)	<ul style="list-style-type: none"> • Ring method (token-ring mode) • Daisy-chain method (token-ring mode) 	
Transmission speed	The following are the maximum transmission distances depending on the transmission speed.	2 Mbits/s	
Maximum transmission distance	2 Mbits/s: 500 m 1 Mbits/s: 800 m 500 kbits/s: 1 km	20 km	30 km
Maximum distance between nodes	Not specified. (Maximum transmission distance must be satisfied for the entire system.)	Crimp-cut: 800 m Adhesive polishing: 1 km *2	62.5/125 μm: 2 km 50/125 μm: 1 km
Medium	Specified shielded twist-pair cable Two signal wires, one shield	H-PCF cable (two-core optical cable)	GI cable (two-core optical cable: 62.5/125 μm, 50/125 μm)
Node connection method	PLC: Connection to terminal block Computer: Connection using special (supplied) connector	Connection using special connector (full-lock connector or half-lock connector)	Connection using ST connector
Maximum number of nodes	32 or 62 nodes *3 *4	62 *5	
Applicable Programming Devices	CX-Integrator in CX-One, CX-Net in CX-Programmer *4, and Programming Console		
Communications functions	Data links and message service		
Number of data link words	Send words per node: 4,000 words max. (CS1W-CLK□3), 1,000 words max. (All other Units) Number of send/receive words per node: 12,000 words max. (Pre-Ver. 1.2) 20,000 words max. (unit Ver. 1.2 or later) Total number of send words per network: 62,000 words max.		
Data link areas	PLC: Bit areas (CIO Area, Work Area, Link Area *6), Data Memory (DM), Extended DM Area (EM) Computer: FinsGateway event memory		
Message length	2,012 bytes max. (including the header)		
RAS functions	<ul style="list-style-type: none"> • Polling node backup function • Self-diagnosis function (hardware checking at startup) • Echoback test and broadcast test (using the FINS command) • Watchdog timer • Error log function 	<ul style="list-style-type: none"> • Polling node backup function • Self-diagnosis function (hardware checking at startup) • Echoback test and broadcast test (using the FINS command) • Watchdog timer • Error log function • Node bypass function • Transmission path duplication (for ring method in token-ring mode only) • Disconnect detection and notification (token-ring mode only) • Node connection configuration data reading (for ring method in token-ring mode only) • Duplex operation of Communications Units *7 	
Error control	Manchester code check CRC check (CCITT $X^{16}+X^{12}+X^5+1$)		

*1. Product no longer available to order.

*2. The maximum distance between nodes depends on the processing method for connectors and cables.

*3. With wired models, the maximum number of nodes is 32 if Repeater Units are not used. A Repeater Unit is required when building a network with more than 32 nodes. If a Repeater Unit is used, be sure to use only the following Controller Link Units or Boards and set the Wired Network 62 Node Enable Bit in the DM Parameter Area software switches at all nodes.

CS1W-CLK23/CLK21-V1 *1

CJ1W-CLK23/CLK21-V1 *1

3G8F7-CLK23-E/CLK21-EV1 *1

*4. CX-Net in CX-Programmer version 3.1 or earlier can be used only in a system with a maximum of 32 nodes (node address 1 to 32). If a system is to be used with a maximum of 62 nodes (node addresses 1 to 62), use CX-Net in CX-Programmer version 3.2 or higher or the CX-Integrator.

*5. If duplex Controller Link Units are used, the effective maximum number of nodes will be 62 (i.e., the maximum number of nodes in standby mode (STB)).

*6. CS-series PLCs do not have a Link Area, but LR000 to LR199 are automatically converted CIO 1000 to CIO 1199.

*7. Only when a CS1W-CLK13/12-V1 *1/53/52-V1 *1 installed in a CS1D system is used in token ring mode.

Individual Specifications

Controller Link Units

Item		Specifications		
Model		CS1W-CLK23 CS1W-CLK21-V1 *	CS1W-CLK13 CS1W-CLK12-V1 *	CS1W-CLK53 CS1W-CLK52-V *
Supported PLC		All CS-series CPU Units		
Number of mountable Units		Unit version 1.2 or later: 8 Units max., Pre-Ver. 1.2: 4 Units max.		
Installation site		Install onto a CPU Backplane or CS-series Expansion Backplane (classified as a CPU Bus Unit).		
Storage location for network parameters and manually set data tables		CPU Bus Unit Area (in the CPU Unit parameter area)		
Storage location for routing tables		CPU Unit parameter area		
Weight		220 g	300 g (excluding mounting bracket)	300 g (excluding mounting bracket)
Current consumption	5 V in PLC	0.33 A	0.52 A	0.65 A
	26 V in PLC	–	–	–
	External 24 V	–	0.20 A	0.26 A

* Discontinuation models in July 2012.

Controller Link Support Boards (for PCI Bus)

Item		Specifications		
Models		3G8F7-CLK23-E	3G8F7-CLK13-E	3G8F7-CLK53-E
Applicable computers		IBM PC/AT or compatible <ul style="list-style-type: none"> • CPU: Intel Celeron 400 MHz or better • Main memory: 128 MB minimum • One or more PCI bus slots (PCI bus revision 2.0 or higher, power supply: 5 V) • Available hard disk space: 70 MB min. • CD-ROM drive: One required for installation • Display: VGA (640 × 480 (pixels) min.) (Other conditions conform to the OS.)		
Compatible OS		<ul style="list-style-type: none"> • FinsGateway Version 2003 *1 <ul style="list-style-type: none"> Windows 10 (32bit) Windows 8 (32bit) Windows 7 (32bit) Professional Windows 7 (32bit) Home Premium Windows Vista Business Windows Vista Home Premium • FinsGateway Version 3 *2 <ul style="list-style-type: none"> Windows XP Professional Windows XP Home Edition Windows 2000 Professional Windows NT 4.0 (Service Pack 3 or higher) Windows ME Windows 98SE 		
Weight		104 g	120 g (excluding mounting bracket)	124 g (excluding mounting bracket)
Current consumption	5 V in PLC	0.35 A	0.54 A	0.60 A
	External 24 V	–	0.35 A	0.35 A

Note: Controller Link Support Boards (for PCI Bus) is no longer available to order.

*1. Install the software from CD Ver. 3.12 or higher if the operating system is Windows 10 or 8 (32bit).

*2. Install FinsGateway version 3 if the operating system is Windows NT 4.0 (Service pack 3 or higher), Windows ME, or Windows 98SE. In that case, however, the new functions of Controller Link Support Boards for the PCI Bus cannot be used (i.e., automatic data link creation with 1:N allocation, changing data link tables with active data links, 62-node setting for wired models, and maximum of 4000 send words).

Repeater Units

Item		Specifications		
Model		CS1W-RPT01	CS1W-RPT02	CS1W-RPT03
Supported Units and Boards		All wired Controller Link Units and Boards Note: If a maximum of 62 nodes is used, models that support 62 nodes must be used.		
Transmission path		Wire-to-wire	Wire-to-optical (H-PCF)	Wire-to-optical (GI)
Transmission path format		Multi-drop Tree	1:1	1:1
Installation		Repeater Units are not mounted to the PLC. They are mounted separately with screws or on a DIN Track.		
Weight		130 g	130 g (excluding mounting bracket)	130 g (excluding mounting bracket)
Allowable power supply voltage range		20.4 to 26.4 VDC (24 VDC –15 V to +10%)		
Current consumption		0.06 A at 24 VDC	0.06 A at 24 VDC	0.07 A at 24 VDC
Inrush current		2.5 A max. (24 VDC with rise time of 5 ms)		

Repeater Units are used to expand the Controller Link network for wired models. For Wired-to-optical Repeater Units, always use a set of two (1:1). Optical Ring Controller Link Units and Boards cannot be connected to the optical cable section between Repeater Units.

External Interfac

CS1W-CLK23/CS1W-CLK21-V1 *

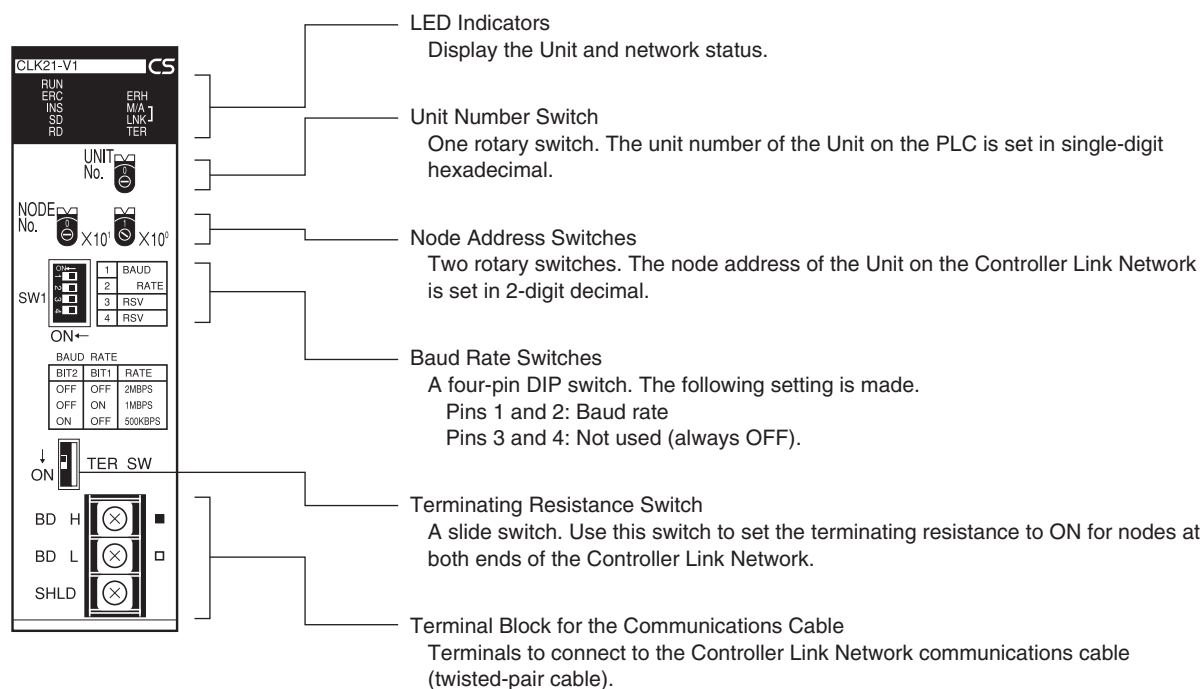

* Discontinuation models in July 2012.

Definition of Terminal Block Pin Names for Communications Cables

Marking	Notation	Signal name	Line color
■	BD H	Communications data, high	Black
□	BD L	Communication data, low	White
None	SHLD	Shield	None

Crimp Terminals

Use crimp terminals (M3) having the dimensions shown below.



CS1W-CLK13/CS1W-CLK12-V1 *

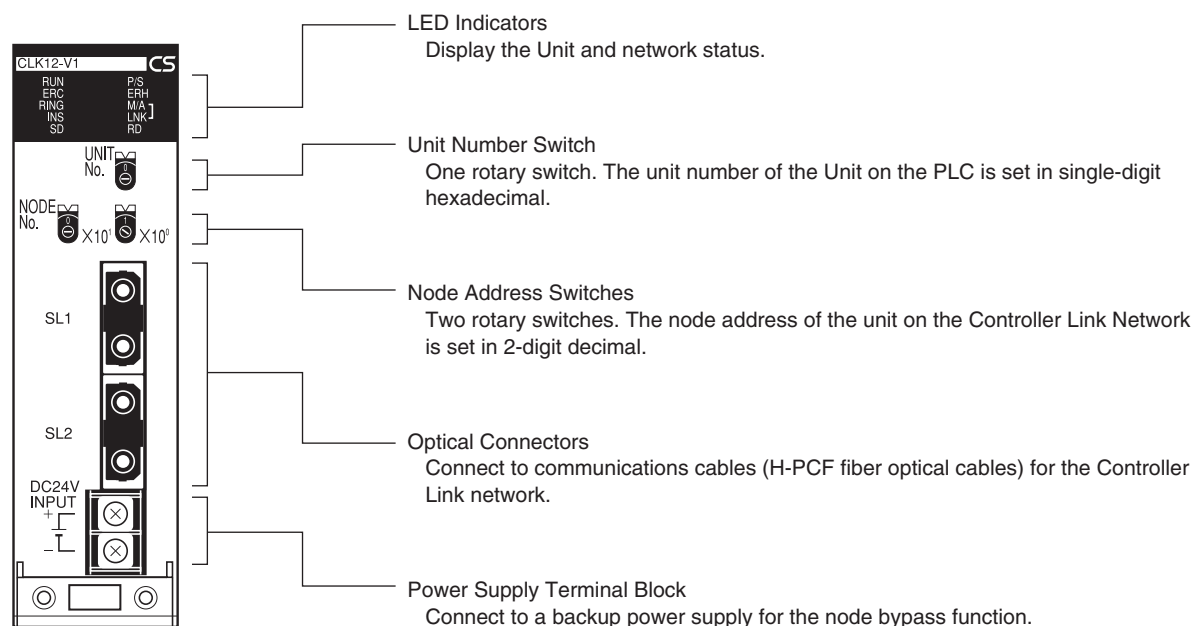

* Discontinuation models in July 2012.

Crimp Terminals

Use crimp terminals (M3) having the dimensions shown below.



CS1W-CLK53/CS1W-CLK52-V1 *

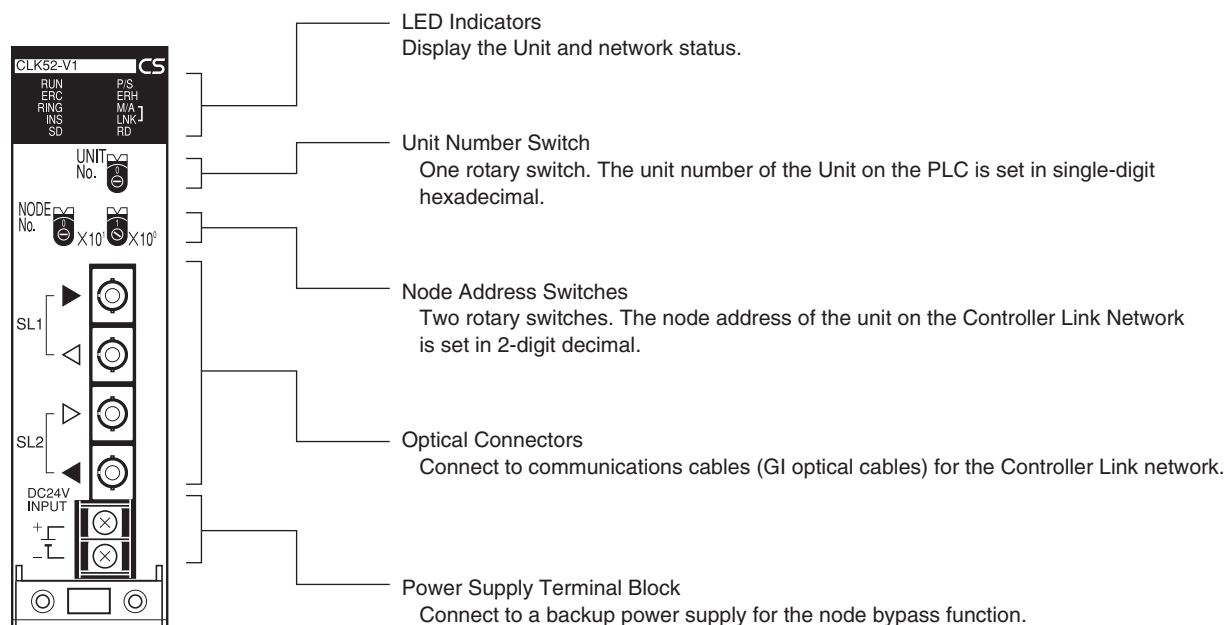

* Discontinuation models in July 2012.

Crimp Terminals

Use crimp terminals (M3) having the dimensions shown below.



Usage Precautions

- Old models and new models can be used mixed on the same network. In that case, however, build the system using the specifications for the old models. The data link send/receive words can be separately set to their maximums when new and old models are mixed.
- Repeater Units can be used to expand a Wired Controller Link Network. For Wired-to-optical Repeater Units, always use a set of two (1:1). Optical Ring Controller Link Units and Boards cannot be connected to the optical cable section between Repeater Units.
- Connect Repeater Units so that there are no more than two stages between any two nodes. One set of two Wire-to-Optical Repeater Units is counted as one stage.

Dimensions

CS1W-CLK23/CS1W-CLK21-V1 *

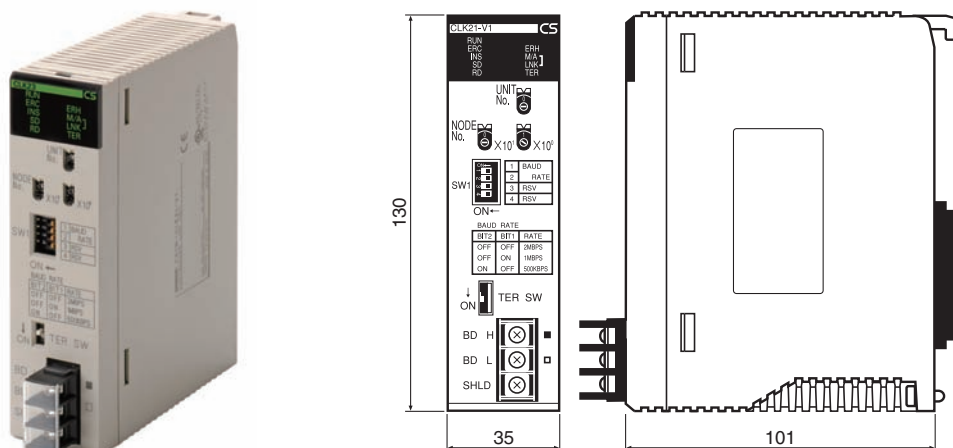

CS1W-CLK13/CS1W-CLK12-V1 *

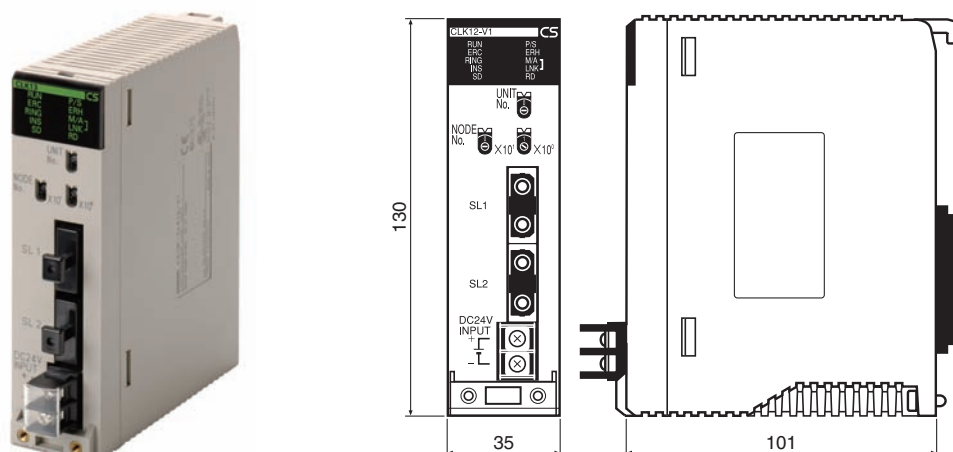

CS1W-CLK53/CS1W-CLK52-V1 *

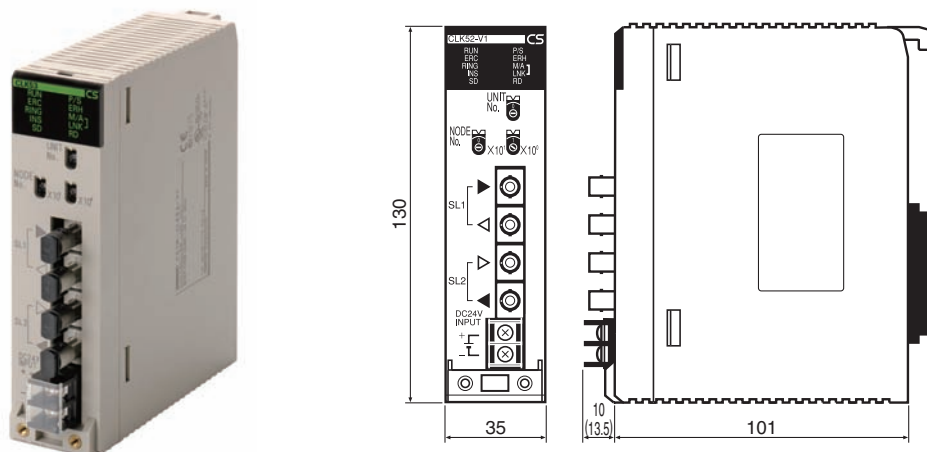

Note: The dimensions in parentheses are for the CS1W-CLK53 (including the terminal cover).
 * Discontinuation models in July 2012.

Related Manuals

Cat. No.	Models	Name	Application	Description
W309	CS1W-CLK23 CS1W-CLK21-V1 CJ1W-CLK23 CJ1W-CLK21-V1 C200HW-CLK21 CVM1-CLK21 CQM1H-CLK21 CS1W-RPT01/02/03	Controller Link Units Operation Manual	Used when information regarding operating procedures for Wired Controller Link Units is needed.	Describes operating procedures for Controller Link Units. Controller Link Units can connect to Wired Controller Link Units.
W422	3G8F7-CLK12-V1 3G8F7-CLK52-V1 3G8F7-CLK21-V1	Controller Link Support Boards for PCI Bus Installation Guide (3G8F7-CLK12/21/52-V1)	Used when information regarding setup procedures for Controller Link Support Boards for PCI bus connections is needed.	Describes the setup method for the Controller Link Support Boards for PCI bus connections.
W467	3G8F7-CLK13 3G8F7-CLK12-V1 3G8F7-CLK53 3G8F7-CLK52-V1 3G8F7-CLK23 3G8F7-CLK21-V1	Controller Link Support Board for PCI Bus Installation Guide (3G8F7-CLK13/12-V1/53/52-V1/23/21-V1)	Used when information regarding setup procedures for Controller Link Support Boards for PCI bus connections is needed.	Describes the setup method for the Controller Link Support Boards for PCI bus connections.
W383	3G8F7-CLK13 3G8F7-CLK12-V1 3G8F7-CLK53 3G8F7-CLK52-V1 3G8F7-CLK23 3G8F7-CLK21-V1	Controller Link Support Boards for PCI Bus Operation Manual	Used when information regarding setup procedures for Controller Link Support Boards for PCI bus connections is needed.	Describes the setup method for the Controller Link Support Boards for PCI bus connections.
W370	CS1W-CLK13 CS1W-CLK12-V1 CVM1-CLK12 CS1W-CLK53 CS1W-CLK52-V1 CVM1-CLK52	Optical Ring Controller Link Units Operation Manual	Used when information regarding operating procedures for Optical Ring Model Controller Link Units is needed.	Describes the operating procedures for Controller Link Units. Controller Link Units can connect to Controller Link Networks (Optical Ring System for H-PCF Cable, or GI Cable). Refer to this manual for information regarding the discontinued CS1W-CLK11 Optical Bus Controller Link Unit.
W464	CXONE-AL□□D-V□	CX-Integrator Operation Manual	Used when network setup or network monitoring needs to be performed.	Describes the operating procedures for the CX-Integrator.
W463	CXONE-AL□□D-V□	CX-One FA Integrated Tool Package Setup Manual	Used when installing software from the CX-One.	Provides an overview of the FA Integration Tool Package CX-One, and describes the CX-One installation procedures.