

The Next-generation Sensor Networking Units That Revolutionize the Workplace from Introduction and Startup though Operation



- Low initial cost achieved by distributed placement with the Sensor Communications Unit and Distributed Sensor Units (patent pending).
- Programless transmission of ON/OFF signals and detected quantities to host PLC.
- Reading and writing threshold values and function settings, tuning, and other operations are possible.
- Wire saving: simply connect the communications cable and power cable, and slide the Amplifier Units from the side.



⚠ Refer to *Safety Precautions* on pages 3 to 6.

For the most recent information on models that have been certified for safety standards, refer to your OMRON website.

System Configuration

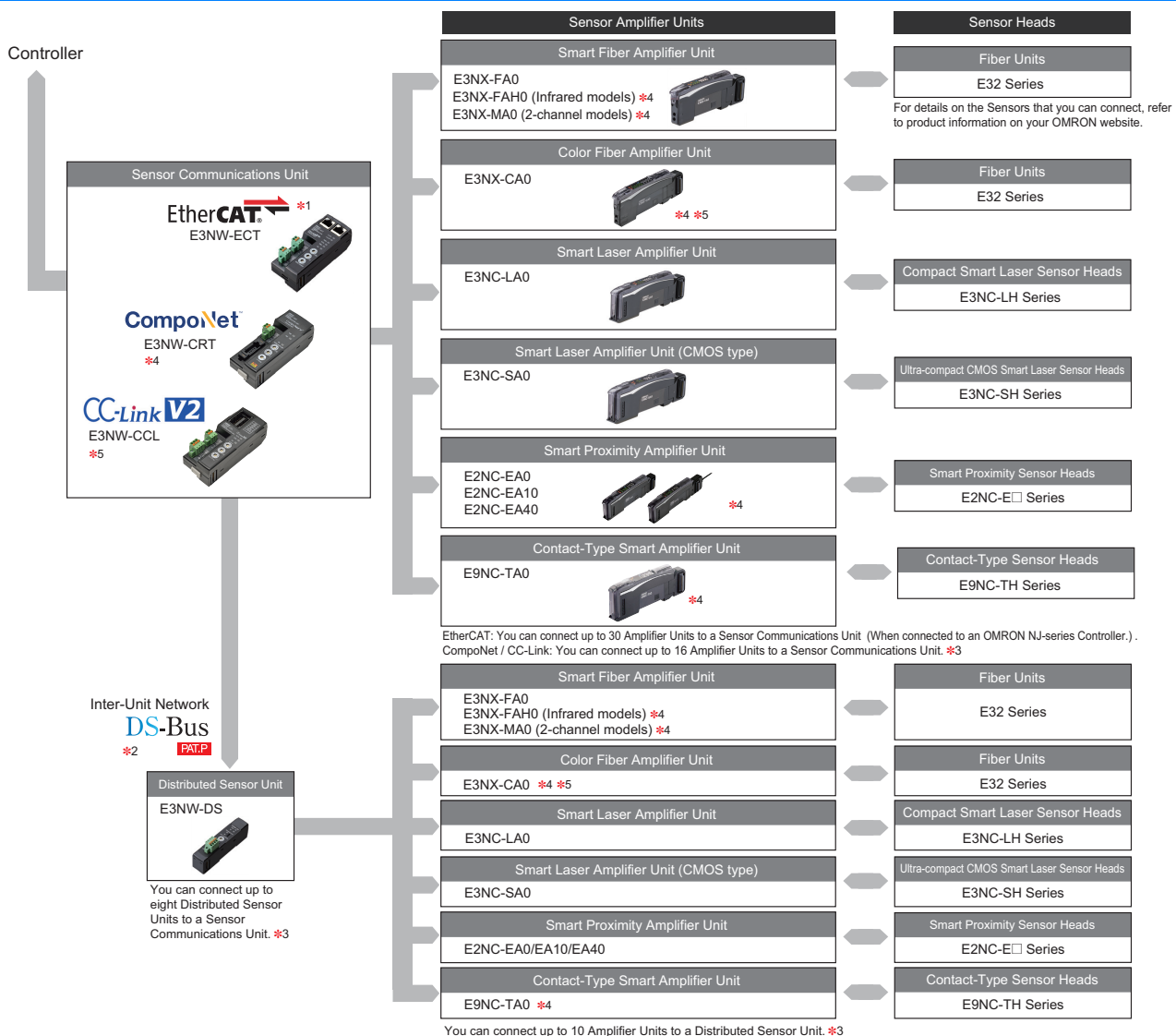

*1. EtherCAT® is a registered trademark and patented technology, licensed by Beckhoff Automation GmbH, Germany.
CompoNet is a registered trademark of the ODVA.
CC-Link is a registered trademark of Mitsubishi Electric Corporation. The trademark is managed by the CC-Link Partner Association.

*2. The DS-Bus is an OMRON inter-unit network communications protocol that connects the Sensor Communications Unit and Distributed Sensor Units.



*3. The total number of Sensors that can be connected to the Sensor Communications Unit and Distributed Sensor Units are as follows.
For EtherCAT: up to 30 (when connected to an OMRON NJ-series Controller, however, up to 16 for E2NC-EA10/EA40)
For CompoNet / CC-Link: up to 16

*4. The E3NW-CRT cannot be connected to E3NX-FAH0, E3NX-MA0, E3NC-CA0 and E9NC-TA0.

*5. The E3NW-CCL and E3NX-CA0 cannot be connected.

Ordering Information

Sensor Communications Unit (Dimensions → pages 8 and 9)

Communications method and Unit appearance	Model
EtherCAT 	E3NW-ECT
CompoNet 	E3NW-CRT
CC-Link 	E3NW-CCL

Distributed Sensor Unit (Dimensions → page 9)

Appearance	Model
	E3NW-DS

Note: Use the following DS-Bus communication cable (recommended) when connecting a sensor communications unit and a distributed sensor unit.

Item	Manufacturer	Model
Communication cable	BANDO DENSEN Co., Ltd.	ESVC 0.5X2C, black

Connectable Sensor Amplifier Units

Type	Model
Smart Fiber Amplifier Unit	E3NX-FA0
Smart Fiber Amplifier Unit (Infrared models)	E3NX-FAH0 *1
Smart Fiber Amplifier Unit (2-channel models)	E3NX-MA0 *1
Color Fiber Amplifier Unit	E3NX-CA0 *1 *2
Smart Laser Amplifier Unit	E3NC-LA0
Smart Laser Amplifier Unit (CMOS type)	E3NC-SA0
Smart Proximity Amplifier Unit	E2NC-EA0 *1
	E2NC-EA10 *1
	E2NC-EA40 *1
Contact-Type Smart Amplifier Unit	E9NC-TA0 *1

*1. E3NW-CRT Sensor Communications Units (CompoNet) cannot be used.

*2. E3NW-CCL Sensor Communications Units (CC-Link) cannot be used.

Connector cover for Sensor Communications Unit and Distributed Sensor Unit (provided)

Order a Cover when required, e.g., if you lose the covers.

Model
E39-G27

Ratings and Specifications

Sensor Communications Unit EtherCAT

Item	Model	E3NW-ECT
Connectable Sensor Amplifier Units		N-Smart Smart Fiber Amplifier Unit: E3NX-FA0 Smart Fiber Amplifier Unit (Infrared models): E3NX-FAH0 Smart Fiber Amplifier Unit (2-channel models): E3NX-MA0 Color Fiber Amplifier Unit: E3NX-CA0 * ¹ Smart Laser Amplifier Unit: E3NC-LA0 Smart Laser Amplifier Unit (CMOS type): E3NC-SA0 Smart Proximity Amplifier Unit: E2NC-EA0 E2NC-EA10 E2NC-EA40 Contact-Type Smart Amplifier Unit: E9NC-TA0 * ²
Power supply voltage		24 VDC (20.4 to 26.4 V)
Power and current consumption		2.4 W max. (Not including the power supplied to Sensors.), 100 mA max. (Not including the current supplied to Sensors.)
Indicators		L/A IN indicator (green), L/A OUT indicator (green), PWR indicator (green), RUN indicator (green), ERROR indicator (red), and SS (Sensor Status) indicator (green/red)
Vibration resistance (destruction)		10 to 60 Hz with a 0.7-mm double amplitude, 50 m/s ² at 60 to 150 Hz, for 1.5 hours each in X, Y, and Z directions
Shock resistance (destruction)		150 m/s ² for 3 times each in X, Y, and Z directions
Ambient temperature range		Operating: 0 to 55°C; * ³ Storage: -30 to 70°C (with no icing or condensation)
Ambient humidity range		Operating and storage: 25% to 85% (with no condensation)
Maximum connectable Sensors * ³ * ⁴		30 (when connected to an OMRON NJ-series Controller, 16 for E2NC-EA10/EA40)
Maximum connectable Distributed Sensor Units		8
Insulation resistance		20 MΩ min. (at 500 VDC)
Dielectric strength		500 VAC at 50/60 Hz for 1 min
Mounting method		35-mm DIN track - mounting
Weight (packed state/Unit only)		Approx. 185 g/approx. 95 g
Materials		Polycarbonate
Accessories		Power supply connector, communications connector for E3NW-DS connection, DIN Track End Plates (2 pieces), and instruction manual

*1. The E3NX-CA0 is supported for firmware version 1.06 or higher (Sensor Communications Units manufactured in June 2016 or later).

*2. The E9NC-TA0 is supported for firmware version 1.03 or higher (Sensor Communications Units manufactured in July 2014 or later).

*3. Temperature Limitations Based on Number of Connected Amplifier Units:

Groups of 1 or 2 Amplifier Units: 0 to 55°C, Groups of 3 to 10 Amplifier Units: 0 to 50°C, Groups of 11 to 16 Amplifier Units: 0 to 45°C, Groups of 17 to 30 Amplifier Units: 0 to 40°C

*4. This is the total number of Sensors that can be connected to the Sensor Communications Unit and Distributed Sensor Units.

Communications Specifications

Item	Specifications
Communications protocol	Dedicated protocol for EtherCAT
Modulation	Baseband method
Baud rate	100 Mbps
Physical layer	100BASE-TX (IEEE 802.3u)
Topology	Daisy chain
Communications media	STP category 5 or higher
Communications distance	Distance between nodes: 100 m max.
Noise immunity	Conforms to IEC 61000-4-4, 1 kV or higher
Node address setting method	Set with decimal rotary switches or software* ¹
Node address range	000 to 192* ²

*1. The software setting is used when the node address setting switches are set to 0.

*2. The range depends on the EtherCAT master that is used. Refer to the *E3NW-ECT EtherCAT Digital Sensor Communications Unit Operation Manual* (Cat. No. E429) for details.

Safety Precautions

This document provides information that is necessary to select products. It does not contain precautions for using the products.

Always read the Instruction Manual and the Operation Manual (Cat. No. E429) before you attempt to use any of the products.

Sensor Communications Unit CompoNet

Item	Model	E3NW-CRT
Connectable Sensor Amplifier Units		N-Smart Smart Fiber Amplifier Unit: E3NX-FA0 Smart Laser Amplifier Unit: E3NC-LA0 Smart Laser Amplifier Unit (CMOS type): E3NC-SA0
Power supply voltage		14 to 26.4 VDC
Power and current consumption		At 24 VDC 1.7 W max. (Not including the power supplied to Sensors.), 70 mA max. (Not including the current supplied to Sensors.)
Indicators		MS (Machine Status) indicator (green/red), NS (Network Status) indicator (green/red), and SS (Sensor Status) indicator (green/red)
Vibration resistance (destruction)		10 to 60 Hz with a 0.7-mm double amplitude, 50 m/s ² at 60 to 150 Hz, for 1.5 hours each in X, Y, and Z directions
Shock resistance (destruction)		150 m/s ² for 3 times each in X, Y, and Z directions
Ambient temperature range		Operating: 0 to 55°C;*1 Storage: -30 to 70°C (with no icing or condensation)
Ambient humidity range		Operating and storage: 25% to 85% (with no condensation)
Maximum connectable Sensors*1		16*2
Maximum connectable Distributed Sensor Units		8
Insulation resistance		20 MΩ min. (at 500 VDC)
Dielectric strength		500 VAC at 50/60 Hz for 1 min
Mounting method		35-mm DIN track - mounting
Weight (packed state/Unit only)		Approx. 165 g/approx. 70 g
Materials		Polycarbonate
Accessories		Communications connector for E3NW-DS connection, DIN Track End Plates (2 pieces), and instruction manual

*1. Temperature Limitations Based on Number of Connected Amplifier Units:

Groups of 1 or 2 Amplifier Units: 0 to 55°C, Groups of 3 to 10 Amplifier Units: 0 to 50°C, Groups of 11 to 16 Amplifier Units: 0 to 45°C

*2. This is the total number of Sensors that can be connected to the Sensor Communications Unit and Distributed Sensor Units.

Communications Specifications

Item	Specifications
Communications method	Dedicated protocol for CompoNet
Types of communications	Remote I/O communications (program-free, constant sharing of data) and message communications (explicit message communications as required)
Baud rate	4 Mbps, 3 Mbps, 1.5 Mbps, 93.75 kbps
Modulation	Baseband method
Coding	Manchester code
Error control	Manchester encoding rules and CRC
Communications media	The following media can be used. •Round Cable I •Round Cable II •Flat Cable I (DCA4-4F10 Standard Flat Cable) •Flat Cable II (DCA5-4F10 Sheathed Flat Cable) Note: Round Cable I, Round Cable II, Flat Cable I, and Flat Cable II cables are all treated as different types of cables. When two or more types of cables are used in a single network, a Repeater Unit must be used to separate any two different types of cables between the trunk line and a sub-trunk line.
Communications distance and wiring	Refer to <i>1-2-1 Cable Types, Maximum Distances, and Number of Slave Units in the CompoNet Master Units Operation Manual (Cat. No. W456)</i> .
Signal lines	Two lines: BDH (communications data high) and BDL (communications data low)
Power lines	Two lines: BS+ and BS- (power for communications and internal Slave Unit circuits) •Power is supplied from the Master Unit or Repeater Unit.
Connection forms	Round Cable II, Flat Cable I, or Flat Cable II at a baud rate of 93.75 kbps: No restrictions Other cables or baud rates: Trunk line and branch lines Connections for Slave Units and Repeater Units: T-branch or multidrop connections
Noise immunity	Conforms to IEC 61000-4-4, 1 kV or higher
Address setting method	Decimal rotary address switch
Address range	0 to 62

Safety Precautions

This document provides information that is necessary to select products. It does not contain precautions for using the products.

Always read the Instruction Manual and the Operation Manual (Cat. No. E430) before you attempt to use any of the products.

Sensor Communications Unit CC-Link

Item	Model	E3NW-CCL
Connectable Sensor Amplifier Units		N-Smart Smart Fiber Amplifier Unit: E3NX-FA0 Smart Fiber Amplifier Unit (Infrared models): E3NX-FAH0 Smart Fiber Amplifier Unit (2-channel models): E3NX-MA0 Smart Laser Amplifier Unit: E3NC-LA0 Smart Laser Amplifier Unit (CMOS type): E3NC-SA0 Smart Proximity Amplifier Unit: E2NC-EA0 E2NC-EA10 E2NC-EA40 Contact-Type Smart Amplifier Unit: E9NC-TA0 *1
Power supply voltage		24 VDC (20.4 to 26.4 V)
Power and current consumption		2.4 W max. (Not including the power supplied to Sensors.), 100 mA max. (Not including the current supplied to Sensors.)
Indicators		RUN indicator (green), ERROR indicator (red), and SS (Sensor Status) indicator (green/red)
Vibration resistance (destruction)		10 to 60 Hz with a 0.7-mm double amplitude, 50 m/s ² at 60 to 150 Hz, for 1.5 hours each in X, Y, and Z directions
Shock resistance (destruction)		150 m/s ² for 3 times each in X, Y, and Z directions
Ambient temperature range		Operating: 0 to 55°C; *2 Storage: -30 to 70°C (with no icing or condensation)
Ambient humidity range		Operating and storage: 25% to 85% (with no condensation)
Maximum connectable Sensors *2		16 *3
Maximum connectable Distributed Sensor Units		8
Insulation resistance		20 MΩ min. (at 500 VDC)
Dielectric strength		500 VAC at 50/60 Hz for 1 min
Mounting method		35-mm DIN track - mounting
Weight (packed state/Unit only)		Approx. 180 g/approx. 80 g
Materials		Polycarbonate
Accessories		Power Supply Connector, E3NW-DS Communications Connector, Network Connectors (2), DIN Track End Plates (2), and Instruction Manual

*1. The E9NC-TA0 is supported for firmware version 1.03 or higher (Sensor Communications Units manufactured in July 2014 or later).

*2. Temperature Limitations Based on Number of Connected Amplifier Units:

Groups of 1 or 2 Amplifier Units: 0 to 55°C, Groups of 3 to 10 Amplifier Units: 0 to 50°C, Groups of 11 to 16 Amplifier Units: 0 to 45°C

*3. This is the total number of Sensors that can be connected to the Sensor Communications Unit and Distributed Sensor Units.

Communications Specifications

Item	Specifications
Communications protocol	Dedicated protocol for CC-Link
Communications method	Broadcast polling
Baud rate	10 Mbps/5 Mbps/2.5 Mbps/625 kbps/156 kbps
Physical layer	Bus (based on EIA RS485)
Topology	Daisy chain (T-branching can be used.)
Communications media	CC-Link Cables
Communications distance	Cable length between nodes: 20 cm min. Maximum total cable length Baud rate of 156 kbps: 1,200 m Baud rate of 625 kbps: 900 m Baud rate of 2.5 Mbps: 400 m Baud rate of 5 Mbps: 160 m Baud rate of 10 Mbps: 100 m
Noise immunity	Conforms to IEC 61000-4-4, 1 kV or higher
Address setting method	Decimal rotary address switch
Address range	64 max.*
Synchronization mode	Cyclic transmissions (synchronization)

* The range depends on the CC-Link master that is used. Refer to 5-3-2 Node Setting Switches in the E3NW-CCL CC-Link Digital Sensor Communications Unit Operation Manual (Cat. No. E431) for details.

Safety Precautions

This document provides information that is necessary to select products. It does not contain precautions for using the products.

Always read the Instruction Manual and the Operation Manual (Cat. No. E431) before you attempt to use any of the products.

Distributed Sensor Unit

Item	Model	E3NW-DS
Connectable Sensor Amplifier Units		N-Smart Smart Fiber Amplifier Unit: E3NX-FA0 Smart Fiber Amplifier Unit (Infrared models): E3NX-FAH0 Smart Fiber Amplifier Unit (2-channel models): E3NX-MA0 Color Fiber Amplifier Unit: E3NX-CA0 Smart Laser Amplifier Unit: E3NC-LA0 Smart Laser Amplifier Unit (CMOS type): E3NC-SA0 Smart Proximity Amplifier Unit: E2NC-EA0 E2NC-EA10 E2NC-EA40 Contact-Type Smart Amplifier Unit: E9NC-TA0
Power supply voltage		24 VDC (20.4 to 26.4 V)
Power and current consumption		2 W max. (Not including the power supplied to Sensors.), 80 mA max. (Not including the current supplied to Sensors.)
Indicators		RUN indicator (green) and SS (Sensor Status) indicator (green/red)
Vibration resistance (destruction)		10 to 60 Hz with a 0.7-mm double amplitude, 50 m/s ² at 60 to 150 Hz, for 1.5 hours each in X, Y, and Z directions
Shock resistance (destruction)		150 m/s ² for 3 times each in X, Y, and Z directions
Ambient temperature range		Operating: 0 to 55°C;* Storage: -30 to 70°C (with no icing or condensation)
Ambient humidity range		Operating and storage: 25% to 85% (with no condensation)
Maximum connectable Sensors*		10
Insulation resistance		20 MΩ min. (at 500 VDC)
Dielectric strength		500 VAC at 50/60 Hz for 1 min
Mounting method		35-mm DIN track - mounting
Weight (packed state/Unit only)		Approx. 160 g/approx. 40 g
Materials		Polycarbonate
Accessories		Power supply/communications connector, DIN Track End Plates (2 pieces), ferrite cores (2 pieces), and instruction manual

* Temperature Limitations Based on Number of Connected Amplifier Units:
Groups of 1 or 2 Amplifier Units: 0 to 55°C, Groups of 3 to 10 Amplifier Units: 0 to 50°C