

VoltageWatch sensor



The Eaton VoltageWatch™ sensor is a high-performance, true RMS sensor for sensing voltage in single- and three-phase installations. Applicable on nominal circuits of 120V, 240V and 480V, this voltage sensor provides a fully isolated analog output proportional to rated nominal voltage in both sinusoidal and non-sinusoidal (variable frequency) situations. It is housed in a slim, compact, easy-to-install DIN rail mount enclosure.

Ideal for situations where power quality is of interest or concern, the VoltageWatch sensor facilitates monitoring of supply voltage levels, identifying undervoltage or overvoltage conditions, and helping to protect critical motors and electronics. Designed with an industry-standard 4–20 mA output, VoltageWatch is easily coupled to a data logger, panel meter or PLC to enable basic trending of operational status of low voltage circuits up to real-time monitoring and reporting of supply voltage levels.

Features

- **True RMS output**
Allows for use in situations where power supplied is non-sinusoidal, such as VFD applications, poor power quality installations or other electrically harsh/challenging environments
- **Standard 4–20 mA loop-powered output**
Industry standard output works easily and reliably with existing controllers, data loggers and SCADA equipment

- **Input/output isolation**
Input and output circuitry is electrically isolated for improved safety
- **Compact DIN rail mount enclosure**
Space-saving 35 mm wide enclosure mounts quickly for an attractive installation

Applications

True RMS voltage monitoring

- Detect below-normal or “brown out” voltage conditions; protect against possible motor overheating
- Identify phase-loss conditions by detecting voltage reduction in one or more phases of a three-phase motor
- Monitor overvoltage conditions associated with regenerative voltage to help in diagnosing/avoiding motor drive issues
- Detect voltage conditions that may cause stress in or damage to soft starter components (SCRs)



Powering Business Worldwide

Phase-loss protection

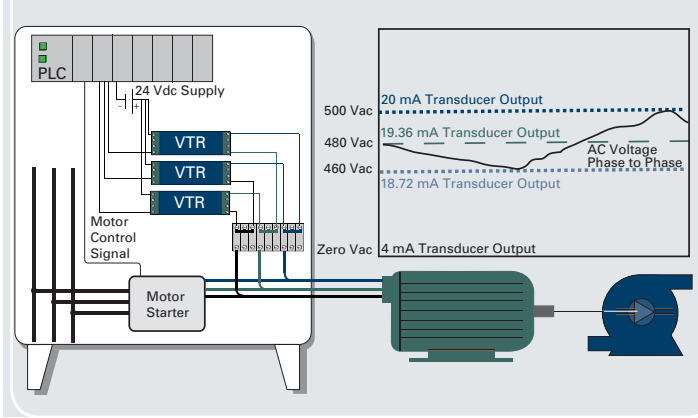

Dimensions in inches (mm)

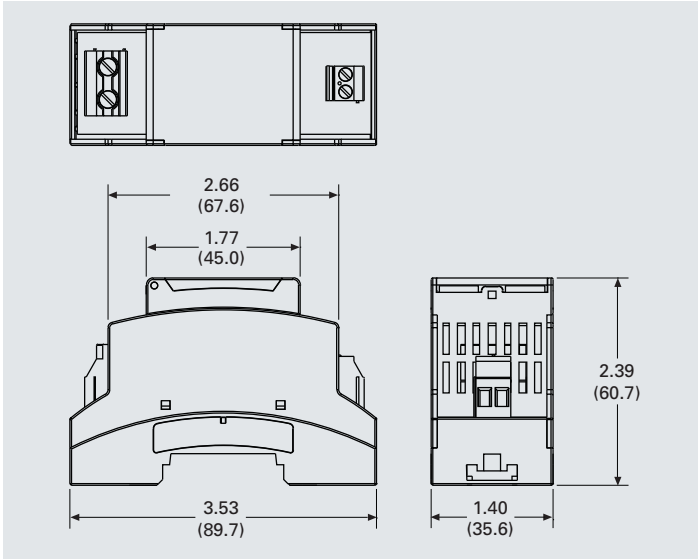

Connections

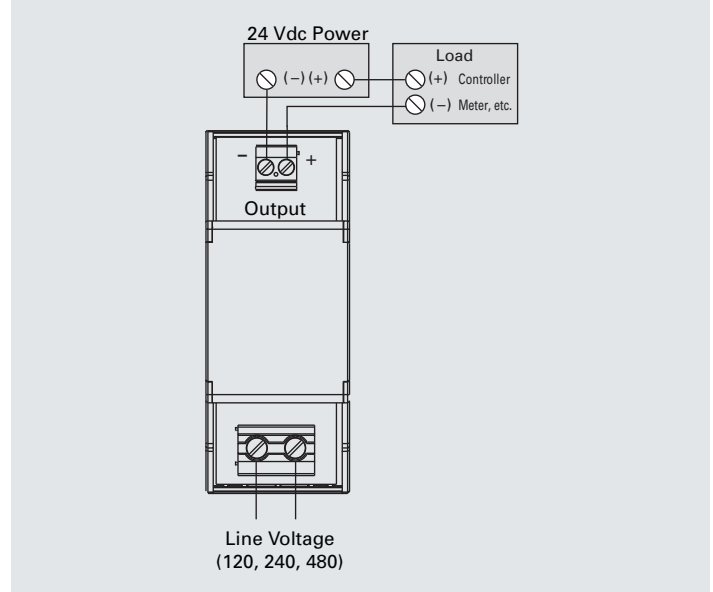

Specifications

Power supply	24 Vdc loop-powered
Input	120V, 240V, 480V
Input over-range	+15% of nominal range
Output	4 to 20 mA proportional; capped at 24 mA max.
Response time	250 ms (to 90% value)
Accuracy	<1%
Linearity	<0.5%
Loading	<500 ohms
Isolation voltage	2500 Vac
Frequency range	40 Hz–5 kHz
Operating temperature	–22 to 140°F (–30 to 60°C)
Mounting	DIN rail compatible
Case	UL® 94 V0 flammability rated; noncorrosive thermoplastic
Environmental	14 to 122°F (–10 to 50°C), 0–95% RH noncondensing
EMC/Immunity	EN50081-1, EN50082-2
Ripple	<1% (peak to peak)
Listings	UL/cUL® and CE pending

Catalog numbering system

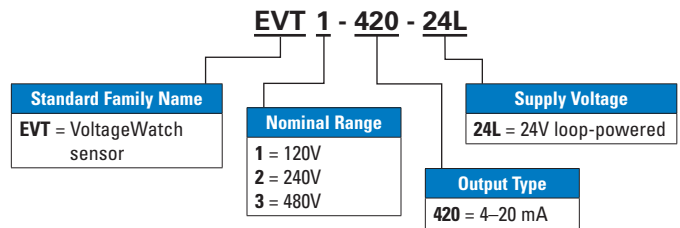

Eaton
1000 Eaton Boulevard
Cleveland, OH 44122
United States
Eaton.com

© 2013 Eaton
All Rights Reserved
Printed in USA
Publication No. PA05311002E / Z13426
June 2013

EATON
Powering Business Worldwide

Eaton is a registered trademark.
All other trademarks are property of their respective owners.