

Cycle Control Unit G32A-EA

Used in Combination with the G3PA SSR to Enable High-precision Temperature Control

- Uses cycle control to achieve power control with little noise.
- Used in combination with the G3PA SSR to connect to single- and three-phase loads.
- Three types of input method available: Internal adjuster, external adjuster, or DC signals from 4 to 20 mA.
- Streamline design. Both DIN-track mounting and screw mounting possible.
- Uses linking terminals for close mounting with G3PA SSR.
- Built-in isolation transformer.
- Power supply range: 100 to 240 V.



Ordering Information

Name	Isolation transformer	Rated power supply voltage	Model
Cycle Control Unit	Yes	100 to 240 VAC	G32A-EA

Application Examples

- Electric furnaces
- Thermostats
- Food-processing machinery
- Drying machinery
- Molding equipment
- Heating devices
- Other applications requiring high-precision temperature control

Specifications

■ Ratings

Item		Specifications
Rated power supply current	50 Hz	100 (200) VAC
		120 (240) VAC
	60 Hz	100 (200) VAC
		120 (240) VAC
Output signal	15 mA max. at 12 VDC \pm 15% (at 25°C)	
Input signal	Current signal: 4 to 20 mA (input impedance: 352 Ω) (see note) Internal adjuster: 50 k Ω (1/4 W) External adjuster: 50 k Ω (1/4 W)	
Output cycle rate	0 to 100%	
Control cycle	0.2 s	
Number of operable units	2 G3PA Relays max.	

Note: The values given for current signals are for operation at room temperature.

■ Characteristics

Item	Specifications
Power supply voltage range	75 to 264 VAC
Dielectric strength	1,500 VAC, 50/60 Hz for 1 minute (between AC power supply and input/output terminals)
Vibration resistance	10 to 55 Hz, double amplitude of 0.75 mm ² (when mounted to DIN track)
Shock resistance	300 m/s ² (approx. 30 G)
Storage temperature	-30 to 100°C (with no icing or condensation)
Ambient operating temperature	-30 to 80°C (with no icing or condensation)
Ambient operating humidity	45% to 85%
Weight	Approx. 100g

Engineering Data

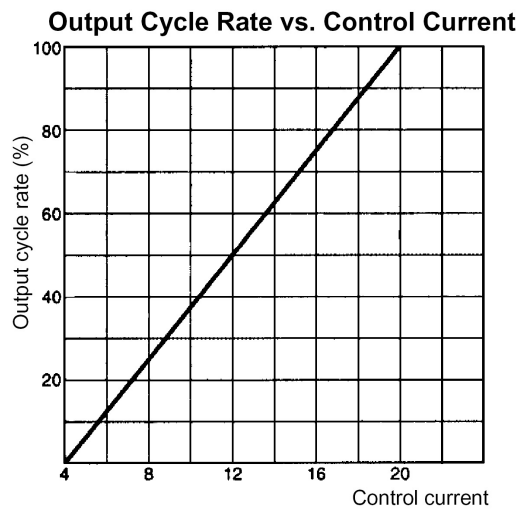
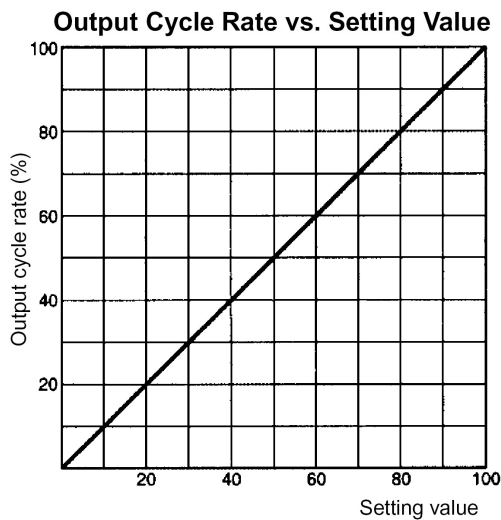

Nomenclature

The following diagram shows the terminals, adjusters, and switches of the G32A-EA.

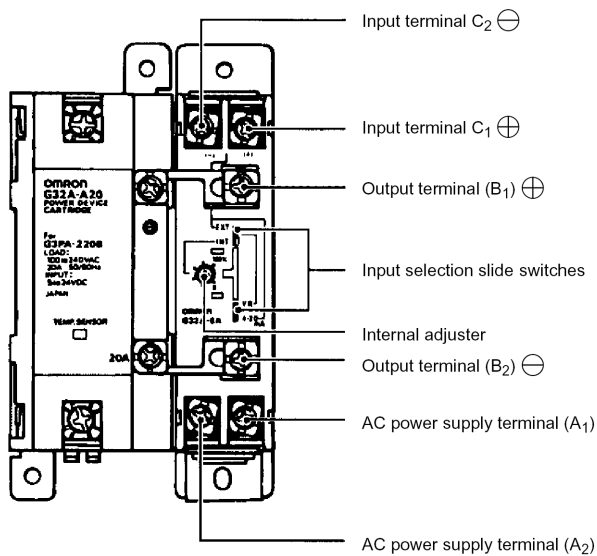

■ Setting the Input Method

Select external adjuster, internal adjuster, or control current as the input method using the selection switches as shown in the following table.

Control method	Input selection slide switches
External adjuster	
Internal adjuster (see note 2)	
Control current	

- Note: 1.** The input selection slide switches are factory set to internal adjuster input. Change the setting of the switches for the input method required.
- 2.** When using the internal adjuster, use with the input terminals (C₁, C₂) in the open state. Internal setting is not possible if there is a Temperature Controller or other device connected to C₁ or C₂.

■ Cycle Control Setting Method

The output cycle rate can be adjusted using the internal or external adjuster. For current control, refer to the Output Cycle Rate vs Control Current graph on page 2.

Note: When using the internal adjuster or external adjuster, it is necessary to set the input control method in the way described previously.

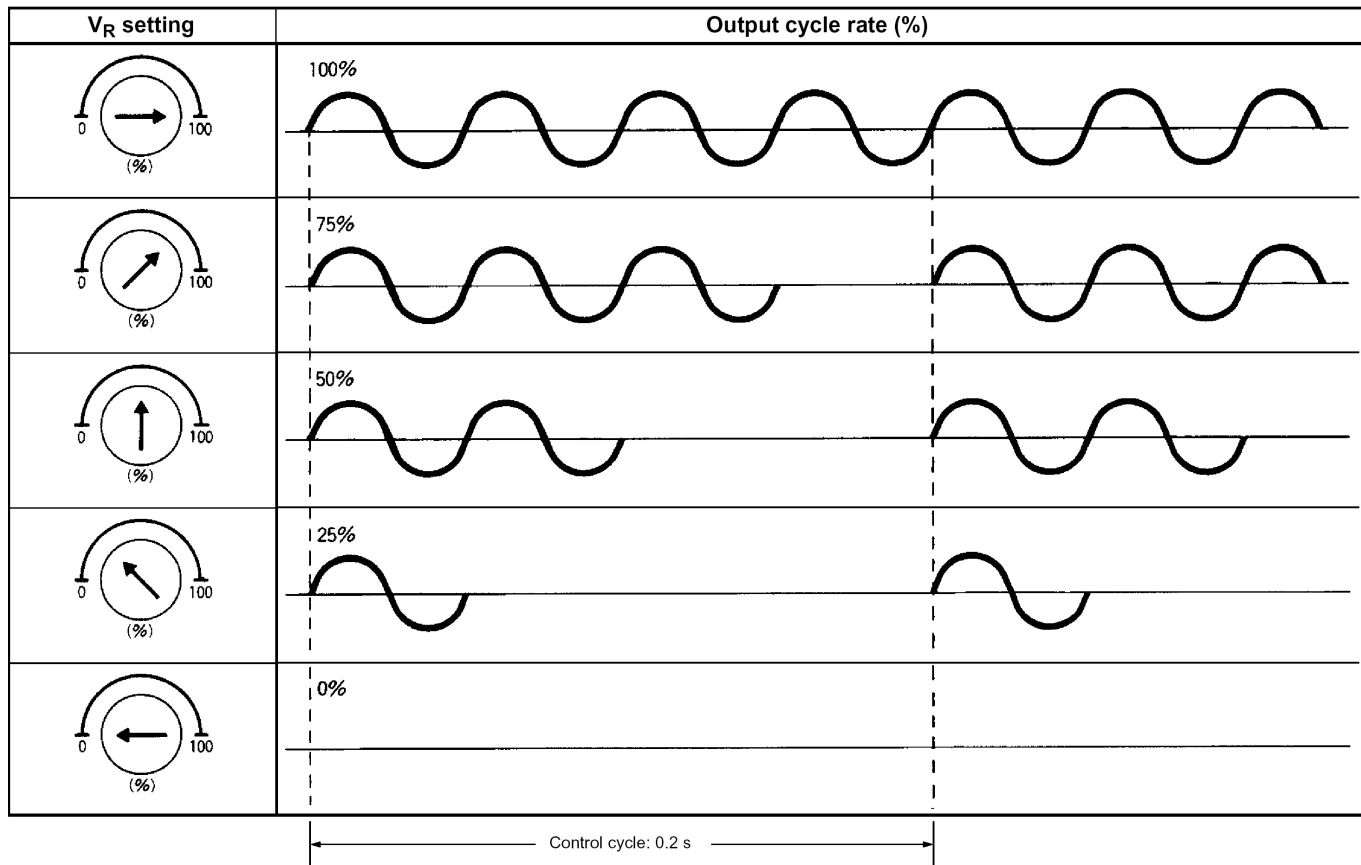

■ Output Power Resolution

When power is controlled using the Cycle Control Unit, the output resolution (minimum variation value) changes depending on the power supply frequency. (SSR with zero cross function.)

Control cycle	Output power resolution	
	50 Hz	60 Hz
0.2 s	5%	4.2%

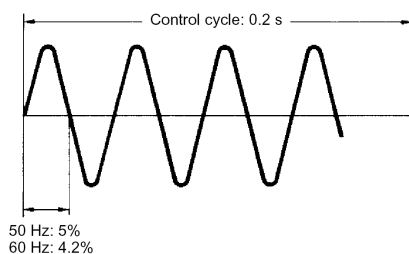

■ Cycle Control Method

The power on the load side can be controlled by adjusting the number of cycles within the control cycle of 0.2 s and repeating this control cycle.

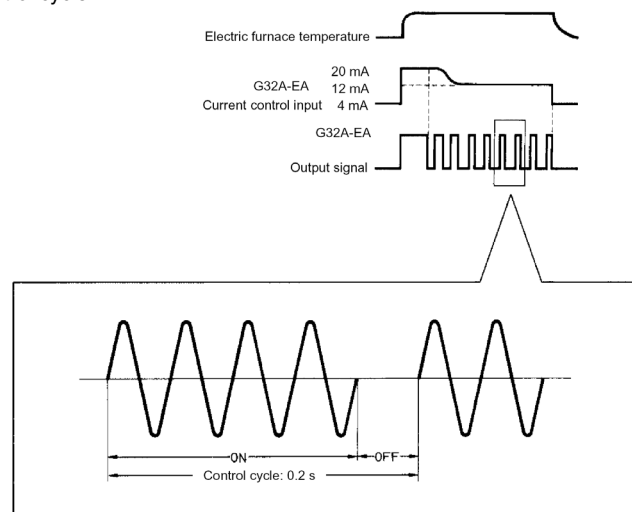

Operation

Application Examples

High-precision temperature control can be achieved in combination with the G3PA.

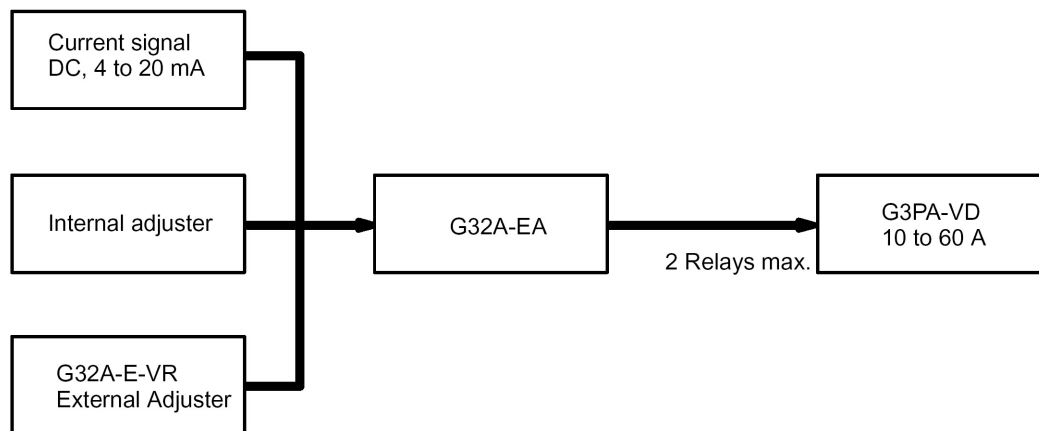

1. Control Using Current Input

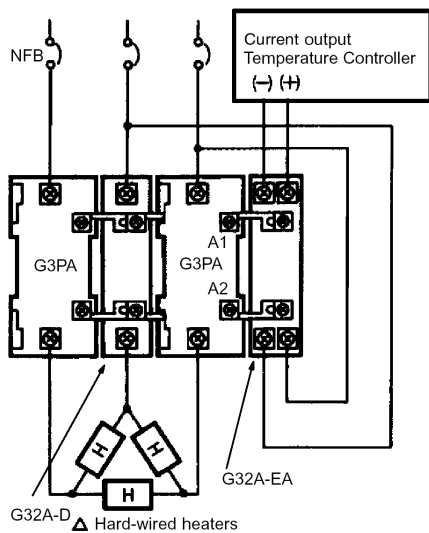

3. Control Using Internal Adjuster

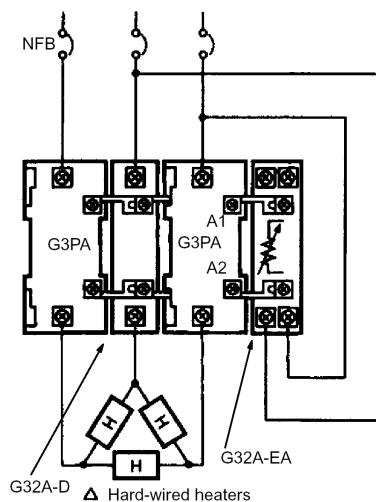

2. Control Using External Adjuster

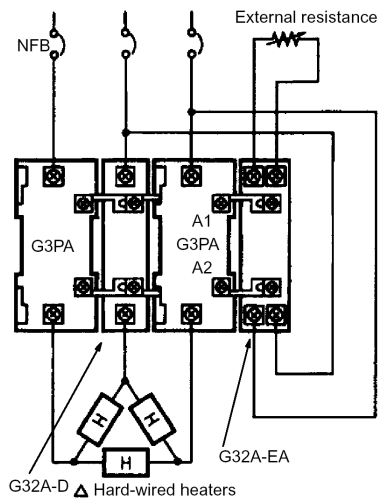

Applications 1, 2, and 3 each use a different type of input method and so it is necessary to change the settings of the input selection slide switches. Be sure to change the slide switch settings in accordance with the input method.

Note: 1. For details of input selection slide switch settings, refer to *Setting the Input Method*.

2. The above examples are for when a G3PA-VD (except 60-A models) is used at 200 VAC.

External Adjuster

G32A-E-VR

The external adjuster, its adjuster knob, and its nameplate, all come in a set (G32A-E-VR).

External Adjuster (50 kΩ, B Characteristic)

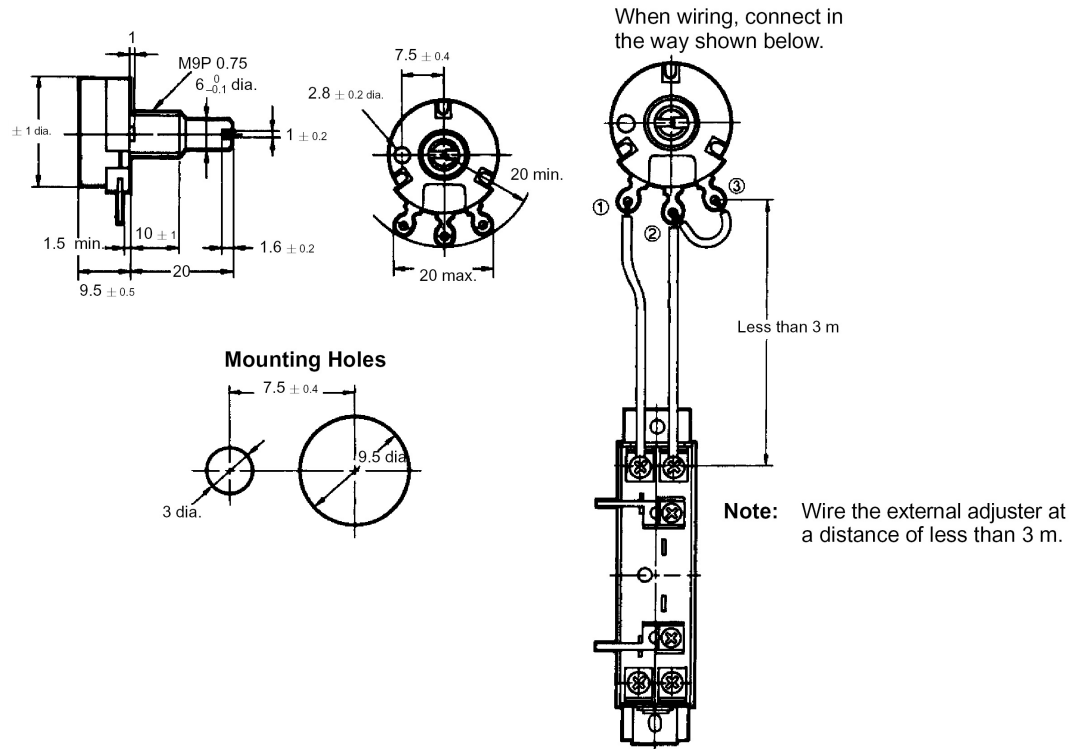

Note: When using the external adjuster for input, be sure to set the input selection slide switches accordingly.

Nameplate

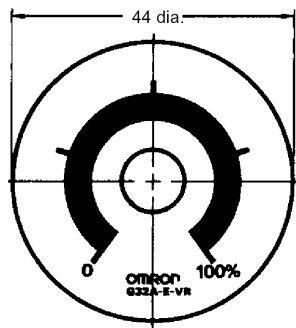

Knob

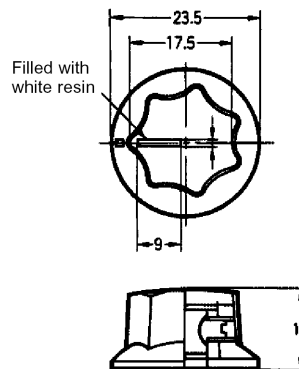

Dimensions

Unit: mm

■ G32-EA

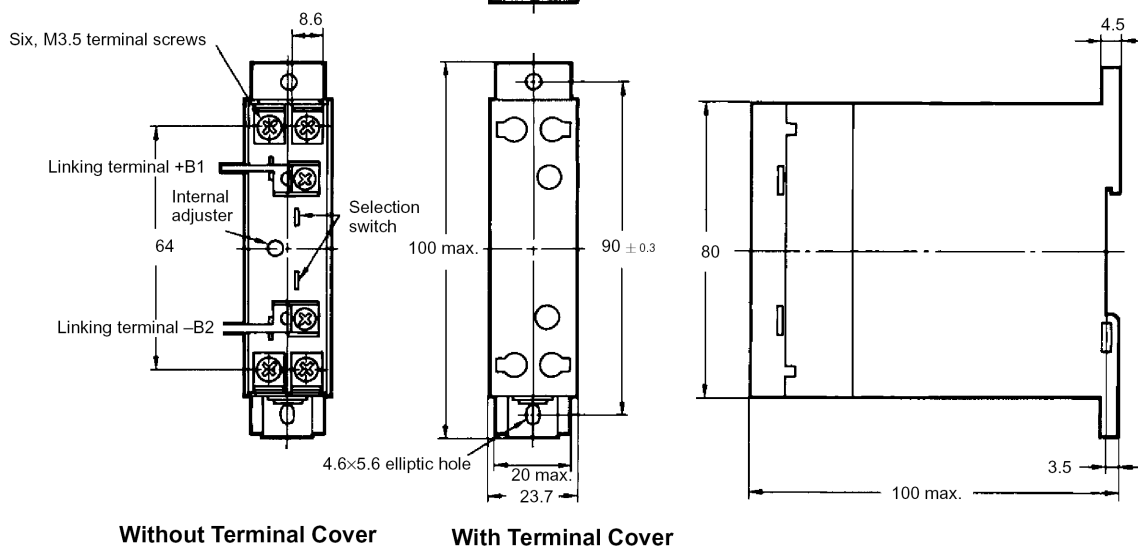
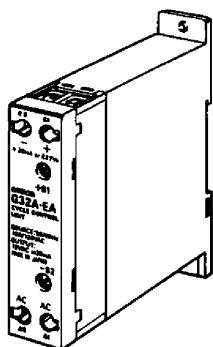

Without Terminal Cover

With Terminal Cover

Terminal Arrangement/Internal Connection

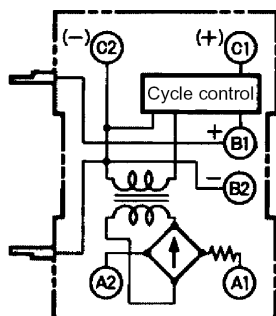

Mounting Holes

