

DH362NRK Safety Switch



1.1 Safety Switches

Product Overview	V2-T1-2
Cross-Reference	V2-T1-3
Catalog Number Selection	V2-T1-11
Options and Accessories	V2-T1-13
Modifications—Flex Center	V2-T1-15
Standard Lug Capacities	V2-T1-16
Short-Circuit Ratings	V2-T1-21
Typical Fuse Dimensions	V2-T1-23
General Duty	V2-T1-25
Heavy-Duty	V2-T1-30
Heavy-Duty Double Door Safety Switch	V2-T1-39
Six-Pole Switches	V2-T1-43
Double-Throw Switches	V2-T1-46
EnviroLine Stainless Steel Switch	V2-T1-53
Window Switches	V2-T1-57
Receptacle Switches	V2-T1-60
Non-Metallic KRYDON Switch	V2-T1-62
Shunt Trip Safety Switch	V2-T1-65
NEMA 7/9—Hazardous Location Disconnect Switch	V2-T1-68
Quick-Connect Switches	V2-T1-70
Solar Disconnect Switch	V2-T1-75
Mill-Duty Rated, Heavy-Duty Safety Switch	V2-T1-77
Heavy-Duty Fusible Safety Switches Accepting CUBEFuses	V2-T1-79
Elevator Control Switch	V2-T1-82
Auxiliary Power Heavy-Duty Safety Switch	V2-T1-85
Left-Handed Safety Switch	V2-T1-89
Heavy-Duty Surge Switch	V2-T1-90
OEM Line Isolation (OLI) Switch	V2-T1-92
Pringle Bolted Pressure Switch	V2-T1-95
Type DS, Fusible and Non-Fusible	V2-T1-98
Type Visi-Flex DE-ION	V2-T1-101
Flange Mounted—Variable Depth	V2-T1-105
Flange Mounted—Fixed Depth	V2-T1-109

1.2 Enclosed Circuit Breakers

Enclosed Circuit Breaker (ECB) with Arcflash Reduction Maintenance System	V2-T1-111
Product Selection	V2-T1-112
Wiring Diagram	V2-T1-113
Dimensions	V2-T1-114
Enclosed Circuit Breakers	V2-T1-115
Cross-Reference	V2-T1-117
Product Selection	V2-T1-119
Accessories	V2-T1-120
Flex Center	V2-T1-122
Technical Data and Specifications	V2-T1-123
Dimensions	V2-T1-125

1.3 Enclosed Rotary Disconnects

Product Overview	V2-T1-132
Product Selection	V2-T1-133
Dimensions	V2-T1-134

Revision notes

Volume 2—Commercial Distribution, CA08100003E

Tab 1—Switching Devices

Revision date	Section	Change page(s)	Description
04/29/2019	All	All	Updated to April 2019 print revision date



Powering Business Worldwide

Product Overview

Product Selection Guide

Safety Switch

Switch Type	NEMA Rating	Fused/non-fused	Number of Poles				
			1	2	3	4	6
Heavy-duty single-throw	NEMA 1	Fused and non-fused ^①	—	30–800A	30–1200A	30–600A	—
	NEMA 3R	Fused and non-fused ^②	30–600A	30–800A	30–1200A	—	—
	NEMA 12/3R	Fused and non-fused ^{①②}	30–600A	30–800A	30–1200A	30–600A	30–200A
	NEMA 4	Fused and non-fused	—	400–800A	400–800A	—	—
	NEMA 7/9	Fused and non-fused ^③	—	—	30–100A	—	—
	NEMA 4X Non-Metallic	Fused and non-fused ^③	—	—	30–200A	—	—
	NEMA 4X stainless-steel (304 or 316 grade)	Fused and non-fused ^{①②}	30–600A	30–800A	30–1200A	30–600A	30–200A
General-duty single-throw	NEMA 1	Plug fuse	30A	30A	—	—	—
	NEMA 1 and 3R	Fused	—	30–600A	30–600A	—	—
	NEMA 1	Non-fused	—	30–100A	30–600A	—	—
	NEMA 3R	Non-fused	—	30–200A	30–600A	—	—
Heavy-duty double-throw	NEMA 1	Fused	—	200A	30–1200A	—	—
	NEMA 3R	Fused ^④	—	200A	100–1200A	—	—
	NEMA 12	Fused	—	—	30–400A	—	—
	NEMA 4X stainless-steel (304 or 316 grade)	Fused	—	—	30–400A	—	—
	NEMA 1	Non-fused	—	30–1200A	30–1200A	200–800A	—
	NEMA 3R	Non-fused ^④	—	200–1200A	30–1200A	30–800A	30–100A
	NEMA 12	Non-fused	—	—	30–800A	—	—
NEMA 4X stainless-steel (304 or 316 grade)	Non-fused	—	—	30–800A	—	—	
General-duty double-throw	NEMA 3R	Non-fused	—	30–400A	—	—	—
Shunt trip safety switches	NEMA 1, 3R, 4, and 12	Fused and non-fused	—	30–800A	30–800A	30–400A	—
Window switches	NEMA 12/3R and 4X stainless-steel (304 or 316 grade)	Fused and non-fused ^①	—	30–1200A	30–1200A	30–600A	30–200A
Enviroline stainless-steel switch	NEMA 4X (304 or 316 grade)	Fused and non-fused ^⑤	—	30–400A	30–400A	—	—
Mill Duty Switches	NEMA 12/3R and 4X stainless-steel (304 or 316 grade)	Fused and non-fused	—	30–600A	30–600A	—	—
Quick connect double-throw	NEMA 1 and 3R	Fused and non-fused ^④	—	100–1200A	100–1200A	100–1200A	—
Quick connect single-throw	NEMA 1 and 3R	Fused and non-fused ^④	—	100–1200A	100–1200A	100–1200A	—
Elevator control switches	NEMA 1, 3R, 4, and 12	Fused	—	—	30–400A	—	—
OEM Line Isolation Switches (OLI)	NEMA 12/3R and 4X stainless-steel (304 or 316 grade)	Fused and non-fused	—	30–400A	30–400A	—	—
Receptacle switches	NEMA 12/3R and 4X stainless-steel (304 or 316 grade)	Fused and non-fused ^⑥	—	—	30–100A	—	—
Auxiliary power switch	NEMA 3R	Fused and non-fused ^④	—	—	30–200A	—	—
Left-handed switches	NEMA 1, 3R, 12, and 4X stainless-steel (304 or 316 grade)	Fused and non-fused ^⑦	—	—	30–200A	—	—
Heavy-duty CUBEFuse [®]	NEMA 1	Fused	—	—	30–100A	30–100A	—
	NEMA 3R	Fused	—	—	30–100A	—	—
	NEMA 12/3R	Fused	—	—	30–100A	100A	—
	NEMA 4X stainless-steel (304 or 316 grade)	Fused	—	—	30–100A	—	—
Surge switches	NEMA 12/3R and 4X stainless-steel (304 or 316 grade)	Fused and non-fused	—	30–1200A	30–1200A	—	—
Heavy-duty double door	NEMA 12/3R and 4X stainless-steel (304 or 316 grade)	Fused	—	30–1200A	30–1200A	—	—
Enclosed rotary	NEMA 1, 12/3R, NEMA 4X stainless-steel	Non-fused	—	—	16–80A	16–80A	—
	NEMA 4X non-metallic	Non-fused	—	—	16–80A	16–80A	—
	NEMA 4X polycarbonate non-metallic	Non-fused	—	—	30A and 60A	16–80A	—

Notes

^① 400–800A 6-pole, and 800A 4-pole heavy-duty, single-throw switches are non-UL Listed and available.

^② Single-pole product is the single circuit 600 Vdc switch series.

^③ No viewing windows or other enclosure modifications are available with this product.

^④ NEMA 3R stainless versions are available and are UL Listed.

^⑤ Enviroline stainless-steel switches have stainless-steel enclosures, sub pans, handles, and mechanisms.

^⑥ Switches with non-standard receptacles or at higher amperages are non-UL Listed and available.

^⑦ All left-handed switches are non-UL Listed. Higher amperages are not available.

Cross-Reference

General-Duty

Ampere Rating	Catalog Number			
	Eaton	General Electric	Siemens	Square D
Plug Fuse, Single-Pole, Two-Wire, 120 Vac, NEMA 1				
30	DP111NGB	TPF130	LF111N	D211N
Plug Fuse, Two-Pole, Three-Wire, 240 Vac, NEMA 1				
30	DP221NGB	TPF230	LF211N	D211N
Fusible, Two-Pole, Three-Wire, 240 Vac, NEMA 1				
30	DG221NGB	TG3221	GF221N	D221N
60	DG222NGB	TG3222	GF222N	D222N
100	DG223NGB	TG3223	GF223N	D223N
200	DG224NGK	TG3224	GF224N	D224N
400	DG225NGK	TG3225	GF225N	D225N
600	DG226NGK	TG3226	GF226N	D226N
Fusible, Three-Pole, Three-Wire, 240 Vac, NEMA 1				
30	DG321NGB	TG4321	GF321N	D321N
60	DG322NGB	TG4322	GF322N	D322N
100	DG323NGB	TG4323	GF323N	D323N
200	DG324NGK	TG4324	GF324N	D324N
400	DG325FGK	TG3325	GF325N	D325N
600	DG326FGK	TG3326	GF326N	D326N
Fusible, Three-Pole, Four-Wire, 240 Vac, NEMA 1				
30	DG321NGB	TG4321	GF321N	D321N
60	DG322NGB	TG4322	GF322N	D322N
100	DG323NGB	TG4323	GF323N	D323N
200	DG324NGK	TG4324	GF324N	D324N
400	DG325NGK	TG4325	GF325N	D325N
600	DG326NGK	TG4326	GF326N	D326N
Non-Fusible, Two-Pole, Two-Wire, 240 Vac, NEMA 1				
30	DG221UGB	TGN3321	N/A	N/A
60	DG222UGB	TGN3322	N/A	Q0260NATS
100	DG223UGB	TGN3323	N/A	Q02000NS
200	DG324UGK	TGN3324	N/A	DU324
400	DG325UGK	TGN3325	N/A	DU325
600	DG326UGK	TGN3326	N/A	DU326
Non-Fusible, Three-Pole, Three-Wire, 240 Vac, NEMA 1				
30	DG321UGB	TGN3321	GNF321	DU321
60	DG322UGB	TGN3322	GNF322	DU322
100	DG323UGB	TGN3323	GNF323	DU323
200	DG324UGK	TGN3324	GNF324	DU324
400	DG325UGK	TGN3325	GNF325	DU325
600	DG326UGK	TGN3326	GNF326	DU326

General-Duty, continued

Ampere Rating	Catalog Number			
	Eaton	General Electric	Siemens	Square D
Fusible, Two-Pole, Three-Wire, 240 Vac, NEMA 3R				
30	DG221NRB	TG3221R	GF221NR	D221NRB
60	DG222NRB	TG3222R	GF222NR	D222NRB
100	DG223NRB	TG3223R	GF223NR	D223NRB
200	DG224NRK	TG3224R	GF224NR	D224NRB
400	DG225NRK	TG3225R	GF225NR	D225NR
600	DG226NRK	TG3226R	GF226NR	D226NR
Fusible, Three-Pole, Three-Wire, 240 Vac, NEMA 3R				
30	DG321NRB	TG4321R	GF321NR	D321NRB
60	DG322NRB	TG4322R	GF322NR	D322NRB
100	DG323NRB	TG4323R	GF323NR	D323NRB
200	DG324NRK	TG4324R	GF324NR	D324NRB
400	DG325FRK	TG3325R	GF325NR	D325NR
600	DG326FRK	TG3326R	GF326NR	D326NR
Fusible, Three-Pole, Four-Wire, 240 Vac, NEMA 3R				
30	DG321NRB	TG4321R	GF321NR	D321NRB
60	DG322NRB	TG4322R	GF322NR	D322NRB
100	DG323NRB	TG4323R	GF323NR	D323NRB
200	DG324NRK	TG4324R	GF324NR	D324NRB
400	DG325NRK	TG3325R ^①	GF325NR	D325NR
600	DG326NRK	TG3326R ^①	GF326NR	D326NR
Non-Fusible, Two-Pole, Two-Wire, 240 Vac, NEMA 3R				
30	DG221URB	TGN3321R	GNF321R	DU221RB
60	DG222URB	TGN3322R	GNF322R	DU222RB
100	DG223URB	TGN3323R	GNF323R	Q02000NRB
200	DG324URK	TGN3324R	GNF324R	DU324RB
Non-Fusible, Three-Pole, Three-Wire, 240 Vac, NEMA 3R				
30	DG321URB	TGN3321R	GNF321R	DU321RB
60	DG322URB	TGN3322R	GNF322R	DU322RB
100	DG323URB	TGN3323R	GNF323R	DU323RB
200	DG324URK	TGN3324R	GNF324R	DU324RB
400	DG325URK	N/A	N/A	N/A
600	DG326URK	N/A	N/A	N/A

Notes

^① Separate neutral kit required.

Always verify the number of poles and wires required since catalog numbers may appear in multiple tables.

Heavy-Duty

Ampere Rating	Catalog Number		General Electric	Siemens	Square D
	Eaton				
Fusible, Two-Pole, Two-Wire, 240 Vac, NEMA 1					
30	DH221FGK		TH3221	N/A	H221N
60	DH222NGK		TH3222	N/A	H222N
100	DH223NGK		TH3223	N/A	H223N
200	DH224NGK		TH3224	N/A	H224N
400	DH225FGK		TH3225	N/A	H225
600	DH226FGK		TH3226	N/A	H226
800	DH227FGK		TC72267	N/A	H227
1200	DH328FGK		TC72268	N/A	H228
Fusible, Two-Pole, Three-Wire, 240 Vac, NEMA 1					
30	DH221NGK		TH3221	HF221N	H221N
60	DH222NGK		TH3222	HF222N	H222N
100	DH223NGK		TH3223	HF223N	H223N
200	DH224NGK		TH3224	HF224N	H224N
400	DH225NGK		TH3225	HF225N	H225N
600	DH226NGK		TH3226	HF226N	H226N
800	DH227NGK		TC72267 ^①	HF227N	H227N
1200	DH328NGK		TC72268 ^①	HF228N	H228N
Fusible, Three-Pole, Three-Wire, 240 Vac, NEMA 1					
30	DH321FGK		TH4321	N/A	H321N
60	DH322FGK		TH4322	N/A	H322N
100	DH323FGK		TH4323	N/A	H323N
200	DH324FGK		TH4324	N/A	H324N
400	DH325FGK		TH3325	N/A	H325
600	DH326FGK		TH3326	N/A	H326
800	DH327FGK		TC72367	N/A	H327
1200	DH328FGK		TC72368	N/A	H328
Fusible, Three-Pole, Four-Wire, 240 Vac, NEMA 1					
30	DH321NGK		TH4321	HF321N	H321N
60	DH322NGK		TH4322	HF322N	H322N
100	DH323NGK		TH4323	HF323N	H323N
200	DH324NGK		TH4324	HF324N	H324N
400	DH325NGK		TH4325	HF325N	H325N
600	DH326NGK		TH4326	HF326N	H326N
800	DH327NGK		TC72367 ^①	HF327N	H327N
1200	DH328NGK		TC72368 ^①	HF328N	H328N
Fusible, Four-Pole, Four-Wire, 240 Vac, NEMA 1					
30	DH421FGK	N/A		F421	H461 ^②
60	DH422FGK	N/A		F422	H462 ^②
100	DH423FGK	N/A		F423	H463 ^②
200	DH424FGK	N/A		F424	H464 ^②
400	DH425FGK	N/A		F425	H465 ^②
600	DH426FGK	N/A		F426	H466 ^②

Heavy-Duty, continued

Ampere Rating	Catalog Number		General Electric	Siemens	Square D
	Eaton				
Non-Fusible, Three-Pole, Three-Wire, 240 Volt/600 Vac, NEMA 1					
30	DH361UGK		THN3361	HNF361	HU361
60	DH362UGK		THN3362	HNF362	HU362
100	DH363UGK		THN3363	HNF363	HU363
200	DH364UGK		THN3364	HNF364	HU364
400	DH365UGK		THN3365	HNF365	HU365
600	DH366UGK		THN3366	HNF366	HU366
800	DH367UGK		TC36367	HNF367	HU367
1200	DH368UGK		TC36368	HNF368	HU368
Fusible, Three-Pole, Two-Wire, 240 Vac, NEMA 3R					
30	DH221NRK		TH3221R	N/A	H221NRB
60	DH222NRK		TH3222R	N/A	H222NRB
100	DH223NRK		TH3223R	N/A	H223NRB
200	DH224NRK		TH3224R	N/A	H224NRB
400	DH225FRK		TH3225R	N/A	H225R
600	DH226FRK		TH3226R	N/A	H226R
800	DH227NRK		TC72267R	N/A	H227R
1200	DH328FRK		TC72268R	N/A	H228R
Fusible, Two-Pole, Three-Wire, 240 Vac, NEMA 3R					
30	DH221NRK		TH3221R	HF221NR	H221NRB
60	DH222NRK		TH3222R	HF222NR	H222NRB
100	DH223NRK		TH3223R	HF223NR	H223NRB
200	DH224NRK		TH3224R	HF224NR	H224NRB
400	DH225NRK		TH3225R	HF225NR	H225NR
600	DH226NRK		TH3226R	HF226NR	H226NR
800	DH227NRK		TC72267R ^①	HF227NR	H227NR
1200	DH328NRK		TC72268R ^①	HF228NR	H228NR
Fusible, Three-Pole, Three-Wire, 240 Vac, NEMA 3R					
30	DH321FRK		TH4321R	N/A	H321NRB
60	DH322FRK		TH4322R	N/A	H322NRB
100	DH323FRK		TH4323R	N/A	H323NRB
200	DH324FRK		TH4324R	N/A	H324NRB
400	DH325FRK		TH3325R	N/A	H325NR
600	DH326FRK		TH3326R	N/A	H326NR
800	DH327FRK		TC72367R	N/A	H327NR
1200	DH328FRK		TC72368R	N/A	H328NR

Notes

^① Separate neutral kit required.

^② 600V switch.

Always verify the number of poles and wires required since catalog numbers may appear in multiple tables.

Heavy-Duty, continued

Ampere Rating	Catalog Number Eaton	General Electric	Siemens	Square D
Fusible, Three-Pole, Four-Wire, 240 Vac, NEMA 3R				
30	DH321NRK	TH4321R	HF321NR	H321NRB
60	DH322NRK	TH4322R	HF322NR	H322NRB
100	DH323NRK	TH4323R	HF323NR	H323NRB
200	DH324NRK	TH4324R	HF324NR	H324NRB
400	DH325NRK	TH3325R ①	HF325NR	H325R
600	DH326NRK	TH3326R ①	HF326NR	H326R
800	DH327NRK	TC72367R ①	HF327NR	H327R
1200	DH328NRK	TC72368R ①	HF328NR	H328R
Non-Fusible, Three-Pole, Three-Wire, 240 Volt/600 Vac, NEMA 3R				
30	DH361URK	THN3361R	HNF361R	HU361RB
60	DH362URK	THN3362R	HNF362R	HU362RB
100	DH363URK	THN3363R	HNF363R	HU363RB
200	DH364URK	THN3364R	HNF364R	HU364RB
400	DH365URK	THN3365R	HNF365R	HU365R
600	DH366URK	THN3366R	HNF366R	HU366R
800	DH367URK	N/A	HNF367R	HU367R
1200	DH368URK	N/A	HNF368R	HU368R
Fusible, Two-Pole, Two-Wire, 240 Vac, NEMA 4/4X				
30	DH221NWK	TH2221SS	HF221S	H221DS
60	DH222NWK	TH2222SS	HF222S	H222DS
100	DH223NWK	TH3223SS	HF223S	H223DS
200	DH224NWK	TH3224SS	HF224S	H224DS
400	DH225FWK	TH3225SS	HF325S	H225DS
600	DH226FWK	TH3226SS	HF326S	H226DS
Fusible, Two-Pole, Three-Wire, 240 Vac, NEMA 4/4X				
30	DH221NWK	TH3221SS	HF321S ①	H221DS ①
60	DH222NWK	TH3222SS	HF322S ①	H222DS ①
100	DH223NWK	TH3223SS	HF323S ①	H223DS ①
200	DH224NWK	TH3224SS	HF324S ①	H224DS ①
400	DH225NWK	TH3225SS	HF325S ①	H225NDS
600	DH226NWK	TH3226SS	HF326S ①	H226NDS
800	DH227NWK	N/A	HF327S ①	N/A
Fusible, Three-Pole, Three-Wire, 240 Vac, NEMA 4/4X				
30	DH321FWK	TH3321SS	HF321S	H321DS
60	DH322FWK	TH3322SS	HF322S	H322DS
100	DH323NWK	TH4323SS	HF323S	H323DS
200	DH324NWK	TH4324SS	HF324S	H324DS
400	DH325FWK	TH4325SS	HF325S	H325DS
600	DH326FWK	TH4326SS	HF326S	H326DS
800	DH327FWK	N/A	HF327S	N/A
Fusible, Three-Pole, Four-Wire, 240 Vac, NEMA 4/4X				
30	DH321NWK	TH4321SS	HF321S ①	H321DS ①
60	DH322NWK	TH4322SS	HF322S ①	H322DS ①
100	DH323NWK	TH4323SS	HF323S ①	H323DS ①
200	DH324NWK	TH4324SS	HF324S ①	H324DS ①
400	DH325NWK	TH4325SS	HF325S ①	H325NDS
600	DH326NWK	TH4326SS	HF326S ①	H326NDS

Heavy-Duty, continued

Ampere Rating	Catalog Number Eaton	General Electric	Siemens	Square D
Fusible, Two-Pole, Two-Wire, 240 Vac, NEMA 12				
30	DH221NDK	TH2221J	HF221J	H221AWK
60	DH222NDK	TH2222J	HF222J	H222AWK
100	DH223NDK	TH3223J	HF223J	H223AWK
200	DH224NDK	TH3224J	HF224J	H224AWK
400	DH225FDK	TH3225J	HF325J	H225AWK
600	DH226FDK	TH3226J	HF326J	H226AWK
800	DH227FDK	N/A	HF327J	H227AWK
1200	N/A	N/A	N/A	H228AWK
Fusible, Two-Pole, Three-Wire, 240 Vac, NEMA 12				
30	DH221NDK	TH3221J	HF221J ①	H221AWK
60	DH222NDK	TH3222J	HF222J ①	H222AWK
100	DH223NDK	TH3223J	HF223J ①	H223AWK
200	DH224NDK	TH3224J	HF224J ①	H224AWK
400	DH225NDK	TH3225J	HF325J ①	H225NAWK
600	DH226NDK	TH3226J	HF326J ①	H226NAWK
800	DH227NDK	N/A	HF327J ①	H227NAWK
1200	N/A	N/A	N/A	H228NAWK
Fusible, Three-Pole, Three-Wire, 240 Vac, NEMA 12				
30	DH321FDK	TH3321J	HF321J	H321AWK
60	DH322FDK	TH3322J	HF322J	H322AWK
100	DH323FDK	TH4323J	HF323J	H323AWK
200	DH324FDK	TH4324J	HF324J	H324AWK
400	DH325FDK	TH4325J	HF325J	H325AWK
600	DH326FDK	TH4326J	HF326J	H326AWK
800	DH327FDK	N/A	HF327J	H327AWK
1200	N/A	N/A	N/A	H328AWK
Fusible, Three-Pole, Four-Wire, 240 Vac, NEMA 12				
30	DH321NDK	TH4321J	HF321J ①	H321AWK ①
60	DH322NDK	TH4322J	HF322J ①	H322AWK ①
100	DH323NDK	TH4323J	HF323J ①	H323AWK ①
200	DH324NDK	TH4324J	HF324J ①	H324AWK ①
400	DH325NDK	TH4325J	HF325J ①	H325NAWK
600	DH326NDK	TH4326J	HF326J ①	H326NAWK
800	N/A	N/A	HF327J ①	H327NAWK
1200	N/A	N/A	N/A	H328NAWK
Fusible, Four-Pole, Four-Wire, 240 Vac, NEMA 12				
30	DH421FDK	N/A	N/A	N/A
60	DH422FDK	N/A	N/A	N/A
100	DH423FDK	N/A	N/A	N/A
200	DH424FDK	N/A	N/A	N/A

Notes

① Separate neutral kit required.

Always verify the number of poles and wires required since catalog numbers may appear in multiple tables.

Heavy-Duty, continued

Ampere Rating	Catalog Number Eaton	General Electric	Siemens	Square D
Fusible, Two-Pole, Two-Wire, 600 Vac, NEMA 1				
30	DH261FGK	TH2261DC	HF261	H361
60	DH262FGK	TH2262DC	HF262	H362
100	DH263FGK	TH2263DC	HF263	H363
200	DH264FGK	N/A	N/A	H364
400	DH265FGK	N/A	HF265	H265
600	DH266FGK	N/A	HF266	H266
800	DH267FGK	N/A	N/A	H267
1200	N/A	N/A	N/A	H268
Fusible, Three-Pole, Three-Wire, 600 Vac, NEMA 1				
30	DH361FGK	TH3361	HF361	H361
60	DH362FGK	TH3362	HF362	H362
100	DH363FGK	TH3363	HF363	H363
200	DH364FGK	TH3364	HF364	H364
400	DH365FGK	TH3365	HF365	H365
600	DH366FGK	TH3366	HF366	H366
800	DH367FGK	TC72367	HF367	H367
1200	DH368FGK	TC72368	HF368	H368
Fusible, Three-Pole, Four-Wire, 600 Vac, NEMA 1				
30	DH361NGK	TH3361 ①	HF361N	H361N
60	DH362NGK	TH3362 ①	HF362N	H362N
100	DH363NGK	TH3363 ①	HF363N	H363N
200	DH364NGK	TH3364 ①	HF364N	H364N
400	DH365NGK	TH3365 ①	HF365N	H365N
600	DH366NGK	TH3366 ①	HF366N	H366N
800	DH367NGK	TC72367 ①	HF367N	H367N
1200	DH368NGK	TC72368 ①	HF368 ①	H368N
Fusible, Four-Pole, Four-Wire, 600 Vac, NEMA 1				
30	DH461FGK	TH6661	N/A	H461
60	DH462FGK	TH6662	N/A	H462
100	DH463FGK	TH6663	N/A	H463
200	DH464FGK	TH6664	N/A	H464
400	DH465FGK	N/A	N/A	H465
600	DH466FGK	N/A	N/A	H466
Non-Fusible, Two-Pole, Two-Wire, 600 Vac, NEMA 1				
30	DH261UGK	THN2261DC	HN261	HU361
60	DH362UGK	THN2262DC	HN262	HU362
100	DH263UGK	THN2263DC	HN263	HU363
200	DH364UGK	N/A	N/A	HU364
400	DH265UGK	N/A	HN265	HU265
600	DH266UGK	N/A	HN266	HU266
800	DH267UGK	N/A	N/A	HU267
1200	N/A	N/A	N/A	HU268

Heavy-Duty, continued

Ampere Rating	Catalog Number Eaton	General Electric	Siemens	Square D
Non-Fusible, Four-Pole, Four-Wire, 600 Vac, NEMA 1				
30	DH461UGK	THN6661	N/A	HU461
60	DH462UGK	THN6662	N/A	HU462
100	DH463UGK	THN6663	N/A	HU463
200	DH464UGK	THN6664	N/A	HU464
400	DH465UGK	N/A	N/A	HU465
600	DH466UGK	N/A	N/A	HU466
Fusible, Two-Pole, Two-Wire, 600 Vac, NEMA 3R				
30	DH361FRK	TH2261RDC	HF261R	H361RB
60	DH362FRK	TH2262RDC	HF262R	H362RB
100	DH363FRK	TH2263RDC	HF263R	H363RB
200	DH364FRK	N/A	N/A	H364RB
400	DH365FRK	N/A	N/A	H265R
600	DH366FRK	N/A	HF265R	H266R
800	DH367FRK	N/A	HF266R	H267R
1200	DH368FRK	N/A	N/A	H268R
Fusible, Three-Pole, Three-Wire, 600 Vac, NEMA 3R				
30	DH361FRK	TH3361R	HF361R	H361RB
60	DH362FRK	TH3362R	HF362R	H362RB
100	DH363FRK	TH3363R	HF363R	H363RB
200	DH364FRK	TH3364R	HF364R	H364RB
400	DH365FRK	TH3365R	HF365R	H365R
600	DH366FRK	TH3366R	HF366R	H366R
800	DH367FRK	TC72367R	HF367R	H367R
1200	DH368FRK	TC72368R	HF368R	H368R
Fusible, Three-Pole, Four-Wire, 600 Vac, NEMA 3R				
30	DH361NRK	TH3361R ①	HF361NR	H361NRB
60	DH362NRK	TH3362R ①	HF362NR	H362NRB
100	DH363NRK	TH3363R ①	HF363NR	H363NRB
200	DH364NRK	TH3364R ①	HF364NR	H364NRB
400	DH365NRK	TH3365R ①	HF365NR	H365NR
600	DH366NRK	TH3366R ①	HF366NR	H366NR
800	DH367NRK	TC72367R ①	HF367NR	H367NR
1200	DH368NRK	TC72368R ①	HF368R	H368NR
Non-Fusible, Three-Pole, Three-Wire, 600 Vac, NEMA 3R				
30	DH361URK	THN2261RDC	HN261R	HU361RB
60	DH362URK	THN2262RDC	HN262R	HU362RB
100	DH363URK	THN2263RDC	HN263R	HU363RB
200	DH364URK	N/A	N/A	HU364RB
400	DH365URK	N/A	HN265R	HU265R
600	DH366URK	N/A	HN266R	HU266R
800	DH367URK	N/A	N/A	HU267R
1200	DH368URK	N/A	N/A	HU268R

Notes

① Separate neutral kit required.

Always verify the number of poles and wires required since catalog numbers may appear in multiple tables.

Heavy-Duty, continued

Ampere Rating	Catalog Number Eaton	General Electric	Siemens	Square D
Non-Fusible, Four-Pole, Four-Wire, 600 Vac, NEMA 3R				
30	DH461UDK	THN6661	N/A	N/A
60	DH462UDK	THN6662	N/A	N/A
100	DH463UDK	THN6663	N/A	N/A
200	DH464UDK	THN6664	N/A	N/A
Fusible, Two-Pole, Two-Wire, 600 Vac, NEMA 4/4X Stainless Steel				
30	DH261FWK	TH2261SSDC	HF261S	H361DS
60	DH362FWK	TH2262SSDC	HF262S	H362DS
100	DH363FWK	TH2263SSDC	HF263S	H363DS
200	DH264FWK	N/A	N/A	H364DS
400	DH365FWK	N/A	HF265S	H265DS
600	DH366FWK	N/A	HF266S	H266DS
800	DH367FWK	N/A	N/A	N/A
Fusible, Three-Pole, Three-Wire, 600 Vac, NEMA 4/4X Stainless Steel				
30	DH361FWK	TH3361SS	HF361S	H361DS
60	DH362FWK	TH3362SS	HF362S	H362DS
100	DH363FWK	TH3363SS	HF363S	H363DS
200	DH364FWK	TH3364SS	HF364S	H364DS
400	DH365FWK	TH3365SS	HF365S	H365DS
600	DH366FWK	TH3366SS	HF366S	H366DS
800	DH367FWK	N/A	HF367S	N/A
Fusible, Three-Pole, Four-Wire, 600 Vac, NEMA 4/4X Stainless Steel				
30	DH361NWK	TH3361SS ①	HF361S ①	H361DS ①
60	DH362NWK	TH3362SS ①	HF362S ①	H362DS ①
100	DH363NWK	TH3363SS ①	HF363S ①	H363DS ①
200	DH364NWK	TH3364SS ①	HF364S ①	H364NDS
400	DH365NWK	TH3365SS ①	HF365S ①	H365NDS
600	DH366NWK	TH3366SS ①	HF366S ①	H366NDS
Non-Fusible, Two-Pole, Two-Wire, 600 Vac, NEMA 4/4X Stainless Steel				
30	DH361UWK	THN2261SSDC	HNF261S	HU361DS
60	DH362UWK	THN2262SSDC	HNF262S	HU362DS
100	DH363UWK	THN2263SSDC	HNF263S	HU363DS
200	DH364UWK	N/A	N/A	HU364DS
400	DH365UWK	N/A	HNF265S	HU265DS
600	DH366UWK	N/A	HNF266S	HU266DS
800	DH367UWK	N/A	N/A	N/A
Non-Fusible, Three-Pole, Three-Wire, 600 Vac, NEMA 4/4X Stainless Steel				
30	DH361UWK	THN3361SS	HNF361S	HU361DS
60	DH362UWK	THN3362SS	HNF362S	HU362DS
100	DH363UWK	THN3363SS	HNF363S	HU363DS
200	DH364UWK	THN3364SS	HNF364S	HU364DS
400	DH365UWK	THN3365SS	HNF365S	HU365DS
600	DH366UWK	THN3366SS	HNF366S	HU366DS
800	DH367UWK	N/A	HNF367S	N/A

Heavy-Duty, continued

Ampere Rating	Catalog Number Eaton	General Electric	Siemens	Square D
Non-Fusible, Four-Pole, Four-Wire, 600 Vac, NEMA 4/4X Stainless Steel				
30	DH461UWK	N/A	N/A	HU461DS
60	N/A	N/A	N/A	HU462DS
100	N/A	N/A	N/A	HU464DS
200	N/A	N/A	N/A	HU464DS
Fusible, Two-Pole, Two-Wire, 600 Vac, NEMA 12				
30	DH261FDK	TH2261JDC	HF261J	H361AWK
60	DH262FDK	TH2262JDC	HF262J	H362AWK
100	DH263FDK	TH2263JDC	HF263J	H363AWK
200	DH264FDK	N/A	N/A	H364AWK
400	DH265FDK	N/A	HF265J	H265AWK
600	DH266FDK	N/A	HF266J	H266AWK
800	DH267FDK	N/A	N/A	H267AWK
1200	N/A	N/A	N/A	H268AWK
Fusible, Three-Pole, Three-Wire, 600 Vac, NEMA 12				
30	DH361FDK	TH3361J	HF361J	H361AWK
60	DH362FDK	TH3362J	HF362J	H362AWK
100	DH363FDK	TH3363J	HF363J	H363AWK
200	DH364FDK	TH3364J	HF364J	H364AWK
400	DH365FDK	TH3365J	HF365J	H365AWK
600	DH366FDK	TH3366J	HF366J	H366AWK
800	DH367FDK	N/A	HF367J	H367AWK
1200	N/A	N/A	N/A	H368AWK
Fusible, Three-Pole, Four-Wire, 600 Vac, NEMA 12				
30	DH361NDK	THN3361J ①	HF361J ①	H361AWK ①
60	DH362NDK	THN3362J ①	HF362J ①	H362AWK ①
100	DH363NDK	THN3363J ①	HF363J ①	H363AWK ①
200	DH364NDK	THN3364J ①	HF364J ①	H364NAWK
400	DH365NDK	THN3365J ①	HF365J ①	H365NAWK
600	DH366NDK	THN3366J ①	HF366J ①	H366NAWK
800	DH367NDK	N/A	HF367J ①	H367NAWK
1200	N/A	N/A	N/A	H368NAWK
Fusible, Four-Pole, Four-Wire, 600 Vac, NEMA 12				
30	N/A	TH6661	N/A	H461AWK
60	N/A	TH6662	N/A	H462AWK
100	DH463FDK	TH6663	N/A	H463AWK
200	DH464FDK	TH6664	N/A	H464AWK
400	N/A	N/A	N/A	H465AWK

Notes

① Separate neutral kit required.

Always verify the number of poles and wires required since catalog numbers may appear in multiple tables.

Heavy-Duty, continued

Ampere Rating	Catalog Number Eaton	General Electric	Siemens	Square D
Non-Fusible, Two-Pole, Two-Wire, 600 Vac, NEMA 12				
30	DH261UDK	THN2261JDC	HNF261J	HU361AWK
60	DH262UDK	THN2262JDC	HNF262J	HU362AWK
100	DH263UDK	THN2263JDC	HNF263J	HU363AWK
200	DH264UDK	N/A	N/A	HU364AWK
400	DH265UDK	N/A	HNF265J	HU265AWK
600	DH266UDK	N/A	HNF266J	HU266AWK
800	DH267UDK	N/A	N/A	HU267AWK
1200	N/A	N/A	N/A	HU268AWK
Non-Fusible, Three-Pole, Three-Wire, 600 Vac, NEMA 12				
30	DH361UDK	THN3361J	HNF361J	HU361AWK
60	DH362UDK	THN3362J	HNF362J	HU362AWK
100	DH363UDK	THN3363J	HNF363J	HU363AWK
200	DH364UDK	THN3364J	HNF364J	HU364AWK
400	DH365UDK	THN3365J	HNF365J	HU365AWK
600	DH366UDK	THN3366J	HNF366J	HU366AWK
800	DH367UDK	N/A	HNF367J	HU367AWK
1200	N/A	N/A	N/A	HU368AWK
Non-Fusible, Four-Pole, Four-Wire, 600 Vac, NEMA 12				
30	DH461UDK	THN6661	N/A	HU461AWK
60	DH462UDK	THN6662	N/A	HU462AWK
100	DH463UDK	THN6663	N/A	HU463AWK
200	DH464UDK	THN6664	N/A	HU464AWK
400	N/A	N/A	N/A	HU465AWK

Heavy-Duty Six-Pole

Ampere Rating	Catalog Number Eaton	General Electric	Siemens	Square D
Fusible, Six-Pole, Six-Wire, 600 Vac, NEMA 3R				
30	DH661FDK	TH6661	F651H	N/A
60	DH662FDK	TH6662	F652H	N/A
100	DH663FDK	TH6663	F653H	N/A
200	DH664FDK	TH6664	N/A	N/A
Fusible, Six-Pole, Six-Wire, 600 Vac, NEMA 12				
30	DH661FDK	TH6661	F651H	N/A
60	DH662FDK	TH6662	F652H	N/A
100	DH663FDK	TH6663	F653H	H663AWK
200	DH664FDK	TH6664	N/A	H664RWK
Fusible, Six-Pole, Six-Wire, 600 Vac, NEMA 4X				
30	N/A	N/A	F651SS	N/A
60	N/A	N/A	F652SS	N/A
100	N/A	N/A	F653SS	H663DS
200	N/A	N/A	N/A	H664DS
Non-Fusible, Six-Pole, Six-Wire, 600 Vac, NEMA 3R				
30	DH661UDK	THN6661	NF651H	N/A
60	DH662UDK	THN6662	NF652H	N/A
100	DH663UDK	THN6663	NF653H	N/A
200	DH664UDK	THN6664	N/A	N/A
Non-Fusible, Six-Pole, Six-Wire, 600 Vac, NEMA 12				
30	DH661UDK	THN6661	NF651H	HU661AWK
60	DH662UDK	THN6662	NF652H	HU662AWK
100	DH663UDK	THN6663	NF653H	HU663AWK
200	DH664UDK	THN6664	N/A	HU664RWK
Non-Fusible, Six-Pole, Six-Wire, 600 Vac, NEMA 4X				
30	DH661UWK	N/A	NF651SS	HU661DS
60	DH662UWK	N/A	NF652SS	HU662DS
100	DH663UWK	N/A	NF653SS	HU663DS
200	DH664UWK	N/A	N/A	HU664DS

Note

Always verify the number of poles and wires required since catalog numbers may appear in multiple tables.

Double-Throw

Ampere Rating	Eaton Catalog Number	General Electric	Siemens	Square D
Fusible, Two-Pole, Two-Wire, 240 Vac, NEMA 1				
30	DT321FGK	TDT3321	N/A	N/A
60	DT322FGK	TDT3322	N/A	N/A
100	DT323FGK	TDT3323	N/A	DT223
200	DT224FGK	TDT3324	DTF224	DT224
400	DT325FGK	TDT3325	N/A	N/A
600	DT326FGK	TDT3326	N/A	N/A
Fusible, Three-Pole, Three-Wire, 240 Vac, NEMA 1				
30	DT321FGK	TDT3321	DTF321	DT321
60	DT322FGK	TDT3322	DTF322	DT322
100	DT323FGK	TDT3323	DTF323	DT323
200	DT324FGK	TDT3324	DTF324	DT324
400	DT325FGK	TDT3325	DTF325	N/A
600	DT326FGK	TDT3326	DTF326	N/A
Non-Fusible, Two-Pole, Two-Wire, 240 Vac, NEMA 1				
30	DT221UGK	N/A	DTNF221	92251
60	DT222UGK	N/A	DTNF222	DTU222
100	DT223UGK	N/A	DTNF223	DTU223
200	DT224UGK	N/A	DTNF224	DTU224
400	DT225UGK	N/A	DTNF225	92255
600	DT226UGK	N/A	DTNF226	N/A
800	DT227UGK	N/A	N/A	N/A
Non-Fusible, Three-Pole, Three-Wire, 240 Vac, NEMA 1				
30	DT321UGK	TC35321	DTNF321	DTU321
60	DT322UGK	TC35322	DTNF322	DTU322
100	DT323UGK	TC35323	DTNF323	DTU323
200	DT324UGK	TC35324	DTNF324	DTU324
400	DT325UGK	TC35325	DTNF325	92355
600	DT326UGK	TC35326	DTNF326	92356
800	DT327UGK	N/A	DTNF327	N/A
Fusible, Three-Pole, Three-Wire, 600 Vac, NEMA 1				
30	DT361FGK	TDT3361	DTF361	DT361
60	DT362FGK	TDT3362	DTF362	DT362
100	DT363FGK	TDT3363	DTF363	DT363
200	DT364FGK	TDT3364	DTF364	DT364
400	DT365FGK	TDT3365	DTF365	N/A
600	N/A	N/A	N/A	N/A
Non-Fusible, Two-Pole, Two-Wire, 600 Vac, NEMA 1				
30	DT261UGK	N/A	DTNF261	N/A
60	DT262UGK	N/A	DTNF262	82342
100	DT263UGK	N/A	DTNF263	82343
200	DT264UGK	N/A	DTNF264	82344
400	DT265UGK	N/A	DTNF265	92345
600	DT266UGK	N/A	DTNF266	92346

Double-Throw, continued

Ampere Rating	Eaton Catalog Number	General Electric	Siemens	Square D
Non-Fusible, Three-Pole, Three-Wire, 600 Vac, NEMA 1				
30	DT361UGK	TC35361	DTNF361	DTU361
60	DT362UGK	TC35362	DTNF362	DTU362
100	DT363UGK	TC35363	DTNF363	DTU363
200	DT364UGK	TC35364	DTNF364	DTU364
400	DT365UGK	TC35365	DTNF365	92345
600	DT366UGK	TC35366	DTNF366	92346
800	DT367UGK	N/A	DTNF367	N/A
1200	N/A	N/A	N/A	N/A
Non-Fusible, Four-Pole, Four-Wire, 600 Vac, NEMA 1				
30	N/A	N/A	N/A	N/A
60	N/A	N/A	N/A	DTU462
100	N/A	N/A	N/A	DTU463
200	DT464UGK	N/A	NF454DTK	DTU464
400	DT465UGK	N/A	NF455DTK	92445
600	DT466UGK	N/A	NF456DTK	92446
800	DT467UGK	N/A	NF457DTK	N/A
Fusible, Two-Pole, Two-Wire, 240 Vac, NEMA 3R				
30	DT321FRK	TDT3321R	N/A	N/A
60	DT322FRK	TDT3322R	N/A	N/A
100	DT323FRK	TDT3323R	N/A	DT223RB
200	DT224FRK	TDT3324R	DTF224R	DT224RB
Fusible, Three-Pole, Three-Wire, 240 Vac, NEMA 3R				
30	DT321FRK	TDT3321R	DTF321R	DT321RB
60	DT322FRK	TDT3322R	DTF322R	DT322RB
100	DT323FRK	TDT3323R	DTF323R	DT323RB
200	DT324FRK	TDT3324R	DTF324R	DT324RB
400	DT325FRK	N/A	FR325DTK	N/A
600	DT326FRK	N/A	FR326DTK	N/A
Non-Fusible, Two-Pole, Two-Wire, 240 Vac, NEMA 3R				
30	N/A	N/A	N/A	N/A
60	N/A	N/A	N/A	N/A
100	DT223URK	N/A	N/A	DTU223RB
200	DT224URK	N/A	DTNF224R	DTU224RB
400	DT225URK	N/A	DTNF225R	92255R
Non-Fusible, Three-Pole, Three-Wire, 240 Vac, NEMA 3R				
30	N/A	N/A	N/A	N/A
60	N/A	N/A	N/A	N/A
100	DT323URK	N/A	DTNF323R	DTU323RB
200	DT324URK	N/A	DTNF324R	DTU324RB
400	DT325URK	N/A	N/A	92355R
600	N/A	N/A	N/A	92356R

Note

Always verify the number of poles and wires required since catalog numbers may appear in multiple tables.

Double-Throw, continued

Ampere Rating	Catalog Number Eaton	General Electric	Siemens	Square D
Fusible, Three-Pole, Three-Wire, 600 Vac, NEMA 3R				
30	N/A	N/A	N/A	DT361RB
60	N/A	N/A	N/A	DT362RB
100	DT363FRK	N/A	DTF363R	DT363RB
200	DT364FRK	N/A	DTF364R	DT364RB
400	DT365FRK	N/A	FR355DTK	N/A
Non-Fusible, Two-Pole, Two-Wire, 600 Vac, NEMA 3R				
30	N/A	N/A	N/A	N/A
60	N/A	N/A	N/A	82342RB
100	N/A	N/A	N/A	82343RB
200	DT264URK	N/A	DTNF264R	82344RB
400	DT265URK	N/A	DTNF265R	92345RB
600	DT266URK	N/A	NFR256DTK	92346RB
Non-Fusible, Three-Pole, Three-Wire, 600 Vac, NEMA 3R				
30	DT361URK	N/A	DTNF361R	DTU361RB
60	DT362URK	N/A	DTNF362R	DTU362RB
100	DT363URK	N/A	DTNF363R	DTU363RB
200	DT364URK	N/A	DTNF364R	DTU364RB
400	DT365URK	N/A	DTNF365R	92345RB
600	DT366URK	N/A	DTNF366R	92346RB
800	DT367URK	N/A	DTNF367R	N/A
Non-Fusible, Four-Pole, Four-Wire, 600 Vac, NEMA 3R				
30	DT461URK	N/A	NFR451DTK	N/A
60	DT462URK	N/A	NFR452DTK	92442RB
100	DT463URK	N/A	NFR453DTK	92443RB
200	DT464URK	N/A	NFR454DTK	92444RB
400	DT465URK	N/A	NFR455DTK	92445R
600	DT466URK	N/A	NFR456DTK	92446R
800	DT467URK	N/A	NFR457DTK	N/A
Non-Fusible, Six-Pole, Six-Wire, 600 Vac, NEMA 3R				
30	DT661URK	N/A	NFR651DTK	N/A
60	DT662URK	N/A	NFR652DTK	N/A
100	DT663URK	N/A	NFR653DTK	N/A
Non-Fusible, Two-Pole, Two-Wire, 240 Vac, NEMA 12 ^①				
30	DT361UDK	N/A	DTNF361J	H92251
60	DT362UDK	N/A	DTNF362J	H82252
100	DT363UDK	N/A	DTNF363J	H82253
200	DT364UDK	N/A	DTNF364J	H82254
400	DT365UDK	N/A	NF355HDTK	H92255
Non-Fusible, Three-Pole, Three-Wire, 240 Vac, NEMA 12 ^①				
30	DT361UDK	N/A	DTNF361J	H92351
60	DT362UDK	N/A	DTNF362J	DTU362AWK
100	DT363UDK	N/A	DTNF363J	DTU363AWK
200	DT364UDK	N/A	DTNF364J	DTU364AWK
400	DT365UDK	N/A	NF355HDTK	H92355
600	N/A	N/A	N/A	H92356
Non-Fusible, Four-Pole, Four-Wire, 240 Vac, NEMA 12				
30	N/A	N/A	N/A	H92451
60	N/A	N/A	N/A	DTU462AWK
100	N/A	N/A	N/A	DTU463AWK
200	N/A	N/A	N/A	DTU464AWK
400	N/A	N/A	N/A	H92455
600	N/A	N/A	N/A	H92456

Double-Throw, continued

Ampere Rating	Catalog Number Eaton	General Electric	Siemens	Square D
Non-Fusible, Two-Pole, Two-Wire, 600 Vac, NEMA 12				
30	DT361UDK	N/A	DTNF361J	N/A
60	DT362UDK	N/A	DTNF362J	H82342
100	DT363UDK	N/A	DTNF363J	H82343
200	DT364UDK	N/A	DTNF364J	H82344
400	DT365UDK	N/A	NF355HDTK	H92345
600	N/A	N/A	N/A	H92346
Non-Fusible, Three-Pole, Three-Wire, 600 Vac, NEMA 12				
30	DT361UDK	N/A	DTNF361J	N/A
60	DT362UDK	N/A	DTNF362J	DTU362AWK
100	DT363UDK	N/A	DTNF363J	DTU363AWK
200	DT364UDK	N/A	DTNF364J	DTU364AWK
400	DT365UDK	N/A	NF355HDTK	H92345
600	N/A	N/A	N/A	H92346
Non-Fusible, Four-Pole, Four-Wire, 600 Vac, NEMA 12				
30	N/A	N/A	N/A	N/A
60	N/A	N/A	N/A	DTU462AWK
100	N/A	N/A	N/A	DTU463AWK
200	N/A	N/A	N/A	DTU464AWK
400	N/A	N/A	N/A	H92445
600	N/A	N/A	N/A	H92446
Non-Fusible, Two-Pole, Two-Wire, 600 Vac, NEMA 4X				
30	DT361UWK	N/A	DTNF361S	N/A
60	DT362UWK	N/A	DTNF362S	82342DS
100	DT363UWK	N/A	DTNF363S	82343DS
200	DT364UWK	N/A	DTNF364S	82344DS
400	DT365UWK	N/A	NF355SSDTK	N/A
Non-Fusible, Three-Pole, Three-Wire, 600 Vac, NEMA 4X				
30	DT361UWK	N/A	DTNF361S	N/A
60	DT362UWK	N/A	DTNF362S	DTU362DS
100	DT363UWK	N/A	DTNF363S	DTU363DS
200	DT364UWK	N/A	DTNF364S	DTU364DS
400	DT365UWK	N/A	NF355SSDTK	N/A
Non-Fusible, Four-Pole, Four-Wire, 600 Vac, NEMA 4X				
30	N/A	N/A	N/A	N/A
60	N/A	N/A	N/A	DTU462DS
100	N/A	N/A	N/A	DTU463DS
200	N/A	N/A	N/A	DTU464DS
Fusible, Three-Pole, Three-Wire, 600 Vac, NEMA 4X				
30	DT361FWK	N/A	F351SSDTK	N/A
60	DT362FWK	N/A	F352SSDTK	N/A
100	DT363FWK	N/A	F353SSDTK	N/A
200	DT364FWK	N/A	F354SSDTK	N/A
400	DT365FWK	N/A	F355SSDTK	N/A

Notes

^① Eaton and Siemens switches shown are 600V switches.

Always verify the number of poles and wires required since catalog numbers may appear in multiple tables.

Catalog Number Selection

General-Duty

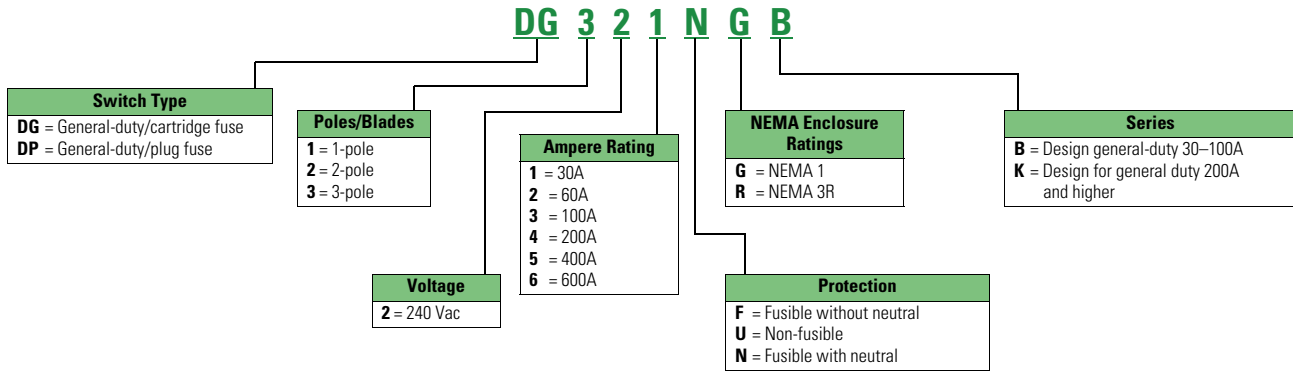

Heavy-Duty

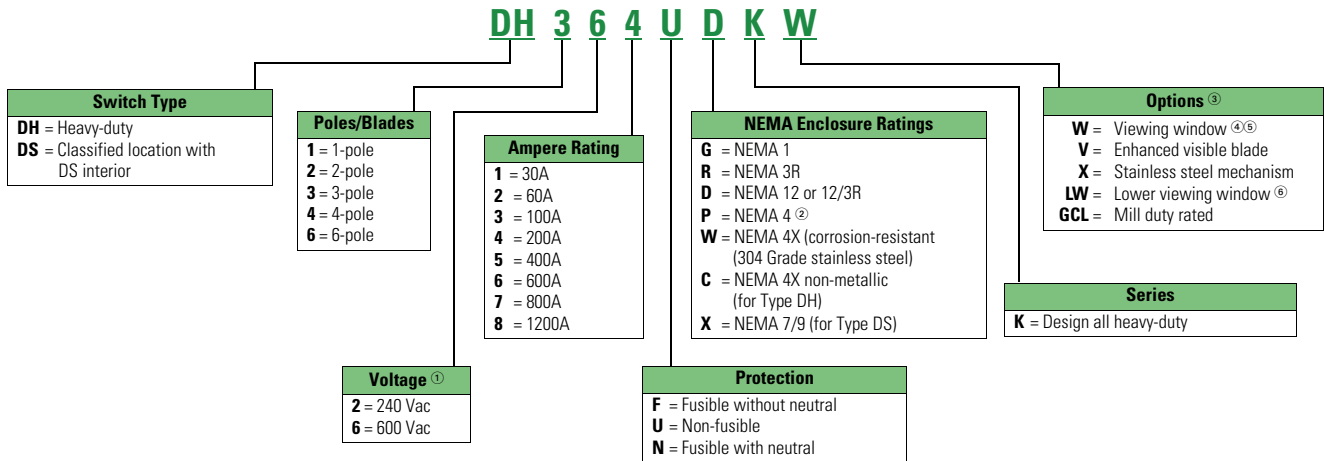

Notes

- ① For DC ratings, check individual switch ratings.
- ② Only available for 400A and higher safety switches.
- ③ See Modifications-Flex Center for additional available options.
- ④ All window switches feature enhanced visible blade design as standard.
- ⑤ Only available in NEMA 12/3R and NEMA 4X enclosures.
- ⑥ Only available in 200 to 1200A NEMA 12/3R and NEMA 4X enclosures.

These tables are intended for use in breaking down existing catalog numbers. They are not intended for building new catalog numbers.

A factory-installed ground lug is supplied in all heavy-duty safety switches.

Double-Throw

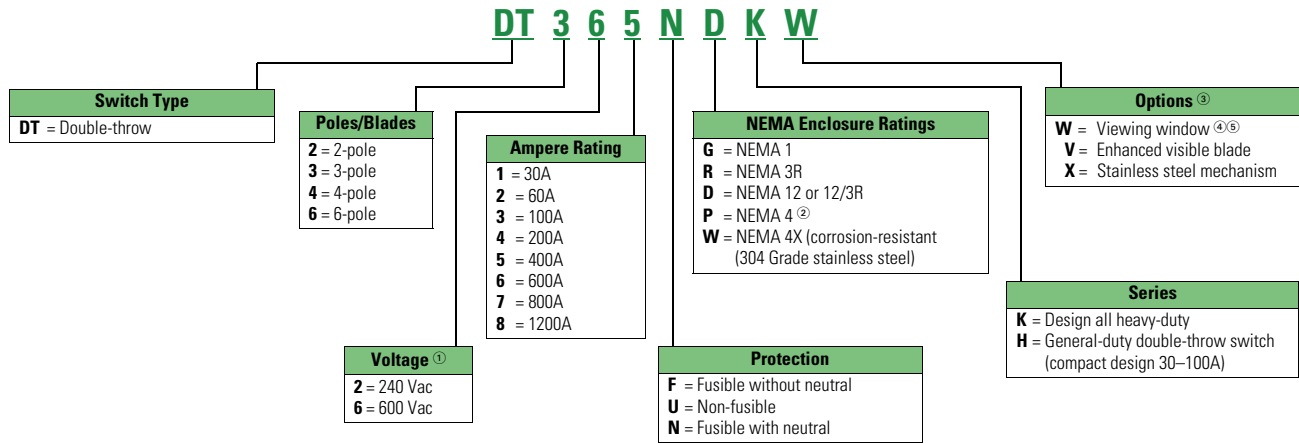

Notes







- ① For DC ratings, check individual switch ratings.
- ② Only available for 400A and higher safety switches.
- ③ See Modifications-Flex Center for additional available options.
- ④ All window switches feature enhanced visible blade design as standard.
- ⑤ Only available in NEMA 12/3R and NEMA 4X enclosures.

These tables are intended for use in breaking down existing catalog numbers. They are not intended for building new catalog numbers.

A factory-installed ground lug is supplied in all heavy-duty safety switches.

Options and Accessories

Safety Switches

	Description	Catalog Number
	Neutral Kits	
	30A DG	DG030NB
	60–100A DG	DG100NB
	200A DG, DH (NEMA 1, 3R enclosures)	DG200NK
	30–60A DH	DH030NK
	100A DH	DH100NK
	200A DH (NEMA 4X, 12 enclosures)	DH200NK
	400A DG, DH	DS400NK
	600A DG, DH	DS600NK
	400A fusible DT, 800–1200A DH	DS800NK
	30–100A DT	DT100NK
	200A DT	DT200NK
	400A non-fusible DT	DT400NK
	600A non-fusible DT	DT600NK
600A fusible DT, 800A DT	DT800NK	
1200A DT	DT1200NK	
	Ground Lug Kits Factory-installed ground lug is supplied in all safety switches	
	30–100A DG	DG030GB
	30–100A DH, DT ①	DS100GK
	200A DG, DH, DT	DS200GK
	Switching Neutral Bonding Kits ②	
	30–100A DT, 3P, 4P non-fusible	DT100BK
	200A DT, 3P, 4P non-fusible	DT200BK
	400A DT, 3P, 4P non-fusible	DT400BK
	600A DT, 3P, 4P non-fusible	DT600BK
800–1200A DT, 3P, 4P non-fusible	DT800BK	
	Control Pole Kit (For 2P, 3P Switches)	DS16CP
	400–600A DG, 30–1200A DH, 30–1200A DT Multiple key options are included with the control pole kit. Standard keys provide late-make, early-break functionality. Flanged key provides same make, same break functionality.	
	Auxiliary Contact Kits Auxiliary contact kits are not field installable on shunt trip safety switches	
	All switches (except 30–100A DG) 1NO/1NC	DS200EK1 ③
	All switches (except 30–100A DG) 2NO/2NC	DS200EK2 ③
	NEMA 7/9 switches (30–100A) 1NO/1NC	178C265G05
NEMA 7/9 switches (30–100A) 2NO/2NC	178C265G06	
	Copper Lug Kits	
	30A DH, DT ④	DS16CL
	60A DH, DT ④	DS26CL
	100A DH, DT ④	DS36CL
	200A DH ④	DS46CL
	400A DH (NEMA 4, 4X, 12 enclosures) ⑤	DS56CL
600–800A DH (NEMA 4, 4X, 12 enclosures) ⑤	DS66CL	

Safety Switches, continued

	Description	Catalog Number	
	Crimp Lug Pad Kit (NEMA 4, 4X, 12 Enclosures Only)		
	400–600A DH ④	DS56CK	
	800A DH ⑤	DS76CK	
	400–800A neutral DH ②	DS800CNK	
	Fuse Puller Kits		
	30A DH ④	DS30FP	
	60A DH ④	DS60FP	
	100A DH ④	DS100FP	
200A DH ④	DS200FP		
	"J" Fuse Adapter Kits ⑥⑦		
	60A 240V DH ④	DS22JK	
	60A DH, DT and receptacle switches ④	DS26JK	
	400A 600V DT ⑧	DT400JK	
	600A 240–600V DH, 600A DG ⑤	DS600JK	
	"R" Fuse Adapter Kits ④		
	30A DG	DG030RB	
	100A DG	DG100RB	
	30A 240V DH, DT	DS12FK	
	30A 600V DH, DT, 60A 240V DH, DT, 60A DG	DS16FK	
	60A 600V DH, DT	DS26FK	
	100A 240–600V DH, DT	DS36FK	
	200A 240–600V DH, DT, 200A DG	DS46FK	
	400A 240–600V DH, 240V DT, 400A DG	DS56FK	
	600A 240–600V DH, DT, 600A DG	DS66FK	
		"T" Fuse Adapter Kits	
		200A 240V DH ④	DS426TK
		200A 600V DH ④	DS466TK
400A 240V DG, DH, DT ⑤		DS526TK	
400A 600V DH ⑤		DS566TK	
600A 240V DG, DH ⑤		DS626TK	
600A 600V DH ⑤		DS666TK	
600A 240V ⑤		DT626TK	
600A 600V ⑤		DT666TK	
800A 240V DH ⑤		DS726TK	
800A 600V DH, DT ⑤	DS766TK		
	Miscellaneous Kits		
	Hookstick handle	DH800HSH	
	Lubricating grease for safety switch blades and contacts (each kit contains three 30 cc tubes of lubricating grease)	DSLUBEKIT	

Notes

- ① Ground bar kit is not listed on device publications.
- ② Order one kit per switch.
- ③ For duty ratings, see table on following page.
- ④ Order one kit for three poles.
- ⑤ Order one kit for each pole.
- ⑥ 30A Class J available as factory option only.
- ⑦ If Class J fuse kit is not listed, then switch will accept Class J fusing by repositioning either fuse base or fuse clips. No drilling required.
- ⑧ Order one kit for six poles.

Accessories are not applicable to NEMA 7/9 switches unless indicated otherwise.

Auxiliary Contact Rating**AC Pilot Duty Ratings**

Catalog Number	Description	Volts	Break (Amperes)	Make (Amperes)
DS200EK1	1NO-1NC	110	15.0	40.0
DS200EK1	1NO-1NC	220	10.0	20.0
DS200EK1	1NO-1NC	440	6.0	10.0
DS200EK1	1NO-1NC	600	5.0	8.0
DS200EK2	2NO/2NC	110	3.0	30.0
DS200EK2	2NO/2NC	220	1.5	15.0
DS200EK2	2NO/2NC	440	1.0	8.0
DS200EK2	2NO/2NC	600	0.8	6.0

DC Pilot Duty Ratings

Catalog Number	Description	Volts	Single Throw (Amperes)	Double Throw (Amperes)
DS200EK1	1NO-1NC	115	2.0	0.5
DS200EK1	1NO-1NC	230	0.5	0.2
DS200EK1	1NO-1NC	600	0.1	0.02
DS200EK2	2NO/2NC	115	1.0	0.2
DS200EK2	2NO/2NC	230	0.3	0.1
DS200EK2	2NO/2NC	600	0.1	—

Approximate Dimensions in Inches (mm)

DS050MH**Myers Type Hubs**

NEMA 3R (400A and above)

NEMA 4, 4X (stainless steel), 12

Catalog Number	Conduit Size
DS050MH	0.50 (12.7)
DS075MH	0.75 (19.1)
DS100MH	1.00 (25.4)
DS125MH	1.25 (31.8)
DS150MH	1.50 (38.1)
DS200MH	2.00 (50.8)
DS250MH	2.50 (63.5)
DS300MH	3.00 (76.2)
DS350MH	3.50 (88.9)
DS400MH	4.00 (101.6)
DS500MH	5.00 (127.0)

DS075H1**Plate Type Hubs**

For NEMA 3R enclosures (up to 200A)

Group 1

General-Duty, Heavy-Duty,
Double-Throw Through 100A

Catalog Number	Conduit Size
DS075H1	0.75 (19.1)
DS100H1	1.00 (25.4)
DS125H1	1.25 (31.8)
DS150H1	1.50 (38.1)
DS200H1	2.00 (50.8)

Group 2

General-Duty, Heavy-Duty,
Double-Throw—200A

Catalog Number	Conduit Size
DS200H2	2.00 (50.8)
DS250H2	2.50 (63.5)
DS300H2	3.00 (76.2)
—	—
—	—

Catalog number **DS900AP** adapter kit permits installation of Group 1 hubs on 200A type general-duty, heavy-duty and double-throw switches.

Modifications—Flex Center

Introduction

The Switching Device Flex Center is a special facility at the site of Eaton's Cleveland, Tennessee plant that is dedicated to providing customized safety switches and enclosed breakers that meet customer's challenging applications.

Common Flex Center Design Offerings

Modification	Catalog Suffix	Description
Custom paint	(varies)	Special paint colors are available such as red, orange, yellow, green, black, white. Other colors may be available upon request. Custom color is applied over the standard ANSI-61 gray finish.
Nameplates	-00NP	Plastic or phenolic nameplates are available. Up to three lines of text, 25 characters per line. Standard offering is white with black letters. Custom colors and sizes available upon request. Specify text at order entry.
Lock on provisions	-00LO	Available on heavy-duty and double-throw safety switches. Provision will accept a single lock.
Trapped key interlock	-00TK	Available on heavy-duty and double-throw safety switches. Trapped key systems are used on safety switches to prevent unauthorized operations or to predetermine a series of power transfers by an authorized operator.
Upper viewing window	W	An upper viewing window is centered over the switching contacts to provide visual verification of ON/OFF status. Available on NEMA 12/3R and NEMA 4X stainless steel heavy-duty and double-throw safety switches. Note: 30–100 A switches are now provided with a full view cover window for both blade and blown fuse viewing.
Lower viewing window	LW	A lower viewing window is centered over the fuses and provides visual verification of blown fuse indicators. Available on 200–1200 A NEMA 12/3R and NEMA 4X stainless steel heavy-duty and double-throw safety switches. Available for fusible switches only. Note: 30–100 A switches are now provided with a full view cover window for both blade and blown fuse viewing.
Neutral assemblies	N	Factory install of field neutral accessory kits. Add Suffix N on non-fusible switches, or replace the 6th character "F" with "N" on fusible switches.
Class "R" fuse clips	5 or 6	Factory installed Class R fuse clips/provisions. Add Suffix 5 for 240 V switches, and Suffix 6 for 600 V switches. Available on 30–600 A safety switches.
Class "T" fuse clips	T	Factory installed Class T fuse clips/provisions. Available on 200–1200 A safety switches.
Class "J" fuse clips	J	Factory installed Class J fuse clips/provisions. Available on 30–600 A safety switches. Note: Field modification kits are not available for 30 A heavy-duty safety switches. 30 A switches requiring Class J fusing must be ordered factory installed with J suffix.
Fungus proofing	-00FP	All non-metallic components of the switch are coated with a moisture and fungus-resistant varnish. The inhibitor used meets military specification: MIL-V-173C for MOISTURE AND FUNGUS-RESISTANT TREATMENT. The treated switch meets military specification MIL-T-152E for MOISTURE AND FUNGUS-RESISTANT TREATMENT OF COMMUNICATIONS, ELECTRONICS, AND ASSOCIATED EQUIPMENT. Not UL Listed.
Fuse pullers	FE	Factory installed fuse pullers. Note: Standard NEMA 12/3R and 4X switches 30–200 A are supplied with fuse pullers from the factory.
Crimp lug pads	-00CK	Factory installed crimp lug pad kits. Available on 400–800 A safety switches. Crimp lugs are not included. Note: Standard heavy-duty Type DH switches 30–200 A are adaptable to crimp lugs; simply remove the box lugs.
Copper lugs	-00CL	Factory installed copper lug kits. Available on 30–800 A safety switches.
Ground lug kits factory installed	G	Factory installed ground lug kits. Provides additional ground lug capacity when compared to ground lugs that come with standard safety switches. Available on 30–1200 A safety switches.
Custom lugs	-000L	Customer-specified lug arrangements are available on heavy-duty and double-throw safety switches.
Auxiliary contacts	2 or 3	Factory installed auxiliary contact kits (DS200EK1 or DS200EK2). Auxiliary contacts are Early-Make/Early-Break operation. To specify 1NO/1NC contact, add Suffix 2. To specify 2NO/2NC contacts, add Suffix 3.
Control pole	-00CP	The K-Series control pole provides one NO contact. It mounts in the exact location as the neutral block using the same pre-drilled holes. This is directly connected to the power pole operating shaft. Direct connection and visible blades provide more secure electrical interlocking than handle linkage operation of a snap/switch type interlock. This reliability meets the requirements of many specifications for four-pole switches when the fourth pole is required for secure electrical interlocking. This control pole provides Same-Make/Same-Break operation.
Control pole with offset	-0CP2	Same as above except this control pole provides Late-Make/Early-Break operation. Both Control Pole options are provided when you purchase the DS16CP field kit.
Switching neutral double throws	SN	UL Listed for three-pole and four-pole non-fusible double-throw safety switches. Switching neutrals are required for separately derived systems when bonding the neutral of the generator to a grounding system at the generator.
Surge protection	(varies)	Factory installed Eaton Type 1 (SP1 series) or Type 2 (CVX series) surge protective device products. SPD installed and wired to load side of disconnect.

Additional Flex Center Design Offerings

- Left-hand design (30–200A)
- Cover controls
- 200% neutrals
- Seam-welded stainless steel
- Quick Connect products with Cam-Lok and Posi-Lok receptacles
- Custom enclosures
- 316 grade stainless steel
- Mill duty switches
- Irrigation switches
- Fuses installed
- Hook stick handles (heavy-duty switches only)
- Custom labels
- Custom mounting
- Pad-mount designs
- Non-standard receptacles
- Enhanced visible blade
- Voltage indicators

Contact

For more information on these or any other modifications, please contact the Switching Device Flex Center at 1-888-329-9272, email FlexSwitches@eaton.com or visit Eaton.com/FlexCenter.

Technical Data and Specifications

Standard Lug Capacities

Description	Minimum Wire Size	Maximum Wire Size	Wire Type
30A DP	#14	#10	CU
	#12	#10	AL
30A DG	#14	#6	CU/AL
30A DH, DT	#14	#2	CU/AL
60A DG	#14	#1/0	CU/AL
60A DH, DT	#14	#2	CU/AL
100A DG ^①	#14	#1/0	CU/AL
100A DH, DT	#14	#1/0	CU/AL
200A DG, DT	#6	250 kcmil	CU/AL
200A DH Type 1 and 3R	#6	250 kcmil	CU/AL
200A DH Type 4X and 12	#6	300 kcmil	CU/AL
400A DG, DH, DT ^②	(2) #1/0	(2) 300 kcmil	CU/AL or ^③
	(1) #1/0	(1) 750 kcmil	CU/AL
600A DG, DH	(1) #2	(1) 600 kcmil	CU/AL and ^④
	(1) #1/0	(1) 750 kcmil	CU/AL
600A non-fusible DT	(2) 250	(2) 500 kcmil	CU/AL
800A DH	(4) #1/0	(4) 750 kcmil	CU/AL
600A fusible DT, 800A DT	(3) #250	(3) 500 kcmil	CU/AL
1200A DH, DT	(4) #1/0	(4) 750 kcmil	CU/AL
Copper-Bodied Lugs ^⑤			
30A CU	#14	#6	CU
60A CU	#14	#4	CU
100A CU	#6	#1/0	CU
200A CU	#6	250 kcmil	CU
400A CU Type 4, 4X, and 12	#1/0	500 kcmil	CU
600-800A CU Type 4, 4X and 12	(2) #1/0	(2) 500 kcmil	CU

Notes

- ① The maximum size aluminum or copper-clad wire allowable for applications where the conductor enters or leaves the enclosure through the wall opposite its terminal is #1 gauge.
- ② Applicable to DG/DH non-fused NEMA 1 and 3R only. The maximum size wire allowable for applications where the conductor enters or leaves the enclosure through the wall opposite its terminal is 250 kcmil.
- ③ Single barrel lug that accepts one or two cables per phase as detailed above.
- ④ Double barrel lug that accepts 2 cables per phase as detailed above.
- ⑤ No Copper-Bodied Lugs are available for 1200A switches. No Copper-Bodied Lugs are available for larger than 500 kcmil cables. No Copper-Bodied Lugs are available for 400–800A NEMA 1 or NEMA 3R switches.

Although certain lug capacities are larger than required, only minimum wire bending space is provided per the requirements noted in NEC®. A factory-installed ground lug is supplied in all heavy-duty safety switches.

Alternate Lug Capacities ^①

Description	Minimum Wire Size	Maximum Wire Size	Wire Type	Catalog Number Suffix	Line/Load ^②
30A, 60A, 100A DH fusible	(3) #14	(3) #2	CU/AL	-00LA ^③	
30A, 60A, 100A DH	(3) #14	(3) #2	CU/AL	-LALN ^③	Line lugs only
30A, 60A, 100A DH fusible	(3) #14	(3) #2	CU/AL	-LALD ^③	Load lugs only
30A, 60A, 100A DH fusible	(2) #14	(2) #2/0	CU/AL	-00LB ^③	
30A, 60A, 100A DH	(2) #14	(2) #2/0	CU/AL	-LBLN ^③	Line lugs only
30A, 60A, 100A DH fusible	(2) #14	(2) #2/0	CU/AL	-LBLD ^③	Load lugs only
30A, 60A DH	#14	#1/0	CU/AL	-LSE3 ^④	
100A DH Type 1 and 3R	#6	250 kcmil	CU/AL	-LSE4 ^④	
100A DH Type 4X and 12	#6	300 kcmil	CU/AL	-LSE4 ^④	
200A DH	(2) #1/0	(2) 300 kcmil	CU/AL or ^⑤	-LSE5 ^⑥	
	(1) #1/0	(1) 750 kcmil	CU/AL		
400A DH	(1) #2	(1) 600 kcmil	CU/AL and ^⑦	-LSE6 ^⑧	
	(1) #1/0	(1) 750 kcmil	CU/AL		
600A DH	(4) #1/0	(4) 750 kcmil	CU/AL	-LSE7 ^⑨	

Notes

- ① Alternate Lugs are available as Factory Installed options only, through the Switching Device Flex Center. Field Kits are not available.
- ② The Alternate Lugs will be provided on both Line and Load side, unless otherwise noted.
- ③ Uses the 100A switch enclosure and dimensions.
- ④ Uses the 200A switch enclosure and dimensions.
- ⑤ Single barrel lug that accepts one or two cables per phase as specified in table.
- ⑥ Uses the 400A switch enclosure and dimensions.
- ⑦ Double barrel lug that accepts two cables per phase as specified in table.
- ⑧ Uses the 600A switch enclosure and dimensions.
- ⑨ Uses the 800A switch enclosure and dimensions.

Although certain lug capacities are larger than required, only minimum wire bending space is provided per the requirements noted in NEC[®].

A factory-installed ground lug is supplied in all heavy-duty safety switches.

Standard Ground Lug Capacities

Description	Minimum Wire Size	Maximum Wire Size	Wire Type
30, 60, 100A DG	#14	#4	CU/AL
200A DG	(2) #14	(2) #2	CU/AL
400, 600A DG	(2) #6	(2) 250 kcmil	CU/AL
30, 60, 100A DH	#14	#4	CU/AL
200A DH Type 1 and 3R	(2) #14	(2) #2	CU/AL
200A DH Type 4X and 12	#14	#4	CU/AL
400A, 600A, 800A, 1200A DH	(2) #6	(2) 250 kcmil	CU/AL
30, 60, 100A DT	(3) #14	(3) #2	CU/AL
200A DT	(3) #14	(3) #2	CU/AL
400A DT	(3) #6	(3) 250 kcmil	CU/AL
600A, 800A, 1200A DT	(4) #6	(4) 250 kcmil	CU/AL

Additional Grounding (Suffix G) Lug Capacities ^①

Description	Minimum Wire Size	Maximum Wire Size	Wire Type
30, 60, 100A DG	(7) #14	(7) #4	CU/AL
200A DG	(3) #14	(3) #2	CU/AL
400, 600A DG	(4) #6	(4) 250 kcmil	CU/AL
30, 60, 100A DH	(7) #14	(7) #4	CU/AL
200A DH Type 1 and 3R	(3) #14	(3) #2	CU/AL
200A DH Type 4X and 12	(2) #14	(2) #2	CU/AL
400A, 600A, 800A, 1200A DH	(4) #6	(4) 250 kcmil	CU/AL
30, 60, 100A DT	(7) #14	(7) #4	CU/AL
200A DT	(5) #14	(5) #2	CU/AL
400A DT	(6) #6	(6) 250 kcmil	CU/AL
600A, 800A, 1200A DT	(6) #6	(6) 250 kcmil	CU/AL

Ground Lug Kit Capacities

Ground Lug Kit	Minimum Wire Size	Maximum Wire Size	Wire Type
DG030GB	#14	#4	CU/AL
DS100GK	(7) #14	(7) #4	CU/AL
DS200GK	(2) #14	(2) #2	CU/AL
DS468GK	(2) #6	(2) 250 kcmil	CU/AL

Note

- ^① Additional Grounding is available as a Factory Modification, through the Switching Device Flex Center. Add Suffix G to the end of switch catalog number.

Neutral Lug Kit Capacities

Neutral Kit	Minimum Wire Size	Maximum Wire Size	Wire Type
DG030NB	(2) #14	(2) #4	CU/AL
DG100NB	(3) #14	(3) #1/0	CU/AL
DG200NK	(2) #6 (2) #14	(2) 300 kcmil (2) #2	CU/AL and
DH030NK	(4) #14	(4) #2	CU/AL
DH100NK	(2) #14 (2) #14	(2) #2 (2) #1/0	CU/AL and
DH200NK	(2) #14 (2) #6	(2) #2 (2) 300 kcmil	CU/AL and
DS400NK	(2) #1/0 (4) #2 (3) #6	(2) 750 kcmil (4) 600 kcmil (3) 250 kcmil	CU/AL or and
DS600NK	(2) #1/0 (2) #2 (3) #6	(2) 750 kcmil (2) 600 kcmil (3) 250 kcmil	CU/AL and
DS800NK	(8) #1/0 (3) #6	(8) 750 kcmil (3) 250 kcmil	CU/AL and
DT100NK	#14 (3) #14	#2 (3) #1/0	CU/AL and
DT200NK	#14 (3) #6	#2 (3) 250 kcmil	CU/AL and
DT400NK	(7) #6	(7) 250 kcmil	CU/AL
DT600NK	#6 (6) 250 kcmil	250 kcmil (6) 500 kcmil	CU/AL and
DS800NK	(3) #6 (8) #1/0	(3) 250 kcmil (8) 750 kcmil	CU/AL and
DT800NK	(2) #6 (9) 250 kcmil	(2) 250 kcmil (9) 500 kcmil	CU/AL and
DT1200NK	(3) #6 (12) #1/0	(3) 250 kcmil (12) 750 kcmil	CU/AL and

General-Duty**Short-Circuit Ratings Using Class “R,” “J” or “T” Fusing Where Applicable** ^①

Ampere Rating	Short-Circuit Ratings (Amperes)	
	Type 1	Type 3R
30	100k at 240V	100k at 240V
60	100k at 240V	100k at 240V
100	100k at 240V	100k at 240V
200	100k at 240V	100k at 240V
400	100k at 250V	100k at 250V
600	100k at 250V	100k at 250V

Shunt Trip Safety Switch**Short-Circuit Ratings Using Class “R,” “J,” “L” or “T” Fusing Where Applicable** ^②

Ampere Rating	Short-Circuit Ratings (Amperes)	
	480V	600V
30	200 kAIC	200 kAIC
60	200 kAIC	200 kAIC
100	200 kAIC	200 kAIC
200	200 kAIC	100 kAIC
400	200 kAIC	100 kAIC
600	200 kAIC	100 kAIC
800	200 kAIC	200 kAIC

Heavy-Duty**Short-Circuit Ratings Using Class “R,” “J,” “L” or “T” Fusing Where Applicable** ^①

Ampere Rating	Short-Circuit Ratings (Amperes)			
	Type 1	Type 3R	Type 12	Type 4 and 4X
30	200k at 600V	200k at 600V	200k at 600V	200k at 600V
60	200k at 600V	200k at 600V	200k at 600V	200k at 600V
100	200k at 480V 100k at 600V	200k at 480V 100k at 600V	200k at 600V	200k at 600V
200	200k at 600V	200k at 600V	200k at 600V	200k at 600V
400	200k at 480V 100k at 600V	200k at 480V 100k at 600V	200k at 480V 100k at 600V	200k at 480V 100k at 600V
600	200k at 480V 100k at 600V	200k at 480V 100k at 600V	200k at 480V 100k at 600V	200k at 480V 100k at 600V
800 ^③	200k at 480V 100k at 600V	200k at 480V 100k at 600V	200k at 480V 100k at 600V	200k at 480V 100k at 600V
1200 ^③	200k at 600V	200k at 600V	200k at 600V	200k at 600V

Double Throw**Short-Circuit Ratings Using Class “R,” “J,” “L” or “T” Fusing where Applicable** ^{③④⑤⑥⑦}

Ampere Rating	Short-Circuit Ratings (Amperes) (600V)			
	Type 1	Type 3R	Type 12	Type 4 and 4X
30	100k	100k	100k	100k
60	100k	100k	100k	100k
100	100k	100k	100k	100k
200	100k	100k	100k	100k
400	100k	100k	100k	100k
600	100k	100k	100k	100k
800	100k	100k	—	—
1200	100k	100k	—	—

Notes

- ① Class “H” fuse clips supplied as standard for 30–600A. Rated at 10,000A rms symmetrical when using Class “H” fuses.
- ② Non-fusible values are based on combination rating with upstream device (see TD00801005E).
- ③ Class “L” fuse connectors supplied as standard for 800A and 1200A.
- ④ Class “H” fuse clips supplied as standard for 30–600A, except Class “T” for 400A at 600V and 600A at 240V. Rated at 10,000A rms symmetrical when using Class “H” fuses.
- ⑤ Safety switch short-circuit ratings are applicable to AC only.
- ⑥ Safety switch I^2t and I_p values are identical to UL maximum acceptable I^2t and I_p values for the corresponding class fuse.
- ⑦ Table above is not applicable to the compact design shown on **Page V2-T1-47**. The compact design is suitable for use on a circuit capable of delivering not more than 10,000 rms symmetrical amperes.

Short-Circuit Ratings of Non-Fusible Switches

The UL listed short-circuit ratings for Eaton non-fusible switches are based on the switches being properly protected by overcurrent protective devices. For applications that require a UL listed short-circuit rating of 10,000 rms symmetrical amperes or less, an Eaton non-fusible switch must be properly protected by any overcurrent protective device rated no greater than the ampere rating of the switch. For applications that require a UL listed short-circuit rating of greater than 10,000 rms symmetrical amperes, an Eaton non-fusible switch

must be properly protected by the appropriate class and size fusing noted. Otherwise, this non-fusible switch must be replaced with an Eaton fusible switch that uses the appropriate fusing required. Molded case circuit breaker protection of non-fusible Eaton switches for applications that require a short-circuit rating of greater than 10,000 rms symmetrical amperes has been evaluated and is summarized below. Refer to the reference tables for typical Eaton fusible switch UL listed short-circuit ratings.

UL Recognized Safety Switch/Circuit Breaker Series-Connected Ratings

Safety Switch Ampere Rating	Maximum System Voltage AC	Circuit Breaker Maximum Short-Circuit Rating (rms Symmetrical)	Circuit Breaker Frame(s)
30 and 60	600	25,000	FDC, HFD, HFDE, EGH
		18,000	FD, EGE
		14,000	FDB
100	600	25,000	FDC, HFD, HFDE, EGH
		18,000	FD, EGE
		14,000	FDB
	480	35,000	EGH, EGS
200	600	25,000	FDC, HFD, HFDE, HJD, JGH
		18,000	FD, JD, JGE
		14,000	FDB
	480	65,000	HFD, HFDE, HJD, JGH

1

Product Enhancement

Eaton non-fusible safety switches, per table below, within the noted ampere ratings, now carry series combination short-circuit ratings as shown when combined with the identified MCCB or fuse type. With this listed rating, the safety switch shown in the one-line diagram, can be correctly applied **when the motor feeder Eaton HMCP circuit breaker is replaced with an**

Eaton molded case circuit breaker properly sized for the motor hp rating. This is a significant enhancement to the product's performance rating. To achieve these ratings, the switches have been tested in combination with all of the overcurrent devices shown. Furthermore, the applicable combination ratings are marked on the inside of the switch door, ensuring inspector approval.

One-Line Diagram

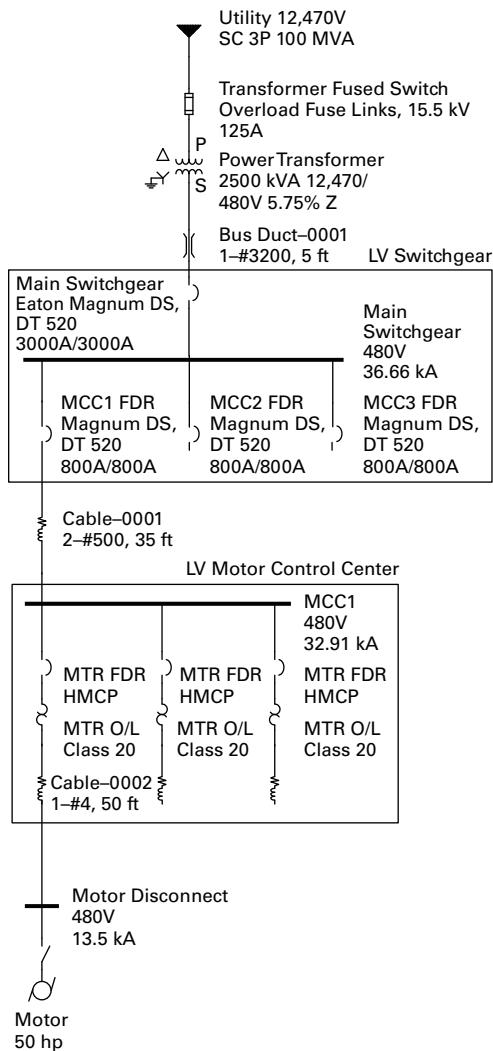

Information and Application

The circuit breaker or fuse rating is not to exceed the ampere rating of the non-fusible switch. When used on systems with greater than 10 kA short-circuit rating available, the UL Listed short-

circuit rating of the non-fusible switch is based upon the switch being used in combination with fuses or molded case circuit breakers identified in the table below.

Non-Fusible Safety Switches

Eaton Non-Fusible Safety Switch Ampere Rating ^①	Maximum System Voltage AC	Maximum Short-Circuit Rating	Upstream Device ^②	
			Fuse Class	Breaker Frame
30 and 60	600	10,000	H, K	Any circuit breaker
		14,000		FDB
		18,000		FD, EGE
		25,000		FDC, HFD, HFDE, EGH
		200,000	R, T, J, L	
100	480	10,000	H, K	Any circuit breaker
		35,000		EGH, EGS
	600	10,000	H, K	Any circuit breaker
		14,000		FDB
		18,000		FD, EGE
200	480	10,000	H, K	Any circuit breaker
		65,000		HFD, HFDE, HJD, JGH
	600	10,000	H, K	Any circuit breaker
		14,000		FDB
		18,000		FD, JD, JGE
200,000 ^③	600	25,000		FDC, HFD, HFDE, HJD, JGH
		200,000	R, T, J, L	

Notes

- ① For use on NEMA 1, 3R, 12/3R and 4X switches.
- ② Fuse or circuit breaker rating is not to exceed switch rating.
- ③ NEMA 12, 4/4X only. NEMA 1, 3R are 100 kAIC at 600 Vac.

Dimensions

Typical Fuse Dimensions in Inches

Note: For typical fuse dimensions in millimeters, see **Page V2-T1-24**.

Class T

T-Tron™ Fuses

JJN (300V)

JJS (600V)

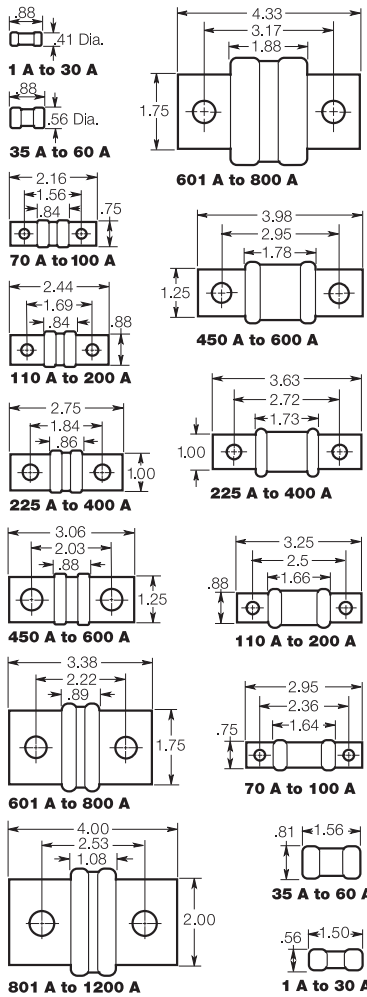

Class J

Low-Peak® and Limitron® Fuses

LPJ & JKS (600V)

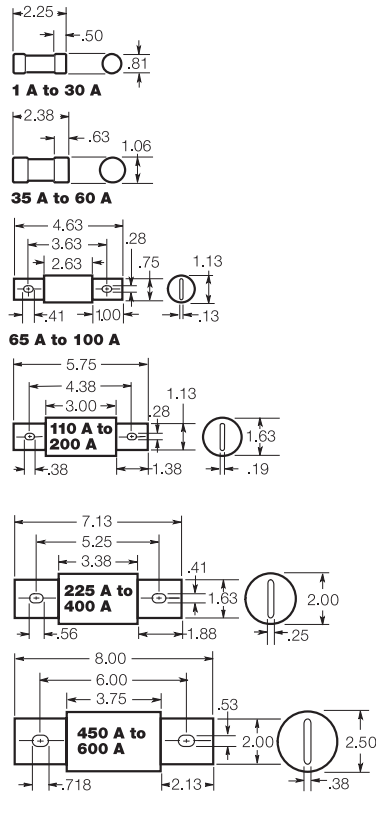

Class RK5 and RK1, Class H

(Dimensions Apply)

Fusetron®, Low-Peak and Limitron Fuses (250 and 600V)

FRN-R and FRS-R; LPN-RK and LPS-RK; KTN-R and KTS-R
Basic dimensions are same as Class H (formerly NEC) ONE-TIME (NON and NOS) and SUPERLAG Renewable RES and REN fuses.

Note: These fuses can be used to replace existing Class H, RK1 and RK5 fuses relating to dimensional compatibility.

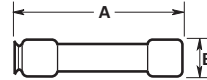

Ampere	250V		600V	
	A	B	A	B
1/10-30	2.00	0.56	5.00	0.81
35-60	3.00	0.81	5.50	1.06

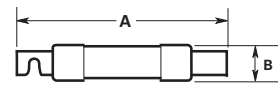

Fusetron and Limitron

Ampere	250V		600V	
	A	B	A	B
70-100	5.88	1.06	7.88	1.34
110-200	7.13	1.56	9.63	1.84
225-400	8.63	2.06	11.63	2.59
450-600	10.38	2.59	13.38	3.13

Low-Peak

Ampere	250V		600V	
	A	B	A	B
70-100	5.88	1.16	7.88	1.16
110-200	7.13	1.66	9.63	1.66
225-400	8.63	2.38	11.63	2.38
450-600	10.38	2.88	13.38	2.88

Class L Low-Peak and Limitron Fuses

KRP-C, KTU & KLU (601-4000A) (600V)

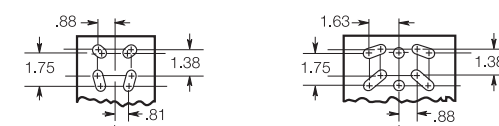

Note: KRP-CL (150-600A) fuses have same dimensions as 601-800A case size. KTU (200-600A) have same dimensions, except tube 3-inch lgth. x 2-inch dia.; terminal 1.63-inch width x 1.25-inch thick.

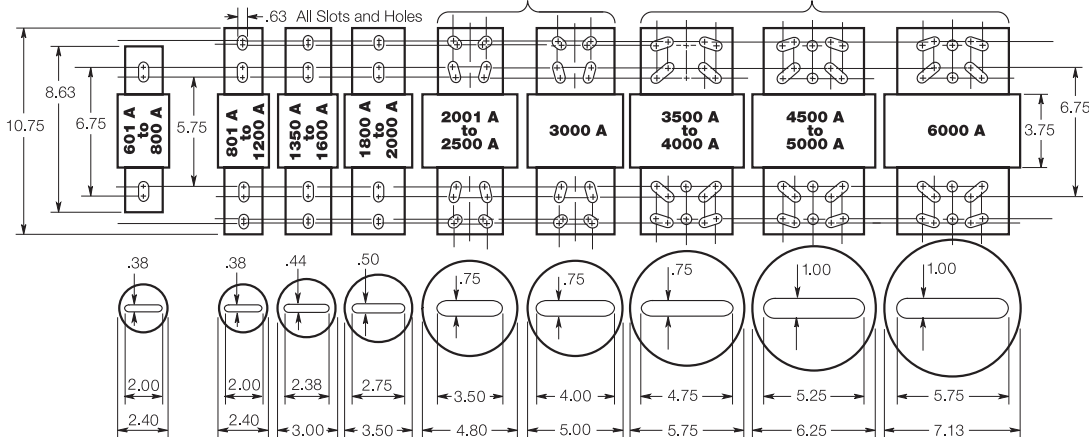

Typical Fuse Dimensions in Millimeters

Class T

T-Tron Fuses
JJN (300V)

1 A to 30 A
10.3 Dia.

35 A to 60 A
14.3 Dia.

70 A to 100 A

110 A to 200 A

225 A to 400 A

450 A to 600 A

601 A to 800 A

801 A to 1200 A

JJS (600V)

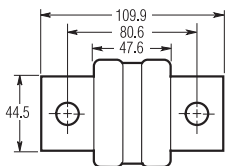

601 A to 800 A

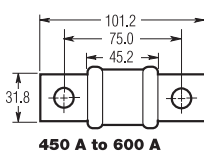

450 A to 600 A

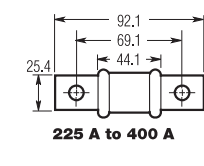

225 A to 400 A

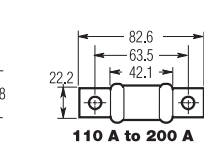

110 A to 200 A

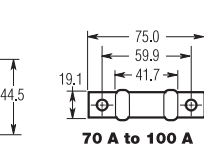

70 A to 100 A

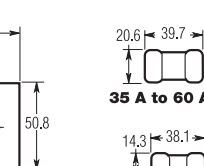

35 A to 60 A

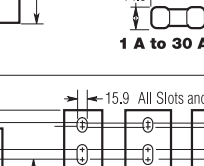

1 A to 30 A

Class J

Low-Peak and Limitron Fuses
LPJ and JKS (600V)

1 A to 30 A

35 A to 60 A

65 A to 100 A

110 A to 200 A

225 A to 400 A

450 A to 600 A

601 A to 800 A

801 A to 1200 A

1 A to 30 A

35 A to 60 A

65 A to 100 A

110 A to 200 A

225 A to 400 A

450 A to 600 A

601 A to 800 A

801 A to 1200 A

1 A to 30 A

35 A to 60 A

65 A to 100 A

110 A to 200 A

225 A to 400 A

450 A to 600 A

601 A to 800 A

801 A to 1200 A

Fusetron, Low-Peak and Limitron Fuses (250 and 600V)
FRN-R and FRS-R; LPN-RK and LPS-RK; KTN-R and KTS-R

Basic dimensions are same as Class H (formerly NEC) ONE-TIME (NON and NOS) and SUPERLAG Renewable RES and REN fuses.

Note: These fuses can be used to replace existing Class H, RK1 and RK5 fuses relating to dimensional compatibility.

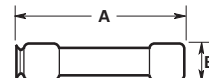

Ampere	250V		600V	
	A	B	A	B
1/10-30	50.8	14.3	127.0	20.6
35-60	76.2	20.6	139.7	27.0



Fusetron and Limitron

Ampere	250V		600V	
	A	B	A	B
70-100	149.2	26.9	200.0	34.0
110-200	181.0	39.6	244.5	46.7
225-400	219.1	52.3	295.3	65.8
450-600	263.5	65.8	339.7	79.5

Low-Peak

Ampere	250V		600V	
	A	B	A	B
70-100	149.2	29.5	200.0	29.5
110-200	181.0	42.2	244.5	42.2
225-400	219.1	60.5	295.3	60.5
450-600	263.5	73.2	339.7	73.2

Class L Low-Peak and Limitron Fuses

KRP-C, KTU and KLU (601-4000A) (600V)

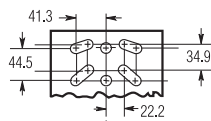
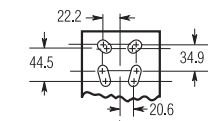

Note: KRP-CL (150-600A) fuses have same dimensions as 601-800A case size. KTU (200-600A) have same dimensions, except tube 76.2 mm lgth. x 50.8 mm dia.; terminal 41.3 mm width x 31.8 mm thick.

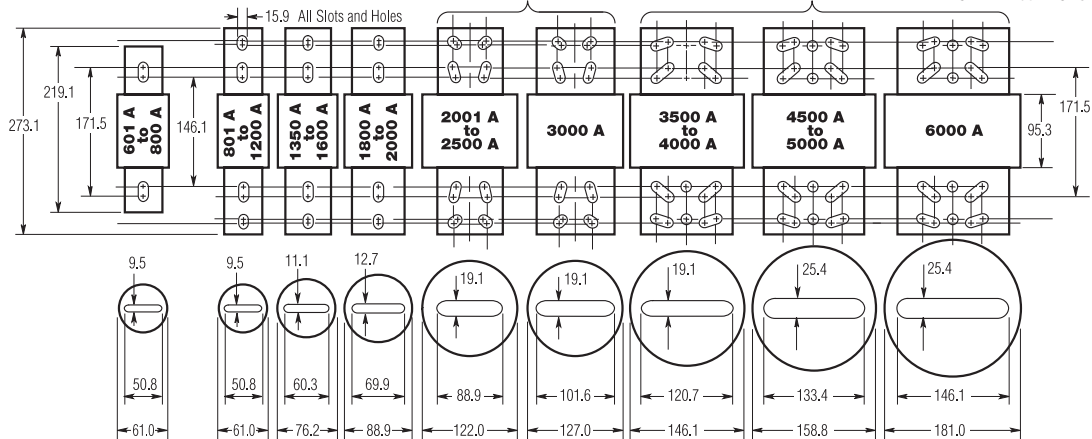

Cartridge Fuse General-Duty Safety Switch



Contents

<i>Description</i>	<i>Page</i>
Product Overview	V2-T1-2
General Duty	V2-T1-25
Standards and Certifications	V2-T1-26
Product Selection	V2-T1-27
Dimensions	V2-T1-29
Heavy-Duty	V2-T1-30
Heavy-Duty Double Door Safety Switch	V2-T1-39
Six-Pole Switches	V2-T1-43
Double-Throw Switches	V2-T1-46
EnviroLine Stainless Steel Switch	V2-T1-53
Window Switches	V2-T1-57
Receptacle Switches	V2-T1-60
Non-Metallic KRYDON Switch	V2-T1-62
Shunt Trip Safety Switch	V2-T1-65
NEMA 7/9—Hazardous Location Disconnect Switch	V2-T1-68
Quick-Connect Switches	V2-T1-70
Solar Disconnect Switch	V2-T1-75
Mill-Duty Rated, Heavy-Duty Safety Switch	V2-T1-77
Heavy-Duty Fusible Safety Switches Accepting CUBEFuses	V2-T1-79
Elevator Control Switch	V2-T1-82
Auxiliary Power Heavy-Duty Safety Switch	V2-T1-85
Left-Handed Safety Switch	V2-T1-89
Heavy-Duty Surge Switch	V2-T1-90
OEM Line Isolation (OLI) Switch	V2-T1-92
Pringle Bolted Pressure Switch	V2-T1-95
Type DS, Fusible and Non-Fusible	V2-T1-98
Type Visi-Flex DE-ION	V2-T1-101
Flange Mounted—Variable Depth	V2-T1-105
Flange Mounted—Fixed Depth	V2-T1-109

General Duty

Product Description

- 30–600A
- Suitable for service entrance applications unless otherwise noted
- Fusible and non-fusible switches are 100% load break and 100% load make rated
- The continuous load current of fusible switches is not to exceed 80% of the rating of fuses employed in other than motor circuits. Non-fusible switches are 100% fully rated
- 200–600A features K-Series design
- Horsepower rated

- Fusible and non-fusible switches. Single-pole S/N through four-wire; 120/240, and 240 Vac
- With Class R fuses, switches may be used on systems capable of delivering 100,000A rms symmetrical

Note: Plug fuse switches are not service entrance rated.

- Bolt-on hub provision. Provided for general-duty switches in a NEMA 3R enclosure. See **Page V2-T1-14** for selection

Application Description

For residential and commercial applications. Suitable for light-duty motor circuits and service entrance.

Features, Benefits and Functions

General-Duty (Cartridge Fuse)

- Ample wire bending space provides for easier installation
- Visible double-break quick-make, quick-break rotary blade mechanism
- Side opening door on all enclosures
- Mechanically interlocked cover to prevent easy access when the switch is in the ON position
- With Class R fuses, switches may be used on systems capable of delivering 100,000A rms symmetrical
- Clearly visible and accessible neutral where applicable
- Visible ON/OFF indication
- Tangential knockouts on 30–60A designs
- Ample wiring space
- Double padlocking capability on 30–100A
- Triple padlocking capability on 200–600A
- Additional door locking capability
- Bilingual English/Spanish door label on 30–100A
- Tri-lingual nameplates

All general-duty switches above 100A and all heavy-duty switches incorporate these K-Series switch design features.

- Two points of contact provide a positive open and close, easier operation, and also help prevent contact burning for longer contact life

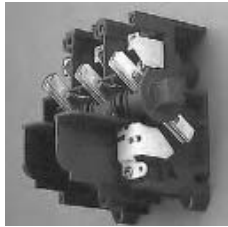

Visible Double-Break Rotary Blade Mechanism

- Protects against accidental contact with energized parts. Probe holes enable the user to test if the line side is energized without removing the shield. Not provided on general-duty switches, but available as a field kit or factory installed



Clear Line Shield



Clearly Visible Handle

- The position (ON or OFF) can be clearly seen from a distance and the length provides for easy operation



Triple Padlocking Capability

- Personnel safety feature because the large hasp can accommodate up to three 3/8-inch (9.5 mm) shank locks



Additional Locking Capability

- Cabinet door can be further padlocked at the top and bottom as applicable

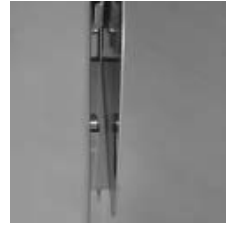

Interlocking Mechanism

- Door cannot be opened when the handle is in the ON position. Front and side operable defeater mechanism provides for user access when necessary on single-throw switches



Tangential Knockouts

- An ample number are provided on the top, bottom and sides of both NEMA Types 1 and 3R enclosures through 200A



Bolt-On Hub Kits

- For switches in a NEMA Type 3R, 30–200A. Use a Myers type hub for all others

Standards and Certifications

- UL listed File No. E5239
- Meets UL 98 for enclosed switches and NEMA Std. KS-1



Seismic Qualifications

- General-duty switches exceed the requirements of Uniform Building Code (UBC) and California Code Title 24 OSP-0011-10, OSP-0012-10



Product Selection

120/240 Vac General-Duty, Fusible, Single-Throw

DP221NGB



System	Ampere Rating	Fuse Type Provision	Maximum Horsepower Ratings ^①			DC 250V	NEMA 1 Enclosure Indoor Catalog Number	NEMA 3R Enclosure Rainproof Catalog Number
			Single-Phase AC 120V	240V	Three-Phase AC 240V			
Plug Type—Two-Wire (One Blade, One Fuse, S/N)—120 Vac^②								
	30	Plug (Type S, T or W)	1/2–2	—	—	—	DP111NGB ^②	—
Plug Type—Three-Wire (Two Blades, Two Fuses, S/N)—120/240 Vac								
	30	Plug (Type S, T or W)	1/2–2	1-1/2–3	—	—	DP221NGB ^②	Use cartridge-type fuse catalog number DG221NRB
Cartridge Type—Two-Pole Two-Wire (Two Blades, Two Fuses)—240 Vac								
	30	—	—	1-1/2–3	3–7-1/2	—	③	③
	60	—	—	3–10	7-1/2–15	—	③	③
	100	—	—	7-1/2–15	15–30	—	③	③
	200	H	—	15	25–60	—	DG224FGK ^{④⑤}	DG224FRK ^{④⑤}
	400	H	—	—	50–125	—	DG225FGK ^{④⑤}	DG225FRK ^{④⑤}
	600	H	—	—	75–200	—	DG226FGK ^{④⑤}	DG226FRK ^{④⑤}
Cartridge Type—Three-Wire (Two Blades, Two Fuses, S/N)—120/240 Vac								
	30	H	—	1-1/2–3	3–7-1/2 ^⑥	—	DG221NGB	DG221NRB
	60	H	—	3–10	7-1/2–15 ^⑥	—	DG222NGB	DG222NRB
	100	H	—	7-1/2–15	15–30 ^⑥	—	DG223NGB	DG223NRB
	200	H	—	15	25–60 ^⑥	—	DG224NGK	DG224NRK
	400	H	—	—	50–125 ^⑥	50	DG225NGK	DG225NRK
	600	H	—	—	75–200 ^⑥	—	DG226NGK	DG226NRK

Notes

- ① Maximum hp ratings apply only when dual element time delay fuses are used.
- ② These switches do not have an interlock that prevents door from being opened when switch is in the ON position.
- ③ Use three-wire catalog numbers below.
- ④ Solid neutral bars are not included. Order separately from table on **Page V2-T1-13**.
- ⑤ **WARNING!** Switch is not approved for service entrance unless a neutral kit is installed.
- ⑥ Grounded B phase rating, UL listed.

All general-duty safety switches are individually packaged.

Accessories are limited in scope on general-duty safety switches. See **Page V2-T1-13** for availability. In addition, clear line shields are available as an accessory on 200–600A general-duty switches. Catalog Numbers: 200A = 70-7759-11, 400A = 70-8063-8, 600A = 70-8064-8.

DG321NRB



120/240 Vac General-Duty, Fusible, Single-Throw, continued

System	Ampere Rating	Fuse Type Provision	Maximum Horsepower Ratings ^①			DC 250V	NEMA 1 Enclosure Indoor Catalog Number	NEMA 3R Enclosure Rainproof Catalog Number
			Single-Phase AC 120V	240V	Three-Phase AC 240V			
Cartridge Type—Three-Pole, Three-Wire (Three Blades, Three Fuses)—240 Vac								
	30	—	—	—	—	—	②	②
	60	—	—	—	—	—	②	②
	100	—	—	—	—	—	②	②
	200	H	—	15	25–60	—	DG324FGK ^{③④}	②
	400	H	—	—	50–125	—	DG325FGK ^{③④}	DG325FRK ^{③④}
	600	H	—	—	75–200	—	DG326FGK ^{③④}	DG326FRK ^{③④}
Cartridge Type—Four-Wire (Three Blades, Three Fuses, S/N)—120/240 Vac								
	30	H	—	1-1/2–3	3–7-1/2	—	DG321NGB	DG321NRB
	60	H	—	3–10	7-1/2–15	—	DG322NGB	DG322NRB
	100	H	—	7-1/2–15	15–30	—	DG323NGB	DG323NRB
	200	H	—	15	25–60	—	DG324NGK	DG324NRK
	400	H	—	—	50–125	—	DG325NGK	DG325NRK
	600	H	—	—	75–200	—	DG326NGK	DG326NRK

DG322URB



120/240 Vac General-Duty, Non-Fusible, Single-Throw

System	Ampere Rating	Maximum Horsepower Ratings			DC 250V	NEMA 1 Enclosure Indoor Catalog Number	NEMA 3R Enclosure Rainproof Catalog Number
		Single-Phase AC 120V	240V	Three-Phase AC 240V			
Two-Pole, Two-Wire (Two Blades)—240 Vac							
	30	2	3	—	—	DG221UGB ^④	DG221URB ^④
	60	3	10	—	—	DG222UGB ^④	DG222URB ^④
	100	—	15	—	—	DG223UGB ^④	DG223URB ^④
	200	—	15	—	—	④⑤	DG224URK ^④
Three-Pole, Three-Wire (Three Blades)—240 Vac							
	30	2	3	7-1/2	—	DG321UGB ^④	DG321URB ^④
	60	3	10	15	—	DG322UGB ^④	DG322URB ^④
	100	—	15	30	—	DG323UGB ^④	DG323URB ^④
	200	—	15	60	—	DG324UGK ^④	DG324URK ^④
	400	—	—	125	—	DG325UGK ^④	DG325URK ^④
	600	—	—	200	—	DG326UGK ^④	DG326URK ^④

Notes

- ① Maximum hp ratings apply only when dual element time delay fuses are used.
- ② Use four-wire catalog numbers below.
- ③ Solid neutral bars are not included. Order separately from table on **Page V2-T1-13**.
- ④ **WARNING!** Switch is not approved for service entrance unless a neutral kit is installed.
- ⑤ Use three-wire catalog numbers below.

All general-duty safety switches are individually packaged.

Accessories are limited in scope on general-duty safety switches. See **Page V2-T1-13** for availability. In addition, clear line shields are available as an accessory on 200–600A general-duty switches. Catalog Numbers: 200A = 70-7759-11, 400A = 70-8063-8, 600A = 70-8064-8.

Dimensions

Approximate Dimensions in Inches (mm)

Plug Fuse, 120, 120/240V, Single-, Two-Pole Solid Neutral, Single-Throw

Ampere Rating	NEMA 1 Height	Width	Depth
30	6.88 (174.8)	4.94 (125.5)	3.44 (87.4)

General-Duty, Non-Fusible, 240V, Three-Pole, Single-Throw ①

Ampere Rating	Width (W)	Height (H)	Depth (D)	Depth (D2)	Weight Lbs (kg)
NEMA 1					
30	6.38 (162.1)	10.69 (271.5)	6.88 (174.8)	3.75 (95.2)	6 (2.724)
60	8.69 (220.7)	14.19 (360.4)	7.38 (187.5)	4.21 (106.9)	9 (4.086)
100	9.13 (231.9)	18.81 (477.8)	7.38 (187.5)	4.23 (107.4)	12 (5.448)
200	16.00 (406.4)	24.75 (628.7)	11.25 (285.8)	6.14 (156.0)	48 (21.792)
400	23.00 (584.2)	44.75 (1136.7)	12.63 (320.8)	7.27 (184.7)	100 (45.4)
600	24.00 (609.6)	52.25 (1327.2)	14.25 (362.0)	8.95 (227.3)	130 (59.02)
NEMA 3R					
30	6.38 (162.1)	10.81 (274.6)	6.88 (174.8)	3.75 (95.2)	6 (2.724)
60	8.69 (220.7)	14.38 (365.3)	7.38 (187.5)	4.21 (106.9)	9 (4.086)
100	9.13 (231.9)	19.25 (489.0)	7.38 (187.5)	4.23 (107.4)	12 (5.448)
200	16.00 (406.4)	25.50 (647.7)	11.25 (285.8)	6.14 (156.0)	55 (24.97)
400	23.00 (584.2)	45.19 (1147.8)	12.63 (320.8)	7.27 (184.7)	105 (47.67)
600	24.00 (609.6)	52.70 (1338.6)	14.25 (362.0)	8.95 (227.3)	135 (61.29)

NEMA 1, 3R 30–100A General-Duty Non-Fusible and Fusible Single-Throw ②

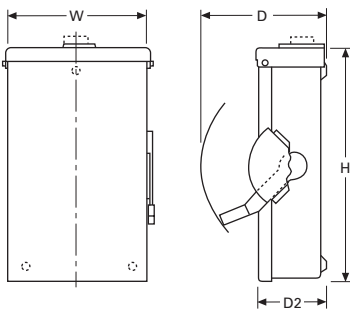

General-Duty, Fusible, 240V, Three-Pole Solid Neutral, Single-Throw ①

Ampere Rating	Width (W)	Height (H)	Depth (D)	Depth (D2)	Weight Lbs (kg)
NEMA 1					
30	6.38 (162.1)	10.69 (271.5)	6.88 (174.8)	3.75 (95.2)	6 (2.724)
60	8.69 (220.7)	14.19 (360.4)	7.38 (187.5)	4.21 (106.9)	10 (4.54)
100	9.13 (231.9)	18.81 (477.8)	7.38 (187.5)	4.23 (107.4)	14 (6.356)
200	16.00 (406.4)	24.75 (628.7)	11.25 (285.8)	6.14 (156.0)	48 (21.792)
400	23.00 (584.2)	44.75 (1136.7)	12.63 (320.8)	7.27 (184.7)	110 (49.94)
600	24.00 (609.6)	52.25 (1327.2)	14.25 (362.0)	8.95 (227.3)	145 (65.83)
NEMA 3R					
30	6.38 (162.1)	10.81 (274.6)	6.88 (174.8)	3.75 (95.2)	6 (2.724)
60	8.69 (220.7)	14.38 (365.3)	7.38 (187.5)	4.21 (106.9)	10 (4.54)
100	9.13 (231.9)	19.25 (489.0)	7.38 (187.5)	4.23 (107.4)	14 (6.356)
200	16.00 (406.4)	25.50 (647.7)	11.25 (285.8)	6.14 (156.0)	55 (24.97)
400	23.00 (584.2)	45.19 (1147.8)	12.63 (320.8)	7.27 (184.7)	115 (52.21)
600	24.00 (609.6)	52.70 (1338.6)	14.25 (362.0)	8.95 (227.3)	150 (68.1)

NEMA 1, 3R 200–600A General-Duty Non-Fusible and Fusible Single-Throw

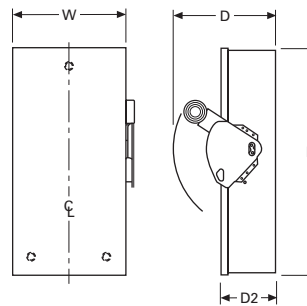

Notes

- ① Dimensions are for estimating purposes only.
- ② Figure is not applicable to plug fuse.

Heavy-Duty Safety Switch



Heavy-Duty

Product Description

- 30–1200A
- 600 Vac, 600 Vdc maximum
- Horsepower rated
- Fusible and non-fusible switches are 100% load break and 100% load make rated
- The continuous load current of fusible switches is not to exceed 80% of the rating of fuses employed in other than motor circuits. Non-fusible switches are 100% fully rated
- Suitable for service entrance applications unless otherwise noted
- For factory modifications, refer to **Page V2-T1-15**

Application Description

For heavy commercial and industrial applications where reliable performance and service continuity are critical.

For the toughest heavy commercial and industrial applications, refer to **Page V2-T1-77** for catalog information on our mill-duty safety switch.

316 Grade stainless steel is often a desirable choice for wastewater treatment plants and petrochemical facilities.

Contents

<i>Description</i>	<i>Page</i>
Product Overview	V2-T1-2
General Duty	V2-T1-25
Heavy-Duty	
Standards and Certifications	V2-T1-30
Product Selection	V2-T1-32
Dimensions	V2-T1-38
Heavy-Duty Double Door Safety Switch	V2-T1-39
Six-Pole Switches	V2-T1-43
Double-Throw Switches	V2-T1-46
EnviroLine Stainless Steel Switch	V2-T1-53
Window Switches	V2-T1-57
Receptacle Switches	V2-T1-60
Non-Metallic KRYDON Switch	V2-T1-62
Shunt Trip Safety Switch	V2-T1-65
NEMA 7/9—Hazardous Location Disconnect Switch	V2-T1-68
Quick-Connect Switches	V2-T1-70
Solar Disconnect Switch	V2-T1-75
Mill-Duty Rated, Heavy-Duty Safety Switch	V2-T1-77
Heavy-Duty Fusible Safety Switches Accepting CUBEFuses	V2-T1-79
Elevator Control Switch	V2-T1-82
Auxiliary Power Heavy-Duty Safety Switch	V2-T1-85
Left-Handed Safety Switch	V2-T1-89
Heavy-Duty Surge Switch	V2-T1-90
OEM Line Isolation (OLI) Switch	V2-T1-92
Pringle Bolted Pressure Switch	V2-T1-95
Type DS, Fusible and Non-Fusible	V2-T1-98
Type Visi-Flex DE-ION	V2-T1-101
Flange Mounted—Variable Depth	V2-T1-105
Flange Mounted—Fixed Depth	V2-T1-109

Features, Benefits and Functions

- Deionizing arc chutes; arc chutes confine and suppress the arcs produced by opening contacts under load
- Mechanically interlocked cover to prevent easy access when the switch is in the ON position
- Clearly visible palm fitting red handle
- Premium 316-Grade stainless steel enclosures offer better corrosion resistance in the presence of most chemicals, salts and acids, and is more resistant to marine atmospheres
- Visible double-break quick-make, quick-break blades
- Visible ON/OFF indication
- 30–1200A NEMA 12 designs convertible to NEMA 3R by opening factory-installed drain hole
- Tri-lingual nameplates

Standards and Certifications

- UL listed File No. E5239
- Meets UL 98 for enclosed switches and NEMA Std. KS-1



Seismic Qualifications

- Heavy-duty switches exceed the requirements of Uniform Building Code (UBC) and California Code Title 24 OSP-0011-10, OSP-0012-10



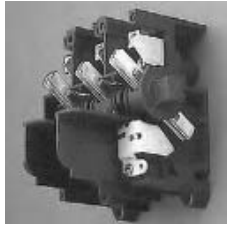

Visible Double-Break Rotary Blade Mechanism

- Two points of contact provide a positive open and close, easier operation, and also help prevent contact burning for longer contact life



Clear Line Shield

- Protects against accidental contact with energized parts. Probe holes enable the user to test if the line side is energized without removing the shield. Not typically provided on general-duty switches, but available as a field kit or factory installed



Built-In Fuse Pullers (NEMA 12 and 4X 30–200A Only)

- Provide easy removal of fuses



Clearly Visible Handle

- The position (ON or OFF) can be clearly seen from a distance and the length provides for easy operation



Triple Padlocking Capability

- Personnel safety feature because the large hasp can accommodate up to three 3/8-inch (9.5 mm) shank locks



Additional Locking Capability

- Cabinet door can be further padlocked at the top and bottom as applicable



Interlocking Mechanism

- Door cannot be opened when the handle is in the ON position. Front and side operable defeater mechanism provides for user access when necessary on single-throw switches



Tangential Knockouts

- An ample number are provided on the top, bottom and sides of both NEMA Types 1 and 3R enclosures through 200A



Bolt-On Hub Kits

- For switches in a NEMA Type 3R, 30–200A. Use a Myers type hub for all others

Product Selection

DH221NRK



240 Vac Heavy-Duty, Single-Throw, Fusible—NEMA 1, 3R, 12/3R

System	Maximum Horsepower Ratings						DC 250V	NEMA 1 Enclosure Indoor Catalog Number	NEMA 3R Enclosure Rainproof Catalog Number	NEMA 12/3R Enclosure Industrial, Dust-Tight Catalog Number
	Ampere Rating	Fuse Type Provision	AC Standard Fuse		Time Delay					
			Single-Phase	Three-Phase	Single-Phase	Three-Phase				
Two-Pole—240 Vac, 250 Vdc (Suitable for Service Entrance Use with a Neutral Kit Installed)										
	30	H	1-1/2	—	—	—	5	DH221FGK ^①	^③	^③
	60	—	—	—	—	—	—	^③	^③	^③
	100	—	—	—	—	—	—	^③	^③	^③
	200	—	—	—	—	—	—	^③	^③	^③
	400	H	—	50 ^{①②}	—	125 ^{①②}	50	DH225FGK	DH225FRK	DH225FDK ^⑤
	600	H	—	75 ^{①②}	—	200 ^{①②}	—	DH226FGK	DH226FRK	DH226FDK ^⑤
	800	L	—	100 ^{①②}	—	—	—	DH227FGK	—	DH227FDK ^⑤
Three-Wire (Two Blades, Two Fuses, S/N)—240 Vac, 250 Vdc										
	30	H	1-1/2	3 ^④	3	7-1/2 ^④	5	DH221NGK ^①	DH221NRK ^①	DH221NDK ^{①⑤}
	60	H	3	7-1/2 ^④	10	15 ^④	10	DH222NGK	DH222NRK	DH222NDK ^⑤
	100	H	7-1/2	15 ^④	15	30 ^④	20	DH223NGK	DH223NRK	DH223NDK ^⑤
	200	H	15	25 ^④	15	60 ^④	40	DH224NGK	DH224NRK	DH224NDK ^⑤
	400	H	—	50 ^④	—	125 ^④	50	DH225NGK	DH225NRK	DH225NDK ^⑤
	600	H	—	75 ^④	—	200 ^④	—	DH226NGK	DH226NRK	DH226NDK ^⑤
	800	L	—	100 ^④	—	—	—	DH227NGK	DH227NRK	DH227NDK ^⑤
Three-Pole—240 Vac, 250 Vdc (Suitable for Service Entrance Use with a Neutral Kit Installed)										
	30	H	1-1/2	3	3	7-1/2	5	DH321FGK ^①	DH321FRK ^①	DH321FDK ^{①⑤}
	60	H	3	7-1/2	10	15	10	DH322FGK	DH322FRK	DH322FDK ^⑤
	100	H	7-1/2	15	15	30	20	DH323FGK	DH323FRK	DH323FDK ^⑤
	200	H	15	25	15	60	40	DH324FGK	DH324FRK	DH324FDK ^⑤
	400	H	—	50	—	125	50	DH325FGK	DH325FRK	DH325FDK ^⑤
	600	H	—	75	—	200	—	DH326FGK	DH326FRK	DH326FDK ^⑤
	800	L	—	100	—	—	—	DH327FGK	DH327FRK	DH327FDK ^⑤
	1200	L	—	—	—	—	—	DH328FGK	DH328FRK	DH328FDK ^⑤
Four-Wire (Three Blades, Three Fuses, S/N)—240 Vac, 250 Vdc										
	30	H	1-1/2	3	3	7-1/2	5	DH321NGK ^①	DH321NRK ^①	DH321NDK ^{①⑤}
	60	H	3	7-1/2	10	15	10	DH322NGK	DH322NRK	DH322NDK ^⑤
	100	H	7-1/2	15	15	30	20	DH323NGK	DH323NRK	DH323NDK ^⑤
	200	H	15	25	15	60	40	DH324NGK	DH324NRK	DH324NDK ^⑤
	400	H	—	50	—	125	50	DH325NGK	DH325NRK	DH325NDK ^⑤
	600	H	—	75	—	200	—	DH326NGK	DH326NRK	DH326NDK ^⑤
	800	L	—	100	—	—	—	DH327NGK	DH327NRK	DH327NDK ^{⑤⑥}
	1200	L	—	—	—	—	—	DH328NGK	DH328NRK	DH328NDK ^⑤
Four-Pole—240 Vac, 250 Vdc ^⑦										
	30	H	3	3	10	7-1/2	5	DH421FGK ^①	^⑤	DH421FDK ^{①⑤}
	60	H	7-1/2	7-1/2	20	15	10	DH422FGK	^⑤	DH422FDK ^⑤
	100	H	15	15	30	30	20	DH423FGK	^⑤	DH423FDK ^⑤
	200	H	30	25	50	60	40	DH424FGK	^⑤	DH424FDK ^⑤
	400	H	50	50	—	125	50	DH425FGK	^{⑤⑥}	^{⑤⑥}
	600	H	—	75	—	200	—	DH426FGK	^{⑤⑥}	^{⑤⑥}



Notes

- ① 30A heavy-duty switches with Type J fuse provisions are available from the factory only.
- ② Horsepower ratings apply only when neutral is field installed and switch is used on a grounded B phase system.
- ③ Use three-pole catalog numbers below.
- ④ Grounded B phase ratings, UL listed.
- ⑤ Use NEMA 12. NEMA 12 enclosures (30–1200A) can be field modified to meet NEMA 3R rainproof requirements when a factory provided drain hole is opened.
- ⑥ Contact the Safety Switch Flex Center (1-888-329-9272 or FlexSwitches@eaton.com) for availability of this product.
- ⑦ NOT suitable for service entrance use per NEC 215.10 and 230.95.

DH322FWK

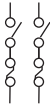
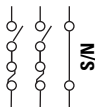

240 Vac Heavy-Duty, Single-Throw, Fusible—NEMA 4, 4X, 4X 316 Stainless-Steel

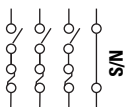
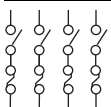
System	Maximum Horsepower Ratings						DC 250V	NEMA 4 Enclosure Watertight, Painted Steel Catalog Number	NEMA 4X Enclosure Corrosion- Resistant, Stainless Steel Catalog Number	NEMA 4X Enclosure Corrosion- Resistant, 316-Grade Stainless Steel Catalog Number
	Ampere Rating	Fuse Type Provision	AC		Time Delay					
			Single- Phase	Three- Phase	Single- Phase	Three- Phase				
Two-Pole—240 Vac, 250 Vdc (Suitable for Service Entrance Use with a Neutral Kit Installed)										
	30	H	1-1/2	—	—	—	5	—	③	③
	60	—	—	—	—	—	—	—	③ or ④	③ or ④
	100	—	—	—	—	—	—	—	④	④
	200	—	—	—	—	—	—	—	④	④
	400	H	—	50 ①	—	125 ①	50	DH225FPK	④	④
	600	H	—	75 ①	—	200 ①	—	DH226FPK	④	④
	800	L	—	100 ①	—	—	—	—	④	④
Three-Wire (Two Blades, Two Fuses, S/N)—240 Vac, 250 Vdc										
	30	H	1-1/2	3 ②	3	7-1/2 ②	5	—	DH221NWK ⑤	DH221NWK316 ⑤
	60	H	3	7-1/2 ②	10	15 ②	10	—	DH222NWK	DH222NWK316
	100	H	7-1/2	15 ②	15	30 ②	20	—	DH223NWK	DH223NWK316
	200	H	15	25 ②	15	60 ②	40	—	DH224NWK	DH224NWK316
	400	H	—	50 ②	—	125 ②	50	DH225NPK	DH225NWK	DH225NWK316
	600	H	—	75 ②	—	200 ②	—	DH226NPK	DH226NWK	DH226NWK316
	800	L	—	100 ②	—	—	—	DH227NPK	DH227NWK	DH227NWK316
Three-Pole—240 Vac, 250 Vdc (Suitable for Service Entrance Use with a Neutral Kit Installed)										
	30	H	1-1/2	3	3	7-1/2	5	—	DH321FWK ⑤	DH321FWK316 ⑤
	60	H	3	7-1/2	10	15	10	—	DH322FWK	DH322FWK316
	100	H	7-1/2	15	15	30	20	—	DH323FWK	DH323FWK316
	200	H	15	25	15	60	40	—	DH324FWK	DH324FWK316
	400	H	—	50	—	125	50	DH325FPK	DH325FWK	DH325FWK316
	600	H	—	75	—	200	—	DH326FPK	DH326FWK	DH326FWK316
	800	L	—	100	—	—	—	DH327FPK	DH327FWK	DH327FWK316
	1200	L	—	—	—	—	—	—	DH328FWK	DH328FWK316
Four-Wire (Three Blades, Three Fuses, S/N)—240 Vac, 250 Vdc										
	30	H	1-1/2	3	3	7-1/2	5	—	DH321NWK ⑤	DH321NWK316 ⑤
	60	H	3	7-1/2	10	15	10	—	DH322NWK	DH322NWK316
	100	H	7-1/2	15	15	30	20	—	DH323NWK	DH323NWK316
	200	H	15	25	15	60	40	—	DH324NWK	DH324NWK316
	400	H	—	50	—	125	50	DH325NPK	DH325NWK	DH325NWK316
	600	H	—	75	—	200	—	DH326NPK	DH326NWK	DH326NWK316
	800	L	—	100	—	—	—	—	④	④
	1200	L	—	—	—	—	—	—	DH328NWK	DH328NWK316
Four-Pole—240 Vac, 250 Vdc ⑥										
	30	H	3	3	10	7-1/2	5	—	④	④
	60	H	7-1/2	7-1/2	20	15	10	—	④	④
	100	H	15	15	30	30	20	—	④	④
	200	H	30	25	50	60	40	—	④	④
	400	H	50	50	—	125	50	—	④	④
	600	H	—	75	—	200	—	—	④	④

Notes

- ① Horsepower ratings apply only when neutral is field installed and switch is used on a grounded B phase system.
- ② Grounded B phase ratings, UL listed.
- ③ Use three-pole catalog numbers below.
- ④ Contact the Safety Switch Flex Center (1-888-329-9272 or FlexSwitches@eaton.com) for availability of this product.
- ⑤ 30A heavy-duty switches with Type J fuse provisions are available from the factory only.
- ⑥ NOT suitable for service entrance use per NEC 215.10 and 230.95.

DH362NRK



600 Vac Heavy-Duty, Fusible, Single-Throw, 277/480–600V—NEMA 1, 3R, 12/3R

System	Ampere Rating	Fuse Class Provision	Maximum Horsepower Ratings with Time Delay Fuses						NEMA 1 Enclosure Indoor Catalog Number	NEMA 3R Enclosure Rainproof Catalog Number	NEMA 12/3R ^① Enclosure Industrial, Dust-Tight Catalog Number
			Single-Phase AC		Three-Phase AC		DC				
			480V	600V	480V	600V	250V	600V			
Two-Pole—480 Vac—600 Vac or Vdc^② (Suitable for Service Entrance Use with a Neutral Kit Installed)											
	30	H	7-1/2	10	—	—	—	15	DH261FGK ^③	DH261FRK ^③	DH261FDK ^③
	60	H	20	25	—	—	—	25	DH262FGK	DH262FRK	DH262FDK
	100	H	30	40	—	—	20	25	DH263FGK	DH263FRK	DH263FDK
	200	H	50	50	—	—	40	50	DH264FGK	DH264FRK	DH264FDK
	400	H	—	—	—	—	50	—	DH265FGK	DH265FRK	DH265FDK
	600	H	—	—	—	—	50	—	DH266FGK	DH266FRK	DH266FDK
	800	L	—	—	—	—	—	—	DH267FGK	DH267FRK	DH267FDK
	1200	L	—	—	—	—	—	—	④	—	④
Three-Pole—480 Vac—600 Vac, 250 Vdc (Suitable for Service Entrance Use with a Neutral Kit Installed)											
	30	H	7-1/2	10	15	20	—	—	DH361FGK ^③	DH361FRK ^③	DH361FDK ^③
	60	H	20	25	30	50	—	—	DH362FGK	DH362FRK	DH362FDK
	100	H	30	40	60	75	—	—	DH363FGK	DH363FRK	DH363FDK
	200	H	50	50	125	150	—	—	DH364FGK	DH364FRK	DH364FDK
	400	H	—	—	250	350	—	—	DH365FGK	DH365FRK	DH365FDK
	600	H	—	—	400	500	—	—	DH366FGK	DH366FRK	DH366FDK
	800	L	—	—	500	500	—	—	DH367FGK	DH367FRK	DH367FDK
	1200	L	—	—	500	500	—	—	DH368FGK ^⑥	DH368FRK ^⑥	DH368FDK ^⑥
Four-Wire (Three Blades, Three Fuses, S/N) 480 Vac—600 Vac, 250 Vdc											
	30	H	7-1/2	10	15	20	—	—	DH361NGK ^③	DH361NRK ^③	DH361NDK ^③
	60	H	20	25	30	50	—	—	DH362NGK	DH362NRK	DH362NDK
	100	H	30	40	60	75	—	—	DH363NGK	DH363NRK	DH363NDK
	200	H	50	50	125	150	—	—	DH364NGK	DH364NRK	DH364NDK
	400	H	—	—	250	350	—	—	DH365NGK	DH365NRK	DH365NDK
	600	H	—	—	400	500	—	—	DH366NGK	DH366NRK	DH366NDK
	800	L	—	—	500	500	—	—	DH367NGK	DH367NRK	④
	1200	L	—	—	500	500	—	—	DH368NGK ^⑥	DH368NRK ^⑥	DH368NDK ^⑥
Four-Pole—480 Vac—600 Vac, 250 Vdc^⑥											
	30	H	20 ^⑤	25 ^⑤	15	20	—	—	DH461FGK ^③	①	④
	60	H	40 ^⑤	50 ^⑤	30	50	—	—	DH462FGK	①	④
	100	H	50 ^⑤	50 ^⑤	60	75	—	—	DH463FGK	①	DH463FDK
	200	H	—	—	125	150	40	—	DH464FGK	①	DH464FDK
	400	H	—	—	250	350	50	—	DH465FGK	①④	④
	600	H	—	—	400	500	—	—	DH466FGK	①④	④
	800	L	—	—	—	—	—	—	③	①④	④

Notes

- ① NEMA 12 enclosures (30–1200A) can be field modified to meet NEMA 3R rainproof requirements when a factory provided drain hole is opened.
- ② DC rating for 800A switches is 250V.
- ③ 30A heavy-duty switches with Type J fuse provisions are available from the factory only.
- ④ Contact the Safety Switch Flex Center (1-888-329-9272 or FlexSwitches@eaton.com) for availability of this product.
- ⑤ Ratings are for two-phase AC.
- ⑥ NOT suitable for service entrance use per NEC 215.10 and 230.95.

600 Vac Heavy-Duty, Fusible, Single-Throw, 277/480–600V—NEMA 4, 4X, 4X 316 Stainless-Steel

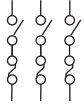
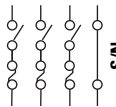
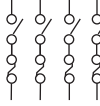
System	Ampere Rating	Fuse Class Provision	Maximum Horsepower Ratings with Time Delay Fuses						NEMA 4 Enclosure Watertight, Painted Steel Catalog Number	NEMA 4X Enclosure Corrosion-Resistant, Stainless Steel Catalog Number	NEMA 4X Enclosure Corrosion-Resistant, 316-Grade Stainless Steel Catalog Number
			Single-Phase AC		Three-Phase AC		DC				
			480V	600V	480V	600V	250V	600V			
Two-Pole—480 Vac—600 Vac or Vdc ^① (Suitable for Service Entrance Use with a Neutral Kit Installed)											
	30	H	7-1/2	10	—	—	—	15	—	DH261FWK ^②	DH261FWK316 ^②
	60	H	20	25	—	—	—	25	—	③ or ④	③ or ④
	100	H	30	40	—	—	20	—	—	③ or ④	③ or ④
	200	H	50	50	—	—	—	50	—	DH264FWK	DH264FWK316
	400	H	—	—	—	—	50	—	④	③ or ④	③ or ④
	600	H	—	—	—	—	—	—	④	③ or ④	③ or ④
	800	L	—	—	—	—	—	—	④	③ or ④	③ or ④
	1200	L	—	—	—	—	—	—	—	④	③
Three-Pole—480 Vac—600 Vac, 250 Vdc (Suitable for Service Entrance Use with a Neutral Kit Installed)											
	30	H	7-1/2	10	15	20	—	—	—	DH361FWK ^②	DH361FWK316 ^②
	60	H	20	25	30	50	—	—	—	DH362FWK	DH362FWK316
	100	H	30	40	60	75	—	—	—	DH363FWK	DH363FWK316
	200	H	50	50	125	150	—	—	—	DH364FWK	DH364FWK316
	400	H	—	—	250	350	—	—	DH365FPK	DH365FWK	DH365FWK316
	600	H	—	—	400	500	—	—	DH366FPK	DH366FWK	DH366FWK316
	800	L	—	—	500	500	—	—	DH367FPK	DH367FWK	DH367FWK316
	1200	L	—	—	500	500	—	—	—	DH368FWK ^⑤	DH368FWK316 ^⑤
Four-Wire (Three Blades, Three Fuses, S/N) 480 Vac—600 Vac, 250 Vdc											
	30	H	7-1/2	10	15	20	—	—	—	DH361NWK ^②	DH361NWK316 ^②
	60	H	20	25	30	50	—	—	—	DH362NWK	DH362NWK316
	100	H	30	40	60	75	—	—	—	DH363NWK	DH363NWK316
	200	H	50	50	125	150	—	—	—	DH364NWK	DH364NWK316
	400	H	—	—	250	350	—	—	DH365NPK	DH365NWK	DH365NWK316
	600	H	—	—	400	500	—	—	DH366NPK	DH366NWK	DH366NWK316
	800	L	—	—	500	500	—	—	—	DH367NWK ^③	③
	1200	L	—	—	500	500	—	—	—	DH368NWK ^⑤	DH368NWK316 ^⑤
Four-Pole—480 Vac—600 Vac, 250 Vdc											
	30	H	20 ^⑥	25 ^⑥	15	20	—	—	—	③	③
	60	H	40 ^⑥	50 ^⑥	30	50	—	—	—	③	③
	100	H	50 ^⑥	50 ^⑥	60	75	—	—	—	③	③
	200	H	—	—	125	150	40	—	—	③	③
	400	H	—	—	250	350	50	—	—	③	③
	600	H	—	—	400	500	—	—	—	③	③
	800	L	—	—	—	—	—	—	—	③	③



Notes

- ① DC rating for 800A switches is 250V.
- ② 30A heavy-duty switches with Type J fuse provisions are available from the factory only.
- ③ Contact the Safety Switch Flex Center (1-888-329-9272 or FlexSwitches@eaton.com) for availability of this product.
- ④ Use three-pole catalog numbers below for 600 Vac, 250 Vdc maximum applications.
- ⑤ NOT suitable for service entrance use per NEC 215.10 and 230.95.
- ⑥ Ratings are for two-phase AC.

DH362UGK



600 Vac Heavy-Duty, Non-Fusible, Single-Throw, 277/480–600V – NEMA 1, 3R, 12/3R

System	Ampere Rating	Maximum Horsepower Ratings									NEMA 1 Enclosure Indoor Catalog Number	NEMA 3R Enclosure Rainproof Catalog Number	NEMA 12/3R Enclosure Industrial, Dust-Tight Catalog Number
		Single-Phase AC			Three-Phase AC			DC					
		240V	480V	600V	240V	480V	600V	250V	600V				
Two-Pole—480 Vac—600 Vac or Vdc ^① (Suitable for Service Entrance Use with a Neutral Kit Installed)													
	30	3	7-1/2	10	—	—	—	—	15	DH261UGK	DH261URK	DH261UDK ^⑤	
	60	10	20	25	—	—	—	—	25	DH262UGK	DH262URK	DH262UDK ^⑤	
	100	20	30	40	—	—	—	20	25	DH263UGK	DH263URK	DH263UDK ^⑤	
	200	15	50	50	—	—	—	—	50	DH264UGK	DH264URK	DH264UDK ^⑤	
	400	—	—	—	—	—	—	50	50	DH265UGK	DH265URK	DH265UDK ^⑤	
	600	—	—	—	—	—	—	—	50	DH266UGK	DH266URK	DH266UDK ^⑤	
	800	—	—	—	—	—	—	—	—	DH267UGK	DH267URK	DH267UDK ^⑤	
	1200	—	—	—	—	—	—	—	—	^②	—	^②	
Three-Pole—480 Vac—600 Vac, 250 Vdc (Suitable for Service Entrance Use with a Neutral Kit Installed)													
	30	3	7-1/2	10	10	20	30	5	—	DH361UGK	DH361URK	DH361UDK ^⑤	
	60	10	20	25	20	50	60	10	—	DH362UGK	DH362URK	DH362UDK ^⑤	
	100	20	40	50	40	75	100	20	—	DH363UGK	DH363URK	DH363UDK ^⑤	
	200	15	50	50	60	125	150	40	—	DH364UGK	DH364URK	DH364UDK ^⑤	
	400	—	—	—	125	250	350	50	—	DH365UGK	DH365URK	DH365UDK ^⑤	
	600	—	—	—	200	400	500	—	—	DH366UGK	DH366URK	DH366UDK ^⑤	
	800	—	—	—	—	500	500	—	—	DH367UGK	DH367URK	DH367UDK ^⑤	
	1200	—	—	—	—	500	500	—	—	DH368UGK ^③	DH368URK ^③	DH368UDK ^③	
Four-Pole—480 Vac—600 Vac, 250 Vdc ^③													
	30	10 ^④	20 ^④	25 ^④	10	20	30	5	—	DH461UGK	^⑤	DH461UDK ^⑤	
	60	20 ^④	40 ^④	50 ^④	20	50	60	10	—	DH462UGK	^⑤	DH462UDK ^⑤	
	100	40 ^④	50 ^④	50 ^④	40	75	100	20	—	DH463UGK	^⑤	DH463UDK ^⑤	
	200	50 ^④	50 ^④	50 ^④	60	125	150	40	—	DH464UGK	^⑤	DH464UDK ^⑤	
	400	50 ^④	—	—	125	250	350	50	—	DH465UGK	^{②⑤}	^{②⑤}	
	600	—	—	—	200	400	500	—	—	DH466UGK	^{②⑤}	^{②⑤}	
	800	—	—	—	—	—	—	—	—	^②	^{②⑤}	^{②⑤}	



Notes

- ^① DC rating for 800A switches is 250V.
- ^② Contact the Safety Switch Flex Center (1-888-329-9272 or FlexSwitches@eaton.com) for availability of this product.
- ^③ NOT suitable for service entrance use per NEC 215.10 and 230.95.
- ^④ Ratings are for two-phase AC.
- ^⑤ NEMA 12 enclosures (30–1200A) can be field modified to meet NEMA 3R rainproof requirements when a factory provided drain hole is opened.

DH361UWK

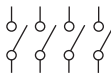

600 Vac Heavy-Duty, Non-Fusible, Single-Throw, 277/480–600V—NEMA 4, 4X, 4X 316 Stainless Steel

System	Ampere Rating	Maximum Horsepower Ratings									NEMA 4 Enclosure Watertight, Painted Steel Catalog Number	NEMA 4X Enclosure Corrosion-Resistant, Stainless Steel Catalog Number	NEMA 4X Enclosure Corrosion-Resistant, 316-Grade Stainless Steel Catalog Number
		Single-Phase AC			Three-Phase AC			DC					
		240V	480V	600V	240V	480V	600V	250V	600V				
Two-Pole—480 Vac—600 Vac or Vdc^① (Suitable for Service Entrance Use with a Neutral Kit Installed)													
	30	3	7-1/2	10	—	—	—	—	15	—	② or ③	② or ③	
	60	10	20	25	—	—	—	—	25	—	② or ③	② or ③	
	100	20	30	40	—	—	—	20	25	—	② or ③	② or ③	
	200	15	50	50	—	—	—	—	50	—	② or ③	② or ③	
	400	—	—	—	—	—	—	50	—	③	② or ③	② or ③	
	600	—	—	—	—	—	—	—	—	③	② or ③	② or ③	
	800	—	—	—	—	—	—	—	—	③	② or ③	② or ③	
	1200	—	—	—	—	—	—	—	—	—	②	②	
Three-Pole—480 Vac—600 Vac, 250 Vdc (Suitable for Service Entrance Use with a Neutral Kit Installed)													
	30	3	7-1/2	10	10	20	30	5	—	—	DH361UWK	DH361UWK316	
	60	10	20	25	20	50	60	10	—	—	DH362UWK	DH362UWK316	
	100	20	40	50	40	75	100	20	—	—	DH363UWK	DH363UWK316	
	200	15	50	50	60	125	150	40	—	—	DH364UWK	DH364UWK316	
	400	—	—	—	125	250	350	50	—	DH365UPK	DH365UWK	DH365UWK316	
	600	—	—	—	200	400	500	—	—	DH366UPK	DH366UWK	DH366UWK316	
	800	—	—	—	—	500	500	—	—	DH367UPK	DH367UWK	DH367UWK316	
	1200	—	—	—	—	500	500	—	—	—	DH368UWK ^④	DH368UWK316 ^④	
Four-Pole—480 Vac—600 Vac, 250 Vdc^④													
	30	10 ^⑤	20 ^⑤	25 ^⑤	10	20	30	5	—	—	DH461UWK	DH461UWK316	
	60	20 ^⑤	40 ^⑤	50 ^⑤	20	50	60	10	—	—	②	②	
	100	40 ^⑤	50 ^⑤	50 ^⑤	40	75	100	20	—	—	②	②	
	200	50 ^⑤	50 ^⑤	50 ^⑤	60	125	150	40	—	—	②	②	
	400	50 ^⑤	—	—	125	250	350	50	—	—	②	②	
	600	—	—	—	200	400	500	—	—	—	②	②	
	800	—	—	—	—	—	—	—	—	—	②	②	

Notes

- ① DC rating for 800A switches is 250V.
- ② Contact the Safety Switch Flex Center (1-888-329-9272 or FlexSwitches@eaton.com) for availability of this product.
- ③ Use three-pole catalog numbers below for 600 Vac, 250 Vdc maximum applications. For 600 Vdc, see note ②.
- ④ NOT suitable for service entrance use per NEC 215.10 and 230.95.
- ⑤ Ratings are for two-phase AC.

Dimensions

Approximate Dimensions in Inches (mm)

Note: Dimensions are for estimating purposes only.

Heavy-Duty, Non-Fusible, 600V, Three-Pole, Single-Throw

Ampere Rating	Width (W)	Height (H)	Depth (D)	Depth (D2)	Weight Lbs (kg)
NEMA 1, 3R					
30	8.13 (206.5)	15.88 (403.4)	10.00 (254.0)	5.25 (133.3)	16 (7.264)
60	8.13 (206.5)	15.88 (403.4)	10.00 (254.0)	5.25 (133.3)	16 (7.264)
100	11.13 (282.7)	21.69 (550.9)	10.00 (254.0)	5.25 (133.3)	22 (9.988)
200	16.00 (406.4)	27.66 (702.5)	11.25 (285.5)	6.14 (156.0)	46 (20.884)
400	24.12 (612.6)	44.31 (1125.5)	12.39 (314.7)	7.27 (184.7)	110 (49.94)
600	25.12 (638.0)	51.82 (1316.2)	14.07 (357.4)	8.95 (227.3)	135 (61.29)
800	26.37 (669.8)	55.82 (1417.8)	14.07 (357.4)	8.95 (227.3)	158 (71.732)
1200	43.12 (1095.2)	70.97 (1802.6)	17.12 (434.8)	12.43 (315.7)	430 (195.22)
NEMA 12, 4X Stainless Steel, 4, 4X 316 Stainless Steel					
30	8.76 (222.5)	14.14 (359.2)	10.22 (259.6)	5.50 (139.7)	17 (7.718)
60	8.76 (222.5)	14.14 (359.2)	10.22 (259.6)	5.50 (139.7)	17 (7.718)
100	11.79 (299.5)	24.95 (633.7)	10.22 (259.6)	5.50 (139.7)	28 (12.712)
200	16.95 (430.5)	35.38 (898.7)	11.63 (295.4)	6.44 (163.6)	55 (24.97)
400	24.12 (612.6)	57.47 (1459.7)	12.43 (320.8)	7.19 (182.6)	125 (56.75)
600	25.01 (635.3)	62.97 (1599.4)	12.79 (324.9)	8.95 (227.3)	167 (75.818)
800	26.35 (669.3)	71.72 (1821.7)	12.79 (324.9)	8.95 (227.3)	175 (79.45)
1200	43.11 (1095.0)	73.77 (1873.8)	17.15 (435.6)	12.45 (316.2)	475 (215.65)

Heavy-Duty, Fusible, 240V and 600V, Three-Pole Solid Neutral, Single-Throw

Ampere Rating	Width (W)	Height (H)	Depth (D)	Depth (D2)	Weight Lbs (kg)
NEMA 1, 3R					
30	8.13 (206.5)	15.88 (403.4)	10.00 (254.0)	5.25 (133.3)	20 (9.08)
60	8.13 (206.5)	15.88 (403.4)	10.00 (254.0)	5.25 (133.3)	20 (9.08)
100	11.13 (282.7)	21.69 (550.9)	10.00 (254.0)	5.25 (133.3)	27 (12.258)
200	16.00 (406.4)	27.66 (702.5)	11.25 (285.5)	6.14 (156.0)	46 (20.884)
400	24.12 (612.6)	44.31 (1125.5)	12.39 (314.7)	7.27 (184.7)	110 (49.94)
600	25.12 (638.0)	51.82 (1316.2)	14.07 (357.4)	8.95 (227.3)	135 (61.29)
800	26.37 (669.8)	55.82 (1417.8)	14.07 (357.4)	8.95 (227.3)	158 (71.732)
1200	43.12 (1095.2)	70.97 (1802.6)	17.12 (434.8)	12.43 (315.7)	430 (195.22)
NEMA 12, 4X Stainless Steel, 4, 4X 316 Stainless Steel					
30	8.76 (222.5)	19.08 (359.2)	10.22 (259.6)	5.50 (139.7)	22 (9.988)
60	8.76 (222.5)	19.08 (359.2)	10.22 (259.6)	5.50 (139.7)	22 (9.988)
100	11.79 (299.5)	24.95 (633.7)	10.22 (259.6)	5.50 (139.7)	28 (12.712)
200	16.95 (430.5)	35.38 (898.7)	11.63 (295.4)	6.44 (163.6)	55 (24.97)
400	24.12 (612.6)	57.47 (1459.7)	12.43 (320.8)	7.19 (182.6)	125 (56.75)
600	25.01 (635.3)	62.97 (1599.4)	12.79 (324.9)	8.95 (227.3)	167 (75.818)
800	26.35 (669.3)	71.72 (1821.7)	12.79 (324.9)	8.95 (227.3)	175 (79.45)
1200	43.11 (1095.0)	73.77 (1873.8)	17.15 (435.6)	12.45 (316.2)	475 (215.65)

NEMA 1, 3R Heavy-Duty 30–1200A

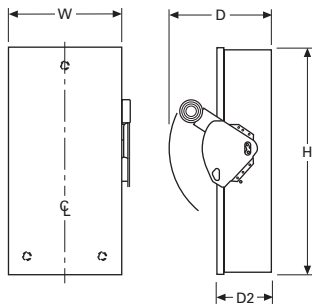

NEMA 4, 4X and 12 Heavy-Duty 30–1200A

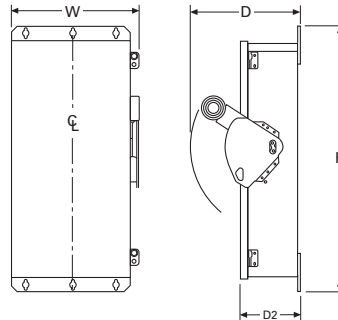

Note: A factory-installed ground lug is supplied in all heavy-duty safety switches.

Heavy-Duty Double Door Safety Switch



Heavy-Duty Double Door Safety Switch

Product Description

Eaton's double-door safety switch is the industry's first compartmentalized fusible safety switch. The revolutionary two-door design includes an internal barrier that separates the upper switching compartment from the lower fuse compartment. This allows operators to access the fuse compartment with no exposure to line-side power, providing enhanced safety during fuse replacement.

Features

- 30–1200A
- NEMA 12/3R and NEMA 4X stainless enclosures
- External viewing window over switching blade standard
- Enhanced visible blades included
- Interlocking mechanism keeps door closed when the switch is ON
- Optional voltage monitors

Contents

Description

	<i>Page</i>
Product Overview	V2-T1-2
General Duty	V2-T1-25
Heavy-Duty	V2-T1-30
Heavy-Duty Double Door Safety Switch	
Catalog Number Selection	V2-T1-40
Product Selection	V2-T1-41
Modifications	V2-T1-42
Technical Data and Specifications	V2-T1-42
Dimensions	V2-T1-42
Six-Pole Switches	
Double-Throw Switches	V2-T1-46
EnviroLine Stainless Steel Switch	V2-T1-53
Window Switches	V2-T1-57
Receptacle Switches	V2-T1-60
Non-Metallic KRYDON Switch	V2-T1-62
Shunt Trip Safety Switch	V2-T1-65
NEMA 7/9—Hazardous Location Disconnect Switch	V2-T1-68
Quick-Connect Switches	V2-T1-70
Solar Disconnect Switch	V2-T1-75
Mill-Duty Rated, Heavy-Duty Safety Switch	V2-T1-77
Heavy-Duty Fusible Safety Switches Accepting CUBEFuses	V2-T1-79
Elevator Control Switch	V2-T1-82
Auxiliary Power Heavy-Duty Safety Switch	V2-T1-85
Left-Handed Safety Switch	V2-T1-89
Heavy-Duty Surge Switch	V2-T1-90
OEM Line Isolation (OLI) Switch	V2-T1-92
Pringle Bolted Pressure Switch	V2-T1-95
Type DS, Fusible and Non-Fusible	V2-T1-98
Type Visi-Flex DE-ION	V2-T1-101
Flange Mounted—Variable Depth	V2-T1-105
Flange Mounted—Fixed Depth	V2-T1-109

Standards and Certifications

- UL 98 Standard, file no. E5239



1.1

Switching Devices

Safety Switches

1

Catalog Number Selection

Heavy-Duty Double Door Safety Switch

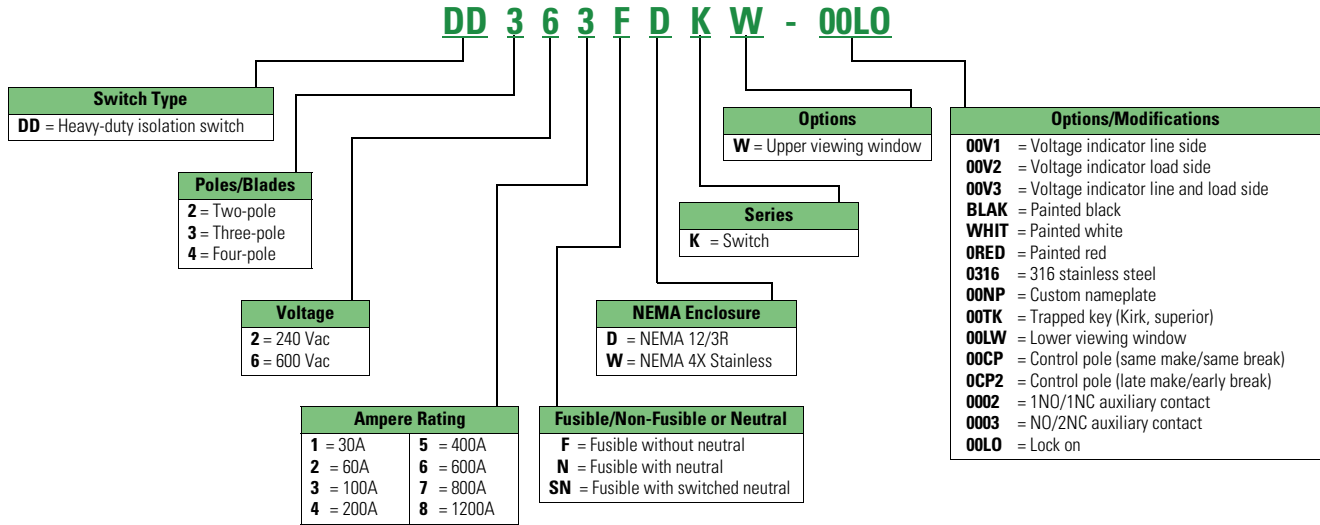

Product Selection

DD321FDKW



240 Vac Heavy-Duty Double Door, Fusible—NEMA 12/3R, 4X

System	Ampere Rating	Fuse Type Provision	Maximum hp Ratings with Time Delay Fuses						NEMA 12/3R Enclosure Dust-tight Catalog Number	NEMA 4X Enclosure Watertight Catalog Number
			Single-Phase AC		Three-Phase AC		DC			
			480V	600V	480V	600V	250V	600V		
Three-Pole, 240 Vac, 250 Vdc (Suitable for Service Entrance Use with a Neutral Kit Installed)										
	30	H	7.5	10	15	20	—	—	DD321FDKW	DD321FWKW
	60	H	20	25	30	50	—	—	DD322FDKW	DD322FWKW
	100	H	30	40	60	75	—	—	DD323FDKW	DD323FWKW
	200	H	50	50	125	150	—	—	DD324FDKW	DD324FWKW
	400	H	—	—	250	350	—	—	DD325FDKW	DD325FWKW
	600	H	—	—	400	500	—	—	DD326FDKW	DD326FWKW
	800	L	—	—	500	500	—	—	DD327FDKW	DD327FWKW
	1200	L	—	—	500	500	—	—	DD328FDKW	DD328NWKW
Four-Wire (Three Blades, Three Fuses, S/N) 240 Vac, 250 Vdc										
	30	H	7.5	10	15	20	—	—	DD321NDKW	DD321NWKW
	60	H	20	25	30	50	—	—	DD322NDKW	DD322NWKW
	100	H	30	40	60	75	—	—	DD323NDKW	DD323NWKW
	200	H	50	50	125	150	—	—	DD324NDKW	DD324NWKW
	400	H	—	—	250	350	—	—	DD325NDKW	DD325NWKW
	600	H	—	—	400	500	—	—	DD326NDKW	DD326NWKW
	800	L	—	—	500	500	—	—	DD327NDKW	DD327NWKW
	1200	L	—	—	500	500	—	—	DD328NDKW	DD328NWKW

DD361FDKW



600 Vac Heavy-Duty Double Door, Fusible—NEMA 12/3R, 4X

System	Ampere Rating	Fuse Type Provision	Maximum hp Ratings with Time Delay Fuses						NEMA 12/3R Enclosure Dust-tight Catalog Number	NEMA 4X Enclosure Watertight Catalog Number
			Single-Phase AC		Three-Phase AC		DC			
			480V	600V	480V	600V	250V	600V		
Three-Pole, 480 Vac–600 Vac or Vdc (Suitable for Service Entrance Use with a Neutral Kit Installed)										
	30	H	7.5	10	15	20	—	—	DD361FDKW	DD361FWKW
	60	H	20	25	30	50	—	—	DD362FDKW	DD362FWKW
	100	H	30	40	60	75	—	—	DD363FDKW	DD363FWKW
	200	H	50	50	125	150	—	—	DD364FDKW	DD364FWKW
	400	H	—	—	250	350	—	—	DD365FDKW	DD365FWKW
	600	H	—	—	400	500	—	—	DD366FDKW	DD366FWKW
	800	L	—	—	500	500	—	—	DD367FDKW	DD367FWKW
	1200	L	—	—	500	500	—	—	DD368FDKW ①	DD368NWKW ①
Four-Wire (Three Blades, Three Fuses, S/N) 480 Vac–600 Vac, 250 Vdc										
	30	H	7.5	10	15	20	—	—	DD361NDKW	DD361NWKW
	60	H	20	25	30	50	—	—	DD362NDKW	DD362NWKW
	100	H	30	40	60	75	—	—	DD363NDKW	DD363NWKW
	200	H	50	50	125	150	—	—	DD364NDKW	DD364NWKW
	400	H	—	—	250	350	—	—	DD365NDKW	DD365NWKW
	600	H	—	—	400	500	—	—	DD366NDKW	DD366NWKW
	800	L	—	—	500	500	—	—	DD367NDKW	DD367NWKW
	1200	L	—	—	500	500	—	—	DD368NDKW ①	DD368NWKW ①

Note

① 1200A is not service entrance rated at 600V.

Modifications

Additions are available such as custom paint, 316-stainless enclosures, custom OEM labeling and more.

Call the Flex Center at 1-888-329-9272 or FlexSwitches@Eaton.com for more information.

Technical Data and Specifications

Ratings and Capacities

Ampere Rating	Factory Fuse Class	Optional Fuse Class ^①	Standard Lug Capacities		Ground ^②	
			Per Phase Min. Wire Size	Max. Wire Size	Min. Wire Size	Max. Wire Size
30	H	J, R	#14	#2	#14	#4
60	H	J, R	#14	#2	#14	#4
100	H	J, R	#14	1/0	#14	#4
200	H	J, R, T	#6	300 kcmil	#14	#2
400	H	J, R, T	(2) 1/0 (1) 1/0	(2) 300 kcmil–1/0 or ^③ (1) 175 kcmil–1/0	#6	250 kcmil
600	H	J, R, T	(1) #2 (1) #2	(1) 600 kcmil and ^④ (1) 750 kcmil	#6	250 kcmil
800	L	T	(4) 1/0	(4) 750 kcmil	#6	250 kcmil
1200	L	T	(4) 1/0	(4) 750 kcmil	#6	250 kcmil

Cable IN/OUT reference chart

	Top IN ^⑤	Bottom IN
Top OUT	■	—
Bottom OUT	■	■

Dimensions

Approximate Dimensions in Inches (mm)

Note: Dimensions are for estimating purposes only.

Heavy-Duty Double Door Safety Switch

Ampere Rating	Height (H)	Width (W)	Depth (D1)	Depth (D2)
30/60	37.49 (952.3)	9.30 (236.2)	8.22 (208.8)	6.37 (161.8)
100	39.19 (995.4)	12.33 (313.2)	10.21 (259.3)	6.37 (161.8)
200	49.90 (1267.5)	17.18 (436.4)	11.62 (295.1)	7.31 (185.7)
400	72.46 (1840.5)	24.32 (617.7)	16.41 (416.8)	14.56 (369.8)
600	77.96 (1980.2)	25.32 (643.1)	19.31 (490.5)	17.80 (452.1)
800	86.73 (2202.9)	26.57 (674.9)	22.16 (562.9)	17.81 (452.4)
1200	91.02 (2312.0)	43.11 (1095.0)	27.18 (690.4)	21.23 (539.2)

Notes

- ① Switches ranging from 30A to 400A can relocate clips/base for class J fuses. All other classes/ampereages require a kit. Please consult catalog or contact the Technical Resource Center (TRC) for specific kit catalog numbers.
- ② Lay-in type lug uses 30–100A. Two ground lugs are provided for 200–1200A switches, each accommodating the wire range listed above.
- ③ Single barrel lug that accepts one or two cables per phase as detailed above.
- ④ Double barrel lug that accepts two cables per phase as detailed above.
- ⑤ Remove wireway in bottom compartment. Necessary for 30–200A units only.

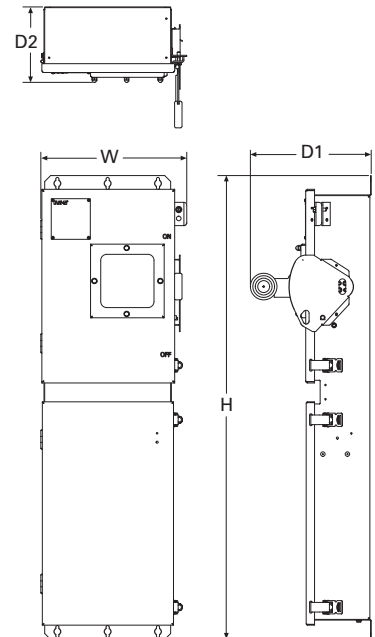

Six-Pole Motor Circuit



Contents

<i>Description</i>	<i>Page</i>
Product Overview	V2-T1-2
General Duty	V2-T1-25
Heavy-Duty	V2-T1-30
Heavy-Duty Double Door Safety Switch	V2-T1-39
Six-Pole Switches	
Product Selection	V2-T1-44
Dimensions	V2-T1-45
Double-Throw Switches	V2-T1-46
EnviroLine Stainless Steel Switch	V2-T1-53
Window Switches	V2-T1-57
Receptacle Switches	V2-T1-60
Non-Metallic KRYDON Switch	V2-T1-62
Shunt Trip Safety Switch	V2-T1-65
NEMA 7/9—Hazardous Location Disconnect Switch	V2-T1-68
Quick-Connect Switches	V2-T1-70
Solar Disconnect Switch	V2-T1-75
Mill-Duty Rated, Heavy-Duty Safety Switch	V2-T1-77
Heavy-Duty Fusible Safety Switches Accepting CUBEFuses	V2-T1-79
Elevator Control Switch	V2-T1-82
Auxiliary Power Heavy-Duty Safety Switch	V2-T1-85
Left-Handed Safety Switch	V2-T1-89
Heavy-Duty Surge Switch	V2-T1-90
OEM Line Isolation (OLI) Switch	V2-T1-92
Pringle Bolted Pressure Switch	V2-T1-95
Type DS, Fusible and Non-Fusible	V2-T1-98
Type Visi-Flex DE-ION	V2-T1-101
Flange Mounted—Variable Depth	V2-T1-105
Flange Mounted—Fixed Depth	V2-T1-109

Six-Pole Switches

Product Description

- 600 Vac, 250 Vdc maximum
- 30–200A UL listed
- 400–800A available, Non-UL listed
- Fusible or non-fusible

Application Description

A compact safety switch that's ideal for use in heavy industry... when an "in sight" disconnecting means is required for two-speed motors that are remote from their motor control devices.

Features, Benefits and Functions

- Trunk-type latches keep the cover tightly closed and a neoprene gasket seals out moisture and dust from the switch assembly
- Visible double-break quick-make, quick-break rotary blade mechanism. Two points of contact provide a positive open and close, easier operation, and also help prevent contact burning for longer contact life
- Clear line shield protection
- Built-in fuse pullers
- Clearly visible handle
- Triple padlocking capability; cabinet door can be further padlocked at the top and bottom

- Deionizing arc chutes; arc chutes confine and suppress the arcs produced by opening contacts under load
- For factory modifications, refer to **Page V2-T1-15**

Standards and Certifications

- UL listed File No. E5239
- UL 98
- NEMA Std KS-1





Seismic Qualifications

- Heavy-duty switches exceed the requirements of Uniform Building Code (UBC) and California Code Title 24 OSP-0011-10, OSP-0012-10



Product Selection

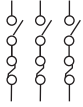

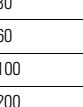
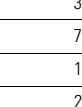
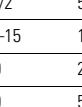
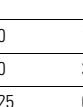
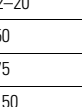
600 Vac Heavy-Duty, Fusible, Six-Pole, Single-Throw

System	Ampere Rating	Fuse Class	Maximum Horsepower Ratings, Three-Phase AC (Higher Rating with Time Delay Fuses)			NEMA 12/3R Enclosure Industrial, Dust-Tight Catalog Number	NEMA 4X Enclosure Corrosion-Resistant, Stainless Steel Catalog Number
			240V	480V	600V		
600 Vac with Fuse Clips—250 Vdc							
	30	H	3–7-1/2	5–15	7-1/2–20	DH661FDK ①②	DH661FWK ②
	60	H	7-1/2–15	15–30	15–50	DH662FDK ①	DH662FWK
	100	H	15–30	25–60	30–75	DH663FDK ①	DH663FWK
	200	H	25–60	50–125	60–150	DH664FDK ①	DH664FWK
	400	H	—	—	—	DH665FDK ③	DH665FWK ③
	600	H	—	—	—	DH666FDK ③	④
	800	L	—	—	—	④	④

DH661UDK

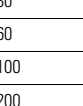
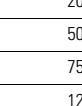
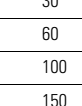
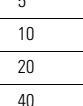
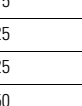

600 Vac Heavy-Duty, Non-Fusible, Six-Pole, Single-Throw

System	Ampere Rating	Maximum Horsepower Ratings					NEMA 12/3R Enclosure Industrial, Dust-Tight Catalog Number	NEMA 4X Enclosure Corrosion-Resistant, Stainless Steel Catalog Number
		Three-Phase AC			Three-Phase DC			
600 Vac—250 Vdc								
	30	10	20	30	5	15	DH661UDK ①	DH661UWK
	60	20	50	60	10	25	DH662UDK ①	DH662UWK
	100	40	75	100	20	25	DH663UDK ①	DH663UWK
	200	60	125	150	40	50	DH664UDK ①	DH664UWK
	400	—	—	—	—	—	DH665UDK ③	DH665UWK ③
	600	—	—	—	—	—	DH666UDK ③	DH666UWK ③
	800	—	—	—	—	—	④	④

Notes

- ① NEMA 12 enclosures (30–800A) can be field modified to meet NEMA 3R rainproof requirements when a factory provided drain hole is opened.
- ② 30A heavy-duty switches with Type J fuse provisions are available from the factory only.
- ③ Non-UL catalog numbers.
- ④ Contact the Safety Switch Flex Center (1-888-329-9272 or FlexSwitches@eaton.com) for availability of this product.
- ⑤ 600 Vdc rating requires that the switch be wired per the wiring diagram on the device publication.

Dimensions

Approximate Dimensions in Inches (mm)

Note: Dimensions are for estimating purposes only.

600 Vac Heavy-Duty, Six-Pole, Single-Throw

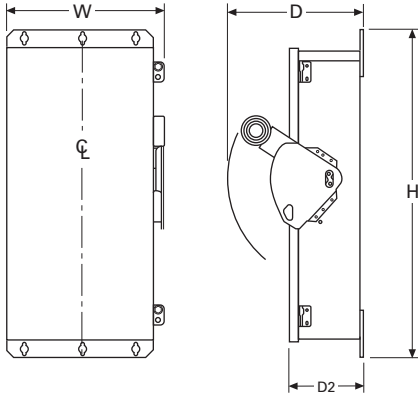

Note: A factory-installed ground lug is supplied in all heavy-duty safety switches.

Six-Pole Switches, Fusible and Non-Fusible

Amperage	NEMA Rating	Height (H)	Width (W)	Depth (D)	Depth (D2)	Weight Lbs (kg)
30A	NEMA 12/3R and 4X	12.17 (309.2)	19.08 (484.6)	10.22 (259.6)	5.50 (139.7)	40 (18.1)
60A	NEMA 12/3R and 4X	12.17 (309.2)	19.08 (484.6)	10.22 (259.6)	5.50 (139.7)	40 (18.1)
100A	NEMA 12/3R and 4X	15.42 (391.7)	24.95 (633.7)	10.22 (259.6)	5.50 (139.7)	45 (20.4)
200A	NEMA 12/3R and 4X	23.51 (597.2)	35.38 (898.7)	11.63 (295.4)	6.44 (163.6)	65 (29.5)

Heavy-Duty Double-Throw



Double-Throw Switches

Product Description

Used to transfer service from a normal power source to an alternate source... or to switch from one load circuit to another.

- 30–1200A
- Horsepower rated
- 600 Vac, 250 Vdc maximum
- 600–1200A fusible utilize common set of fuses as Eaton's stacked double-throw design. The stacked design is suitable for two source 1 load applications only
- 600–800A fusible are available for one source 2 load applications; include an "R" at the end of the catalog number
- Fusible or non-fusible
- Fusible and non-fusible switches are 100% load break and 100% load make rated

- Suitable for service entrance applications unless otherwise noted
- The continuous load current of fusible switches is not to exceed 80% of the rating of fuses employed in other than motor circuits. Non-fusible switches are 100% fully rated
- Wiring configuration from factory allows a single load to be supplied by a normal or alternate source. 30–800A can be field modified to allow two loads to be alternately supplied by a single power source, except for stacked design double-throw switches

Contents

<i>Description</i>	<i>Page</i>
Product Overview	V2-T1-2
General Duty	V2-T1-25
Heavy-Duty	V2-T1-30
Heavy-Duty Double Door Safety Switch	V2-T1-39
Six-Pole Switches	V2-T1-43
Double-Throw Switches	
Features, Benefits and Functions	V2-T1-46
Standards and Certifications	V2-T1-47
Product Selection	V2-T1-47
Technical Data and Specifications	V2-T1-51
Dimensions	V2-T1-51
EnviroLine Stainless Steel Switch	V2-T1-53
Window Switches	V2-T1-57
Receptacle Switches	V2-T1-60
Non-Metallic KRYDON Switch	V2-T1-62
Shunt Trip Safety Switch	V2-T1-65
NEMA 7/9—Hazardous Location Disconnect Switch	V2-T1-68
Quick-Connect Switches	V2-T1-70
Solar Disconnect Switch	V2-T1-75
Mill-Duty Rated, Heavy-Duty Safety Switch	V2-T1-77
Heavy-Duty Fusible Safety Switches Accepting CUBEFuses	V2-T1-79
Elevator Control Switch	V2-T1-82
Auxiliary Power Heavy-Duty Safety Switch	V2-T1-85
Left-Handed Safety Switch	V2-T1-89
Heavy-Duty Surge Switch	V2-T1-90
OEM Line Isolation (OLI) Switch	V2-T1-92
Pringle Bolted Pressure Switch	V2-T1-95
Type DS, Fusible and Non-Fusible	V2-T1-98
Type Visi-Flex DE-ION	V2-T1-101
Flange Mounted—Variable Depth	V2-T1-105
Flange Mounted—Fixed Depth	V2-T1-109

Features, Benefits and Functions

- Ample wire bending space provides for easier installation
- Visible double-break quick-make, quick-break rotary blade mechanism. Two points of contact provide a positive open and close, easier operation, and also help prevent contact burning for longer contact life
- Triple padlocking capability. Personnel safety feature since the large hasp can accommodate up to three 3/8-inch (9.5 mm) shank locks. Clearly visible handle. The position (ON or OFF) can be clearly seen from a distance
- Deionizing arc chutes; arc chutes confine and suppress the arcs produced by opening contacts under load
- Additional locking capability; cabinet door can be further padlocked at the top and bottom
- Clear line shield (provided on fusible double-throw) protects against accidental contact with energized parts. Probe holes enable the user to test if the line side is energized without removing the shield
- Tangential knockouts on sides, top and bottom. Enables any size of conduit to be mounted close to the wall, providing for cable installation closer to the wall and a neat appearance

Standards and Certifications

- UL listed switching neutral capability is available on three-pole and four-pole non-fusible double-throw switches with the installation of the proper bonding kit shown on **Page V2-T1-13**
- Suitable for use as a manually operated switch per 2005 NEC Article 702

- UL listed File No. E5239
- UL 98
- NEMA Std KS-1



Seismic Qualifications

- Heavy-duty switches exceed the requirements of Uniform Building Code (UBC) and California Code Title 24 OSP-0011-10, OSP-0012-10



Product Selection

DT223URH-N Compact Design



240 Vac General-Duty, Non-Fusible, Compact Design, Double-Throw

Ampere Rating Main and Standby	NEMA 3R Enclosure Rainproof Catalog Number	Ampere Rating Main and Standby	NEMA 3R Enclosure Rainproof Catalog Number
Two-Pole—240 Vac		Two-Pole, Three-Wire—240 Vac—Solid Neutral	
30	DT221URH	30	DT221URH-N
60	DT222URH	60	DT222URH-N
100	DT223URH	100	DT223URH-N

DT224URK-NPS



240 Vac General-Duty, Non-Fusible, Compact Design, Double-Throw

Ampere Rating Main and Standby	Maximum Horsepower Ratings						DC 250V	NEMA 3R Enclosure Rainproof Catalog Number
	Single-Phase AC			Three-Phase AC				
	240V	480V	600V	240V	480V	600V		
Two-Pole—240 Vac—250 Vdc								
30	3	—	—	—	—	—	5	DT221URKPS
60	1	—	—	—	—	—	10	DT222URKPS
100	20	—	—	—	—	—	20	DT223URKPS
200	15	—	—	—	—	—	40	DT224URKPS
400	—	—	—	—	—	—	50	DT225URKPS
Two-Pole, Three-Wire—240 Vac—250 Vdc, Solid Neutral								
30	3	—	—	—	—	—	5	DT221URK-NPS
60	10	—	—	—	—	—	10	DT222URK-NPS
100	20	—	—	—	—	—	20	DT223URK-NPS
200	15	—	—	—	—	—	40	DT224URK-NPS
400	—	—	—	—	—	—	50	DT225URK-NPS

240 Vac Heavy-Duty, Fusible, Double-Throw

Ampere Rating Main and Standby	Fuse Class Provision	Maximum Horsepower Ratings with Time Delay Fuses							DC 250V	NEMA 1 Enclosure Indoor Catalog Number	NEMA 3R Enclosure Rainproof Catalog Number	NEMA 12 Enclosure Industrial, Dust-Tight Catalog Number	NEMA 4X Enclosure Corrosion-Resistant Stainless-Steel Catalog Number
		Single-Phase AC			Three-Phase AC								
		240V	480V	600V	240V	480V	600V						
Two-Pole—240 Vac—250 Vdc													
200	H	15	—	—	—	—	—	40	DT224FGK	DT224FRK	—	—	
Three-Pole—240 Vac—250 Vdc													
30	H	3	—	—	7-1/2	—	—	5	DT321FGK	DT321FRK	—	DT321FWK	
60	H	10	—	—	15	—	—	10	DT322FGK	DT322FRK	—	DT322FWK	
100	H	15	—	—	30	—	—	20	DT323FGK	DT323FRK	—	DT323FWK	
200	H	15	—	—	60	—	—	40	DT324FGK	DT324FRK	—	DT324FWK	
400	H	—	—	—	125	—	—	50	DT325FGK	DT325FRK	—	DT325FWK	
600	J	—	—	—	50	—	—	50	DT326FGK ^①	DT326FRK ^①	—	—	
800	L	—	—	—	—	—	—	—	DT327FGK ^①	DT327FRK ^①	—	—	
1200	L	—	—	—	—	—	—	—	DT328FGK	DT328FRK	—	—	

Note

① Available as one source 2 load application by adding "R" to the end of the catalog number.

UL listed switching neutral capability is available on three-pole and four-pole non-fusible double-throw switches with the installation of the proper bonding kit shown on **Page V2-T1-13**. See **Page V2-T1-15** for factory installation from the Flex Center.

DT363FGK



600 Vac Heavy-Duty, Fusible, Double-Throw

Ampere Rating Main and Standby	Fuse Class Provision	Maximum Horsepower Ratings with Time Delay Fuses					NEMA 1 Enclosure Indoor Catalog Number	NEMA 3R Enclosure Rainproof Catalog Number	NEMA 12 Enclosure Industrial, Dust-Tight Catalog Number	NEMA 4X Enclosure Corrosion-Resistant, Stainless Steel Catalog Number
		Single-Phase AC		Three-Phase AC		DC 250V				
		480V	600V	480V	600V					
Three-Pole—600 Vac—250 Vdc										
30	H	7-1/2	10	15	20	—	DT361FGK	②	②	DT361FWK
60	H	20	25	30	50	—	DT362FGK	②	②	DT362FWK
100	H	30	40	60	75	—	DT363FGK	DT363FRK	②	DT363FWK
200	H	50	50	125	150	40	DT364FGK	DT364FRK	②	DT364FWK
400	T	—	—	250	350	50	DT365FGK	DT365FRK	—	DT365FWK
600	J	—	—	—	—	—	DT366FGK ①	DT366FRK ①	—	—
800	L	—	—	—	—	—	DT367FGK ①	DT367FRK ①	—	—
1200	L	—	—	—	—	—	DT368FGK	DT368FRK	—	—

DT363URK



600 Vac Heavy-Duty, Non-Fusible, Double-Throw

Ampere Rating Main and Standby	Maximum Horsepower Ratings					NEMA 1 Enclosure Indoor Catalog Number	NEMA 3R Enclosure Rainproof Catalog Number	NEMA 12 Enclosure Industrial, Dust-Tight Catalog Number	NEMA 4X Enclosure Corrosion-Resistant, Stainless Steel Catalog Number
	Single-Phase AC		Three-Phase AC		DC 250V				
	480V	600V	480V	600V					
Two-Pole—600 Vac—250 Vdc									
30	7-1/2	10	—	—	5	DT261UGK	②	—	—
60	20	25	—	—	10	DT262UGK	②	—	—
100	40	50	—	—	20	DT263UGK	②	—	—
200	50	50	—	—	40	DT264UGK ③	DT264URK ③	—	—
400	—	—	—	—	50	DT265UGK	DT265URK	—	—
600	—	—	—	—	50	DT266UGK	DT266URK	—	—
800	—	—	—	—	50	DT267UGK	DT267URK	—	—
1200	—	—	—	—	50	DT268UGK	DT268URK	—	—
Three-Pole—600 Vac—250 Vdc									
30	7-1/2	10	20	30	5	DT361UGK	DT361URK	DT361UDK ④	DT361UWK
60	20	25	50	60	10	DT362UGK	DT362URK	DT362UDK ④	DT362UWK
100	40	50	75	100	20	DT363UGK	DT363URK	DT363UDK ④	DT363UWK
200	50	50	125	150	40	DT364UGK	DT364URK	DT364UDK ④	DT364UWK
400	—	—	250	350	50	DT365UGK	DT365URK	DT365UDK ④	DT365UWK
600	—	—	250	350	50	DT366UGK	DT366URK	②④	②
800	—	—	250	350	50	DT367UGK	DT367URK	—	—
1200	—	—	250	350	50	DT368UGK	DT368URK	—	—

Notes

- ① Available as one source 2 load application by adding “R” to the end of the catalog number.
 - ② Contact the Safety Switch Flex Center (1-888-329-9272 or FlexSwitches@eaton.com) for availability of this product.
 - ③ Rated 600 Vdc, 50 hp in addition to ratings shown in table.
 - ④ NEMA 12 enclosures (30–1200A) can be field modified to meet NEMA 3R rainproof requirements when a factory provided drain hole is opened.
- UL listed switching neutral capability is available on three-pole and four-pole non-fusible double-throw switches with the installation of the proper bonding kit shown on Page V2-T1-13. See Page V2-T1-15 for factory installation from the Flex Center.

DT363URK



600 Vac Heavy-Duty, Non-Fusible, Double-Throw

Ampere Rating Main and Standby	Maximum Horsepower Ratings				DC	NEMA 1 Enclosure Indoor Catalog Number	NEMA 3R Enclosure Rainproof Catalog Number	NEMA 12 Enclosure Industrial, Dust-Tight Catalog Number	NEMA 4X Enclosure Corrosion-Resistant, Stainless Steel Catalog Number
	Single-Phase AC	Three-Phase AC							
	480V	600V	480V	600V	250V				
Four-Pole—600 Vac—250 Vdc ^①									
30	7-1/2	10	20	30	5	②	DT461URK	②	②
60	20	25	50	60	10	②	DT462URK	②	②
100	40	50	75	100	20	②	DT463URK	②	②
200	—	50	125	150	40		DT464UGK	DT464URK	②
400	—	—	250	350	50		DT465UGK	DT465URK	②
600	—	—	250	350	50		DT466UGK	DT466URK	②
800	—	—	250	350	50		DT467UGK	DT467URK	②
Six-Pole—600 Vac—250 Vdc ^①									
30	7-1/2	10	15	30	5	②	DT661URK	②	②
60	20	25	50	60	10	②	DT662URK	②	②
100	40	50	75	100	20	②	DT663URK	②	②

Notes

- ① Field installable neutral kit is not available. If a neutral is required, order the catalog number shown in the table with "N" suffix.
 - ② Contact the Safety Switch Flex Center (1-888-329-9272 or FlexSwitches@eaton.com) for availability of this product.
- UL listed switching neutral capability is available on three-pole and four-pole non-fusible double-throw switches with the installation of the proper bonding kit shown on **Page V2-T1-13**. See **Page V2-T1-15** for factory installation from the Flex Center.

Technical Data and Specifications

Typical Fusible, Double-Throw Schematic Diagram

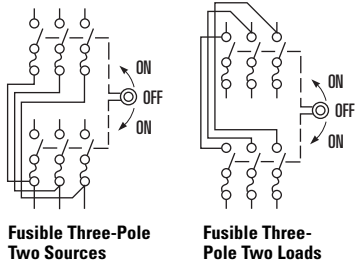

Typical Non-Fusible, Double-Throw Schematic Diagram

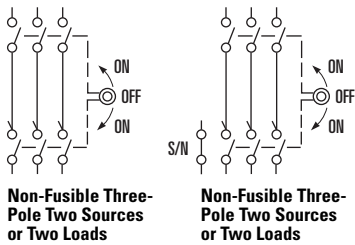

Typical General-Duty, Double-Throw Schematic Diagrams (with and without factory-installed neutral)

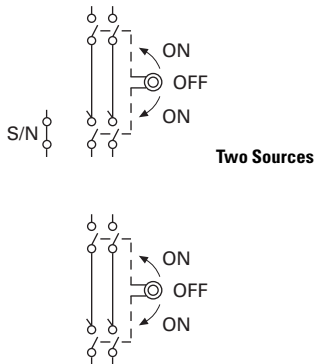

Short-Circuit Ratings Using Class "R", "J", "L" or "T" Fusing Where Applicable

Ampere Rating	Voltage Ratings			
	Type 1	Type 3R	Type 12	Type 4 and 4X
30	100k at 600	100k at 600	100k at 600	100k at 600
60	100k at 600	100k at 600	100k at 600	100k at 600
100	100k at 600	100k at 600	100k at 600	100k at 600
200	100k at 600	100k at 600	100k at 600	100k at 600
400	100k at 600	100k at 600	100k at 600	100k at 600
600	100k at 600	100k at 600	100k at 600	100k at 600
800	100k at 600	100k at 600	—	—
1200	100k at 600	100k at 600	—	—

Dimensions

Approximate Dimensions in Inches (mm)

General-Duty, Non-Fusible, 240V, Two-Pole Solid Neutral, Double-Throw, Compact Design

Ampere Rating	Height (H)	Width (W)	Depth (D)	Depth (D2)	Weight Lbs (kg)
NEMA 3R					
30	14.69 (373.1)	9.63 (244.6)	10.81 (274.6)	5.23 (132.8)	12 (5.5)
60	14.69 (373.1)	9.63 (244.6)	10.81 (274.6)	5.23 (132.8)	12 (5.5)
100	14.69 (373.1)	9.63 (244.6)	10.81 (274.6)	5.23 (132.8)	12 (5.5)

General-Duty, Non-Fusible, 240V, Two-Pole Solid Neutral, Double-Throw, Quick-Make, Quick-Break Design

Ampere Rating	Height (H)	Width (W)	Depth (D)	Depth (D2)	Weight Lbs (kg)
NEMA 3R					
30	24.63 (625.6)	11.94 (303.3)	9.88 (251.0)	5.38 (136.7)	34 (15.4)
60	24.63 (625.6)	11.94 (303.3)	9.88 (251.0)	5.38 (136.7)	34 (15.4)
100	24.63 (625.6)	11.94 (303.3)	9.88 (251.0)	5.38 (136.7)	34 (15.4)
200	37.38 (949.5)	19.56 (496.8)	11.25 (285.8)	6.10 (154.9)	80 (36.3)
400	53.81 (1366.8)	23.13 (587.5)	12.50 (317.6)	8.88 (225.6)	140 (63.6)

NEMA 3R, 30–400A, General-Duty, Non-Fusible, Double-Throw

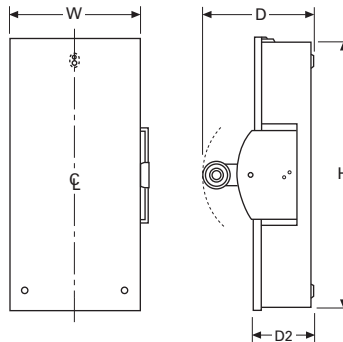

Notes

Class "H" fuse clips supplied as standard for 30–400A except Class "T" for 400A at 600V. Rated at 10,000 rms symmetrical when using Class "H" fuses.

Table is not applicable to the compact design shown on [Page V2-T1-47](#). The compact design is suitable for use on a circuit capable of delivering not more than 10,000 rms symmetrical amperes.

Class "R" fuse adapter kits are shown on [Page V2-T1-13](#). Individual adapter kits are applicable as shown on [Page V2-T1-13](#) and yield the short-circuit ratings per the tables above when Class "R" fuses are installed. When installed, Class "R" fuse adapter kits reject all fuses except Class "R."

Class "J" fuse provisions can be obtained on most 60–400A safety switches by moving the fuse base to a new position as instructed by the device publication label. Class "J" fuse adapter kits, where needed, are shown on [Page V2-T1-13](#) and yield the short-circuit ratings per the tables above when Class "J" fuses are installed. Class "J" fuse provisions must be factory installed on 30A heavy-duty switches. Catalog numbers are shown in table on [Page V2-T1-15](#). Class "J" fusing is not applicable on 30–200A general-duty switches, 30–100A double-throw switches, and any switch higher than 600A.

Class "T" fuse adapter kits are shown on [Page V2-T1-13](#). Individual adapter kits are applicable to 200–800A switches as shown on [Page V2-T1-13](#) and yield the short-circuit ratings per the tables to the left when Class "T" fuses are installed. On 1200A switches, Class "T" fuse provisions can be obtained by moving the fuse base to a new position as instructed by the device publication label.

Approximate Dimensions in Inches (mm)

Heavy-Duty, Non-Fusible, 240V and 600V, Three-Pole, Double-Throw

Ampere Rating	Width (W)	Height (H)	Depth (D)	Depth (D2)	Weight Lbs (kg)
NEMA 1, 3R					
30	11.94 (303.3)	24.63 (625.6)	9.88 (251.0)	5.38 (136.7)	34 (15.436)
60	11.94 (303.3)	24.63 (625.6)	9.88 (251.0)	5.38 (136.7)	34 (15.436)
100	11.94 (303.3)	24.63 (625.6)	9.88 (251.0)	5.38 (136.7)	34 (15.436)
200	19.56 (496.8)	37.38 (949.5)	11.25 (285.8)	6.10 (154.9)	80 (36.32)
400	23.13 (587.5)	53.81 (1366.8)	12.50 (317.5)	7.25 (184.2)	140 (63.56)
600	27.44 (697.0)	63.31 (1608.1)	14.13 (358.9)	8.88 (225.6)	175 (79.45)
800	27.44 (697.0)	63.31 (1608.1)	14.13 (358.9)	8.88 (225.6)	175 (79.45)
1200	42.62 (1082.5)	78.11 (1984.0)	29.62 (752.3)	20.47 (519.9)	473 (214.6)

NEMA 12, 4X Stainless Steel

30	12.00 (304.8)	25.88 (657.4)	10.25 (260.4)	5.50 (139.7)	60 (27.24)
60	12.00 (304.8)	25.88 (657.4)	10.25 (260.4)	5.50 (139.7)	60 (27.24)
100	12.00 (304.8)	25.88 (657.4)	10.25 (260.4)	5.50 (139.7)	60 (27.24)
200	19.50 (495.3)	41.00 (1041.4)	11.63 (295.4)	6.48 (164.6)	105 (47.67)
400	23.00 (584.2)	57.50 (1460.5)	12.50 (317.5)	7.25 (184.2)	185 (83.99)

Heavy-Duty, Fusible, 240V and 600V, Three-Pole, Double-Throw

Ampere Rating	Width (W)	Height (H)	Depth (D)	Depth (D2)	Weight Lbs (kg)
NEMA 1, 3R					
30	11.94 (303.3)	36.63 (930.4)	9.88 (251.0)	5.38 (136.7)	44 (19.976)
60	11.94 (303.3)	36.63 (930.4)	9.88 (251.0)	5.38 (136.7)	44 (19.976)
100	11.94 (303.3)	36.63 (930.4)	9.88 (251.0)	5.38 (136.7)	44 (19.976)
200	19.56 (496.8)	50.88 (1292.4)	11.25 (285.8)	6.10 (154.9)	95 (43.13)
400	25.38 (644.7)	74.75 (1898.7)	14.13 (358.9)	8.88 (225.6)	230 (104.42)
600	28.12 (714.3)	58.86 (1495.0)	25.62 (650.7)	20.47 (520.0)	282 (127.9)
800	28.12 (714.2)	58.86 (1495.0)	25.62 (650.7)	20.47 (519.9)	282 (127.9)
1200	42.62 (1082.5)	78.11 (1984.0)	29.62 (752.3)	20.47 (519.9)	509 (230.9)

NEMA 12, 4X Stainless Steel

30	12.00 (304.8)	39.81 (1011.2)	10.25 (260.4)	5.50 (139.7)	45 (20.43)
60	12.00 (304.8)	39.81 (1011.2)	10.25 (260.4)	5.50 (139.7)	45 (20.43)
100	12.00 (304.8)	39.81 (1011.2)	10.25 (260.4)	5.50 (139.7)	45 (20.43)
200	19.56 (496.8)	55.63 (1413.0)	11.63 (295.4)	6.46 (164.1)	100 (45.4)
400	25.38 (644.7)	74.75 (1898.7)	14.13 (358.9)	8.92 (226.6)	260 (118.04)

NEMA 1, 3R Double-Throw 30-1200A

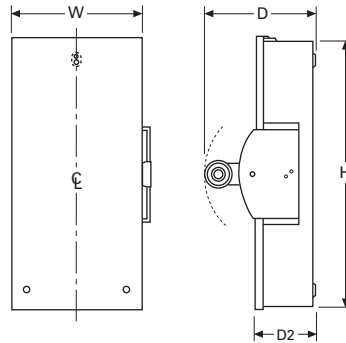

NEMA 12, 4X Double-Throw 30-400A

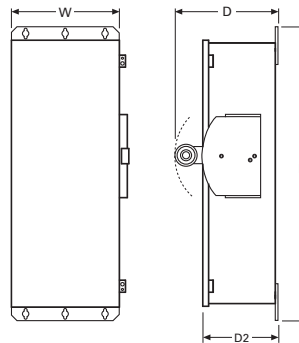

EnviroLine Stainless Steel Switch



Contents

<i>Description</i>	<i>Page</i>
Product Overview	V2-T1-2
General Duty	V2-T1-25
Heavy-Duty	V2-T1-30
Heavy-Duty Double Door Safety Switch	V2-T1-39
Six-Pole Switches	V2-T1-43
Double-Throw Switches	V2-T1-46
EnviroLine Stainless Steel Switch	
Product Selection	V2-T1-54
Dimensions	V2-T1-56
Window Switches	V2-T1-57
Receptacle Switches	V2-T1-60
Non-Metallic KRYDON Switch	V2-T1-62
Shunt Trip Safety Switch	V2-T1-65
NEMA 7/9—Hazardous Location Disconnect Switch	V2-T1-68
Quick-Connect Switches	V2-T1-70
Solar Disconnect Switch	V2-T1-75
Mill-Duty Rated, Heavy-Duty Safety Switch	V2-T1-77
Heavy-Duty Fusible Safety Switches Accepting CUBEFuses	V2-T1-79
Elevator Control Switch	V2-T1-82
Auxiliary Power Heavy-Duty Safety Switch	V2-T1-85
Left-Handed Safety Switch	V2-T1-89
Heavy-Duty Surge Switch	V2-T1-90
OEM Line Isolation (OLI) Switch	V2-T1-92
Pringle Bolted Pressure Switch	V2-T1-95
Type DS, Fusible and Non-Fusible	V2-T1-98
Type Visi-Flex DE-ION	V2-T1-101
Flange Mounted—Variable Depth	V2-T1-105
Flange Mounted—Fixed Depth	V2-T1-109

EnviroLine Stainless Steel Switch

Product Description

Primarily for use in the meat packing and food processing industries or any application where water is frequently used to hose down equipment. In addition to the stainless steel NEMA 4X enclosure, the interior mechanism, backpan and springs are stainless steel. Ratings for these heavy-duty switches are 30–400A, 240–600 Vac, available as fusible and non-fusible switches.

Features

- Stainless steel enclosure (304 grade)
- Stainless steel mechanism (304 grade)
- 30–400A
- Horsepower rated
- Suitable for service entrance use
- Stainless steel back pan (304 grade)
- Stainless steel springs (304 grade)

Standards and Certifications

- Upper and lower window UL 98 listed and NEMA KS-1 approved
- UL 98
- UL listed File No. E5239



Listed

Product Selection

DH321NWKX



240 Vac Heavy-Duty, Fusible, Single-Throw Stainless Steel Enclosure and Operating Mechanism

System	Ampere Rating	Fuse Class Provision	Maximum Horsepower Ratings with Time Delay Fuses				DC 250V	NEMA 4X Enclosure Corrosion-Resistant, Stainless Steel Catalog Number
			AC Standard Fuse		Time Delay			
			Single-Phase	Three-Phase	Single-Phase	Three-Phase		
Three-Wire (Two Blades, Two Fuses, S/N), 240 Vac—250 Vdc								
	30	H	1-1/2	3	3	7-1/2	5	DH221NWKX ^①
	60	H	3	7-1/2	10	15	10	DH222NWKX
	100	H	7-1/2	15	15	30	20	DH223NWKX
	200	H	15	25	15	60	40	DH224NWKX
	400	H	—	50	—	125	50	DH225NWKX
Three-Pole, 240 Vac—250 Vdc (Suitable for Service Entrance Use with a Neutral Kit Installed)								
	30	H	1-1/2	3	—	7-1/2	—	DH321FWKX ^①
	60	H	3	7-1/2	—	15	—	DH322FWKX
	100	H	—	—	—	—	—	②
	200	H	15	25	—	60	40	DH324FWKX
	400	H	—	50	—	125	50	DH325FWKX
Four-Wire (Three Blades, Three Fuses, S/N), 240 Vac—250 Vdc								
	30	H	—	3	—	7-1/2	—	DH321NWKX ^①
	60	H	—	7-1/2	—	15	—	DH322NWKX
	100	H	—	15	—	30	20	DH323NWKX
	200	H	—	25	—	60	—	DH324NWKX
	400	H	—	50	—	125	50	DH325NWKX



Notes

- ① 30A heavy-duty switches with Type J fuse provisions are available from the factory only.
 - ② Contact the Safety Switch Flex Center (1-888-329-9272 or FlexSwitches@eaton.com) for availability of this product.
- See **Page V2-T1-38** for dimensions.

DH361UWKX

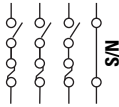

600 Vac Heavy-Duty, Fusible 277/480V, Single-Throw Stainless Steel Enclosure and Operating Mechanism

System	Ampere Rating	Fuse Class Provision	Maximum Horsepower Ratings with Time Delay Fuses						NEMA 4X Enclosure Corrosion-Resistant, Stainless Steel Catalog Number
			Single-Phase AC		Three-Phase AC		DC		
			480V	600V	480V	600V	250V	600V	
Two-Pole, 480 Vac—600 Vac or Vdc ^① (Suitable for Service Entrance Use with a Neutral Kit Installed)									
	30	H	7-1/2	10	—	—	—	15	DH261FWKX ^②
	60	H	—	—	—	—	—	—	^③
	100	H	—	—	—	—	—	—	^③
	200	H	50	50	—	—	—	50	DH264FWKX
	400	H	—	—	—	—	—	—	^③
Three-Pole, 480 Vac—600 Vac, 250 Vdc (Suitable for Service Entrance Use with a Neutral Kit Installed)									
	30	H	7-1/2	10	15	20	—	—	DH361FWKX ^②
	60	H	20	25	30	50	—	—	DH362FWKX
	100	H	30	30	60	75	—	—	DH363FWKX
	200	H	50	50	125	150	—	—	DH364FWKX
	400	H	—	—	250	350	—	—	DH365FWKX
Four-Wire (Three Blades, Three Fuses, S/N) 480 Vac—600 Vac, 250 Vdc									
	30	H	7-1/2	10	20	30	—	—	DH361NWKX ^②
	60	H	20	25	50	60	—	—	DH362NWKX
	100	H	40	50	75	100	—	—	DH363NWKX
	200	H	50	50	125	150	—	—	DH364NWKX
	400	H	—	—	250	350	—	—	DH365NWKX

600 Vac Heavy-Duty, Non-Fusible 277/480V, Single-Throw Stainless Steel Enclosure and Operating Mechanism

System	Ampere Rating	Maximum Horsepower Ratings						NEMA 4X Enclosure Corrosion-Resistant, Stainless Steel Catalog Number
		Single-Phase AC		Three-Phase AC		DC		
		480V	600V	480V	600V	250V	600V	
Three-Pole, 480 Vac—600 Vac, 250 Vdc (Suitable for Service Entrance Use with a Neutral Kit Installed)								
	30	7-1/2	10	20	30	5	—	DH361UWKX
	60	20	25	50	60	10	—	DH362UWKX
	100	40	50	75	100	20	—	DH363UWKX
	200	50	50	125	150	40	—	DH364UWKX
	400	—	—	250	350	50	—	DH365UWKX

Notes

- ^① DC rating for 400A switches is 250V.
 - ^② 30A heavy-duty switches with Type J fuse provisions are available from the factory only.
 - ^③ Contact the Safety Switch Flex Center (1-888-329-9272 or FlexSwitches@eaton.com) for availability of this product.
- See **Page V2-T1-38** for dimensions.

Dimensions

Approximate Dimensions in Inches (mm)

Heavy-Duty, Non-Fusible, 600V, Three-Pole, Single-Throw

Ampere Rating	Width (W)	Height (H)	Depth (D)	Depth (D2)	Weight Lbs (kg)
4X Stainless Steel					
30	8.13 (206.5)	12.13 (308.1)	10.00 (254.0)	5.50 (139.7)	17 (7.718)
60	8.13 (206.5)	12.13 (308.1)	10.00 (254.0)	5.50 (139.7)	17 (7.718)
100	11.13 (282.7)	24.00 (609.6)	10.25 (260.4)	5.50 (139.7)	28 (12.712)
200	16.00 (406.4)	34.38 (873.3)	11.50 (292.1)	6.44 (163.6)	55 (24.97)
400	23.00 (584.2)	57.63 (1463.8)	12.63 (320.8)	7.19 (182.6)	125 (56.75)

Heavy-Duty, Fusible, 240V and 600V, Three-Pole Solid Neutral, Single-Throw

Ampere Rating	Width (W)	Height (H)	Depth (D)	Depth (D2)	Weight Lbs (kg)
4X Stainless Steel					
30	8.13 (206.5)	17.88 (454.2)	10.00 (254.0)	5.50 (139.7)	22 (9.988)
60	8.13 (206.5)	17.88 (454.2)	10.00 (254.0)	5.50 (139.7)	22 (9.988)
100	11.13 (282.7)	24.00 (609.6)	10.25 (260.4)	5.50 (139.7)	30 (13.62)
200	16.00 (406.4)	34.38 (873.3)	11.50 (292.1)	6.44 (163.6)	61 (27.694)
400	23.00 (584.2)	57.63 (1463.8)	12.63 (320.8)	7.19 (182.6)	135 (61.29)

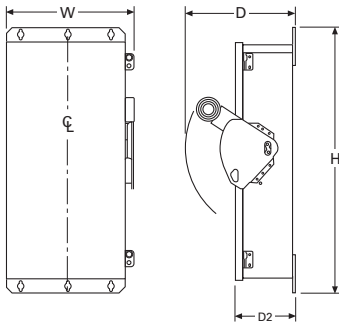
NEMA 4X Heavy-Duty 30–400A

Note: A factory-installed ground lug is supplied in all heavy-duty safety switches.

Window Switch



Contents

<i>Description</i>	<i>Page</i>
Product Overview	V2-T1-2
General Duty	V2-T1-25
Heavy-Duty	V2-T1-30
Heavy-Duty Double Door Safety Switch	V2-T1-39
Six-Pole Switches	V2-T1-43
Double-Throw Switches	V2-T1-46
EnviroLine Stainless Steel Switch	V2-T1-53
Window Switches	
Product Selection	V2-T1-58
Dimensions	V2-T1-59
Receptacle Switches	V2-T1-60
Non-Metallic KRYDON Switch	V2-T1-62
Shunt Trip Safety Switch	V2-T1-65
NEMA 7/9—Hazardous Location Disconnect Switch	V2-T1-68
Quick-Connect Switches	V2-T1-70
Solar Disconnect Switch	V2-T1-75
Mill-Duty Rated, Heavy-Duty Safety Switch	V2-T1-77
Heavy-Duty Fusible Safety Switches Accepting CUBEFuses	V2-T1-79
Elevator Control Switch	V2-T1-82
Auxiliary Power Heavy-Duty Safety Switch	V2-T1-85
Left-Handed Safety Switch	V2-T1-89
Heavy-Duty Surge Switch	V2-T1-90
OEM Line Isolation (OLI) Switch	V2-T1-92
Pringle Bolted Pressure Switch	V2-T1-95
Type DS, Fusible and Non-Fusible	V2-T1-98
Type Visi-Flex DE-ION	V2-T1-101
Flange Mounted—Variable Depth	V2-T1-105
Flange Mounted—Fixed Depth	V2-T1-109

Window Switches

Product Description

All window switches integrate an external viewing window with the enhanced visible blade feature to allow users to easily view the trailing edge of the blades to confirm disconnect is open while the switch is in the OFF position.

Features

- 30–1200A
- Blade visibility when door closed
- Suitable for service entrance use
- NEMA 12, 4 and 4X stainless steel enclosures
- Window material is high-quality laminated safety glass
- External viewing window design is field replaceable—kits available for switches 30–1200A

- 30A and 60A heavy-duty safety switches feature a vertical viewing window
- 100–1200A heavy-duty safety switches feature a horizontal viewing window(s)
- Ratings are 30–1200A, 240–600 Vac, fusible and non-fusible. Available in NEMA 12/3R, 4X stainless steel enclosures

Standards and Certifications

- Upper and lower window UL listed and NEMA KS-1 approved
- UL 98
- UL listed File No. E5239



Seismic Qualifications

- Heavy-duty switches exceed the requirements of Uniform Building Code (UBC) and California Code Title 24 OSP-0011-10, OSP-0012-10



Product Selection

DH361FDKW



240 Vac Heavy-Duty, Fusible Single-Throw with Upper Viewing Window

System	Ampere Rating	Fuse Class Provision	Maximum Horsepower Ratings with Time Delay Fuses				DC 250V	NEMA 12 Enclosure Industrial, Dust-Tight Catalog Number	NEMA 4 Enclosure Watertight, Painted Steel Catalog Number	NEMA 4X Enclosure Corrosion-Resistant, Stainless Steel Catalog Number
			AC Standard Fuse		Time Delay					
			Single-Phase	Three-Phase	Single-Phase	Three-Phase				
Four-Wire (Three Blades, Three Fuses, S/N), 240 Vac—250 Vdc ^①										
	30	H	—	3	—	7-1/2	—	DH321NDKW ^{②③}	—	DH321NWKW ^③
	60	H	—	7-1/2	—	15	—	DH322NDKW ^②	—	DH322NWKW
	100	H	—	15	—	30	20	DH323NDKW ^②	—	DH323NWKW
	200	H	—	25	—	60	—	DH324NDKW ^②	—	DH324NWKW
	400	H	—	50	—	125	50	DH325NDKW ^②	DH325NPKW	DH325NWKW
	600	H	—	75	—	200	—	DH326NDKW ^②	DH326NPKW	DH326NWKW
	800	L	—	100	—	250	—	DH327NDKW ^②	DH327NPKW	DH327NWKW

600 Vac Heavy-Duty, Fusible Single-Throw with Upper Viewing Window

System	Ampere Rating	Fuse Class Provision	Maximum Horsepower Ratings with Time Delay Fuses				DC 250V 600V	NEMA 12 Enclosure Industrial, Dust-Tight Catalog Number	NEMA 4 Enclosure Watertight, Painted Steel Catalog Number	NEMA 4X Enclosure Corrosion-Resistant, Stainless Steel Catalog Number
			Single-Phase AC		Three-Phase AC					
			480V	600V	480V	600V				
Four-Wire (Three Blades, Three Fuses, S/N), 600 Vac—250 Vdc ^①										
	30	H	7-1/2	10	15	20	—	DH361NDKW ^{②③}	—	DH361NWKW ^③
	60	H	20	25	30	50	—	DH362NDKW ^②	—	DH362NWKW
	100	H	30	40	60	75	—	DH363NDKW ^②	—	DH363NWKW
	200	H	50	50	125	150	—	DH364NDKW ^②	—	DH364NWKW
	400	H	—	—	250	350	—	DH365NDKW ^②	DH365NPKW	DH365NWKW
	600	H	—	—	400	500	—	DH366NDKW ^②	DH366NPKW	DH366NWKW
	800	L	—	—	500	500	—	DH367NDKW ^②	DH367NPKW	DH367NWKW
1200	L	—	—	500	500	—	DH368NDKW ^④	—	DH368NWKW ^④	

DH363FWKW



600 Vac Heavy-Duty, Non-Fusible Single-Throw with Upper Viewing Window

System	Ampere Rating	Fuse Class Provision	Maximum Horsepower Ratings with Time Delay Fuses				DC 250V 600V	NEMA 12 Enclosure Industrial, Dust-Tight Catalog Number	NEMA 4 Enclosure Watertight, Painted Steel Catalog Number	NEMA 4X Enclosure Corrosion-Resistant, Stainless Steel Catalog Number
			Single-Phase AC		Three-Phase AC					
			480V	600V	480V	600V				
Three-Pole—600 Vac, 250 Vdc ^① (Suitable for Service Entrance Use with a Neutral Kit Installed)										
	30	7-1/2	10	20	30	5	—	DH361UDKW ^②	—	DH361UWKW
	60	20	25	50	60	10	—	DH362UDKW ^②	—	DH362UWKW
	100	40	50	75	100	20	—	DH363UDKW ^②	—	DH363UWKW
	200	50	50	125	150	40	—	DH364UDKW ^②	—	DH364UWKW
	400	—	—	250	350	50	—	DH365UDKW ^②	DH365UPKW	DH365UWKW
	600	—	—	400	500	—	—	DH366UDKW ^②	DH366UPKW	DH366UWKW
	800	—	—	500	500	—	—	DH367UDKW ^②	DH367UPKW	DH367UWKW
1200	—	—	500	500	—	—	DH368UDKW ^④	—	DH368UWKW ^④	

Notes

- ① For two-pole applications, use outside poles of three-pole switch.
- ② NEMA 12 enclosures (30–1200A) can be field modified to meet NEMA 3R rainproof requirements when a factory provided drain hole is opened.
- ③ 30A heavy-duty switches with Type J fuse provisions are available from the factory only.
- ④ NOT suitable for use as service entrance per NEC 215.10 and 230.95.

240 Vac Heavy-Duty, Fusible, Single-Throw with Lower Viewing Window ①

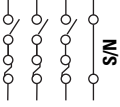
System	Ampere Rating	Fuse Class Provision	Maximum Horsepower Ratings with Time Delay Fuses AC					DC 250V	NEMA 12/3R Enclosure Industrial, Dust-Tight Catalog Number	NEMA 4 Enclosure Watertight, Painted Steel Catalog Number	NEMA 4X Enclosure Corrosion-Resistant, Stainless Steel Catalog Number	
			Standard Fuse		Time Delay		Single-Phase					Three-Phase
			Single-Phase	Three-Phase	Single-Phase	Three-Phase						
Four-Wire (Three Blades, Three Fuses, S/N), 240 Vac—250 Vdc ②												
	200	H	—	25	—	60	—	DH324NDKLW ③	—	DH324NWKLW		
	400	H	—	50	—	125	50	DH325NDKLW ③	DH325NPKLW	DH325NWKLW		
	600	H	—	75	—	200	—	DH326NDKLW ③	DH326NPKLW	DH326NWKLW		
	800	L	—	100	—	250	—	DH327NDKLW ③	DH327NPKLW	DH327NWKLW		
	1200	L	—	—	—	—	—	DH328NDKLW ③	DH328NPKLW	DH328NWKLW		

600 Vac Heavy-Duty, Fusible, Single-Throw with Lower Viewing Window ①

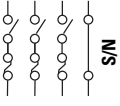
System	Ampere Rating	Fuse Class Provision	Maximum Horsepower Ratings with Time Delay Fuses						NEMA 12/3R Enclosure Industrial, Dust-Tight Catalog Number	NEMA 4 Enclosure Watertight, Painted Steel Catalog Number	NEMA 4X Enclosure Corrosion-Resistant, Stainless Steel Catalog Number
			Single-Phase AC			Three-Phase AC					
			480V	600V	480V	600V	480V	600V			
Four-Wire (Three Blades, Three Fuses, S/N), 600 Vac—250 Vdc ②											
	200	H	50	50	125	150	—	DH364NDKLW ③	—	DH364NWKLW	
	400	H	—	—	250	350	—	DH365NDKLW ③	DH365NPKLW	DH365NWKLW	
	600	H	—	—	400	500	—	DH366NDKLW ③	DH366NPKLW	DH366NWKLW	
	800	L	—	—	500	500	—	DH367NDKLW ③	DH367NPKLW	DH367NWKLW	
	1200	L	—	—	500	500	—	DH368NDKLW ③④	DH368NPKLW ④	DH368NWKLW ④	

Dimensions

Approximate Dimensions in Inches (mm)

Heavy-Duty, Fusible and Non-Fusible with Window

Heavy-Duty, Non-Fusible, 600V, Three-Pole, Single-Throw

Ampere Rating	Width (W)	Height (H)	Depth (D)	Depth (D2)	Weight Lbs (kg)
NEMA 12/3R, 4, 4X Stainless Steel					
30	8.76 (222.5)	19.08 (484.6)	10.22 (259.6)	5.50 (139.7)	22 (9.988)
60	8.76 (222.5)	19.08 (484.6)	10.22 (259.6)	5.50 (139.7)	22 (9.988)
100	11.79 (299.5)	24.95 (633.7)	10.22 (259.6)	5.50 (139.7)	30 (13.62)
200	16.95 (430.5)	35.38 (898.7)	11.63 (295.4)	6.44 (163.6)	61 (27.694)
400	24.12 (612.6)	57.47 (1459.7)	12.43 (315.7)	7.19 (182.6)	135 (61.29)
600	25.01 (635.3)	62.97 (1599.4)	12.79 (324.9)	8.95 (227.3)	203 (92.162)
800	26.35 (669.3)	71.72 (1821.7)	12.79 (324.9)	8.95 (227.3)	213 (96.702)
1200	43.11 (1095.0)	73.77 (1873.8)	17.15 (435.6)	12.45 (316.2)	510 (231.54)

NEMA 12/3R, 4, 4X Heavy-Duty 30–1200A

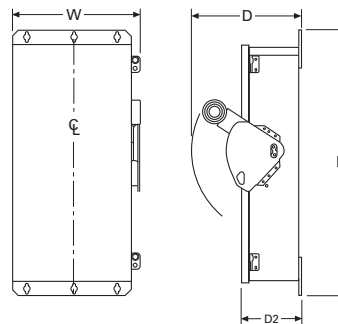

Note: A factory-installed ground lug is supplied in all heavy-duty safety switches.

Notes

- ① Lower windows are only available for 200–1200A switches.
- ② For two-pole applications, use outside poles of three-pole switch.
- ③ NEMA 12 enclosures (30–1200A) can be field modified to meet NEMA 3R rainproof requirements when a factory provided drain hole is opened.
- ④ Not suitable for service entrance per NEC 215.10 and 230.95.

Receptacle Switch



Receptacle Switches

Product Description

These heavy-duty switches are pre-wired and interlocked to polarized receptacles for three-phase, three-wire, grounded type power plugs. Receptacles are interlocked to handle mechanisms so that power plugs may not be inserted or removed when the switch is in the ON position unless noted otherwise. Ratings are 30–100A, 600 Vac, NEMA 12/3R, 4X stainless steel enclosures.

- 30–100A
- Power plugs not supplied with the receptacle
- Can be supplied with viewing windows

Application Description

These are used for portable power applications such as welders, infrared ovens, batch feeders, conveyors, truck and marine docks.

Contents

<i>Description</i>	<i>Page</i>
Product Overview	V2-T1-2
General Duty	V2-T1-25
Heavy-Duty	V2-T1-30
Heavy-Duty Double Door Safety Switch	V2-T1-39
Six-Pole Switches	V2-T1-43
Double-Throw Switches	V2-T1-46
EnviroLine Stainless Steel Switch	V2-T1-53
Window Switches	V2-T1-57
Receptacle Switches	
Product Selection	V2-T1-61
Non-Metallic KRYDON Switch	V2-T1-62
Shunt Trip Safety Switch	V2-T1-65
NEMA 7/9—Hazardous Location Disconnect Switch	V2-T1-68
Quick-Connect Switches	V2-T1-70
Solar Disconnect Switch	V2-T1-75
Mill-Duty Rated, Heavy-Duty Safety Switch	V2-T1-77
Heavy-Duty Fusible Safety Switches Accepting CUBEFuses	V2-T1-79
Elevator Control Switch	V2-T1-82
Auxiliary Power Heavy-Duty Safety Switch	V2-T1-85
Left-Handed Safety Switch	V2-T1-89
Heavy-Duty Surge Switch	V2-T1-90
OEM Line Isolation (OLI) Switch	V2-T1-92
Pringle Bolted Pressure Switch	V2-T1-95
Type DS, Fusible and Non-Fusible	V2-T1-98
Type Visi-Flex DE-ION	V2-T1-101
Flange Mounted—Variable Depth	V2-T1-105
Flange Mounted—Fixed Depth	V2-T1-109

Standards and Certifications

- UL 98 listed NEMA approved
- NEMA KS-1 approved
- UL listed File No. E5239



Note: For Cam-Lok and Posi-Lok style receptacles, see Eaton's Quick Connect Switch.

Seismic Qualifications

- Heavy-duty switches exceed the requirements of Uniform Building Code (UBC) and California Code Title 24 OSP-0011-10, OSP-0012-10



Product Selection

600 Vac Heavy-Duty, Single-Throw with Receptacle, Fusible, Non-Fusible

DH362FDK2WR



Safety Switch with Receptacle K-Series, Three-Pole, 600 Volt Fuse Clips—Fusible

Ampere Rating			NEMA 12/3R Enclosure	NEMA 12/3R Enclosure with Window	NEMA 4X Enclosure	NEMA 4X Enclosure with Window
Switch	Receptacle	Power Plug	Catalog Number	Catalog Number	Catalog Number	Catalog Number
Crouse-Hinds ARKTITE® Receptacle						
		Accepts Crouse-Hinds®				
30	30	APJ3485	DH361FDK2WR	DH361FDK2WRW	DH361FWK2WR	DH361FWK2WRW
60	60	APJ6485	DH362FDK2WR	DH362FDK2WRW	DH362FWK2WR	DH362FWK2WRW
100	100	APJ10487	DH363FDK2WR	DH363FDK2WRW	DH363FWK2WR	DH363FWK2WRW
M-R-S (Russellstoll) MAX-GARD® Receptacle						
		Accepts Russellstoll				
30	30	DS3404MP	DH361FD3WRK	DH361FD3WRKW	DH361FW3WRK	DH361FW3WRKW
60	60	DS6404MP	DH362FD3WRK	DH362FD3WRKW	DH362FW3WRK	DH362FW3WRKW
100	100	DS1404MP	DH363FD3WRK	DH363FD3WRKW	DH363FW3WRK	DH363FW3WRKW
Appleton POWERTITE® Receptacle						
		Accepts Appleton				
30	30	ACP3034BC	DH361FD5WRK	DH361FD5WRKW	DH361FW5WRK	DH361FW5WRKW
60	60	ACP6034BC	DH362FD5WRK	DH362FD5WRKW	DH362FW5WRK	DH362FW5WRKW
100	100	ACP1034CD	DH363FD5WRK	DH363FD5WRKW	DH363FW5WRK	DH363FW5WRKW

Safety Switch with Receptacle K-Series, Three-Pole, 600 Volt Fuse Clips—Non-Fusible

Ampere Rating			NEMA 12/3R Enclosure	NEMA 12/3R Enclosure with Window	NEMA 4X Enclosure	NEMA 4X Enclosure with Window
Switch	Receptacle	Power Plug	Catalog Number	Catalog Number	Catalog Number	Catalog Number
Crouse-Hinds ARKTITE Receptacle						
		Accepts Crouse-Hinds				
60	60	APJ6485	DH362UDK2WR	DH362UDK2WRW	DH362UWK2WR	DH362UWK2WRW
Appleton POWERTITE Receptacle						
		Accepts Appleton				
30	30	ACP3034BC	DH361UD5WRK	DH361UD5WRKW	DH361UW5WRK	DH361UW5WRKW
60	60	ACP6034BC	DH362UD5WRK	DH362UD5WRKW	DH362UW5WRK	DH362UW5WRKW

Notes

Contact the Safety Switch Flex Center (1-888-329-9272 or FlexSwitches@eaton.com) for additional options including viewing windows and other receptacle manufacturers. Power plugs are not available through Eaton.

Non-Metallic KRYDON Switch



Non-Metallic KRYDON Switch

Product Description

This switch has a KRYDON™ enclosure. These are compression molded fiberglass reinforced polyester enclosure, which is capable of withstanding almost any corrosive environment. Ratings are 30–200A, 240–600 Vac, fusible and non-fusible. Enclosure is NEMA 4X rated.

Features

- 30–200A
- KRYDON high-impact strength fiberglass reinforced polyester material
- Horsepower rated
- Suitable for service entrance use
- Fusible and non-fusible
- Stainless steel external hardware

Contents

<i>Description</i>	<i>Page</i>
Product Overview	V2-T1-2
General Duty	V2-T1-25
Heavy-Duty	V2-T1-30
Heavy-Duty Double Door Safety Switch	V2-T1-39
Six-Pole Switches	V2-T1-43
Double-Throw Switches	V2-T1-46
EnviroLine Stainless Steel Switch	V2-T1-53
Window Switches	V2-T1-57
Receptacle Switches	V2-T1-60
Non-Metallic KRYDON Switch	
Product Selection	V2-T1-63
Dimensions	V2-T1-64
Shunt Trip Safety Switch	V2-T1-65
NEMA 7/9—Hazardous Location Disconnect Switch	V2-T1-68
Quick-Connect Switches	V2-T1-70
Solar Disconnect Switch	V2-T1-75
Mill-Duty Rated, Heavy-Duty Safety Switch	V2-T1-77
Heavy-Duty Fusible Safety Switches Accepting CUBEFuses	V2-T1-79
Elevator Control Switch	V2-T1-82
Auxiliary Power Heavy-Duty Safety Switch	V2-T1-85
Left-Handed Safety Switch	V2-T1-89
Heavy-Duty Surge Switch	V2-T1-90
OEM Line Isolation (OLI) Switch	V2-T1-92
Pringle Bolted Pressure Switch	V2-T1-95
Type DS, Fusible and Non-Fusible	V2-T1-98
Type Visi-Flex DE-ION	V2-T1-101
Flange Mounted—Variable Depth	V2-T1-105
Flange Mounted—Fixed Depth	V2-T1-109

Standards and Certifications

- UL 98 listed File No. E5239



Seismic Qualifications

- Heavy-duty switches exceed the requirements of Uniform Building Code (UBC) and California Code Title 24 OSP-0011-10, OSP-0012-10



Product Selection

DH361UCK



240 Vac Heavy-Duty Non-Metallic Fusible

System	Ampere Rating	Fuse Class Provision	Maximum Horsepower Ratings				DC 250V	NEMA 4X Enclosure Corrosion-Resistant, Non-Metallic Catalog Number
			AC		Time Delay			
			Standard Fuse Single-Phase	Three-Phase	Single-Phase	Three-Phase		
Three-Pole, 240 Vac—250 Vdc (Suitable for Service Entrance Use with a Neutral Kit Installed)								
	30	H	1-1/2	3	—	7-1/2	—	DH321FCK ①
	60	H	3	7-1/2	—	15	—	DH322FCK
	100	H	7-1/2	15	—	30	20	DH323FCK
	200	H	15	25	—	60	40	DH324FCK
Four-Wire (Three Blades, Three Fuses, S/N), 240 Vac—250 Vdc								
	30	H	—	3	—	7-1/2	—	DH321NCK ①
	60	H	—	7-1/2	—	15	—	DH322NCK
	100	H	—	15	—	30	20	DH323NCK
	200	H	—	25	—	60	—	DH324NCK

600 Vac Heavy-Duty Non-Metallic Fusible

System	Ampere Rating	Fuse Class Provision	Maximum Horsepower Ratings with Time Delay Fuses						NEMA 4X Enclosure Corrosion-Resistant, Non-Metallic Catalog Number
			Single-Phase AC		Three-Phase AC		DC		
			480V	600V	480V	600V	250V	600V	
Three-Pole, 480 Vac—600 Vac, 250 Vdc (Suitable for Service Entrance Use with a Neutral Kit Installed)									
	30	H	7-1/2	10	15	20	—	—	DH361FCK ①
	60	H	20	25	30	50	—	—	DH362FCK
	100	H	30	30	60	75	—	—	DH363FCK
	200	H	50	50	125	150	—	—	DH364FCK
Four-Wire (Three Blades, Three Fuses, S/N), 480 Vac—600 Vac, 250 Vdc									
	30	H	7-1/2	10	15	20	—	—	DH361NCK ①
	60	H	20	25	30	50	—	—	DH362NCK
	100	H	30	30	60	75	—	—	DH363NCK
	200	H	50	50	125	150	—	—	DH364NCK

600 Vac Heavy-Duty Non-Metallic Non-Fusible 277/480–600V

System	Ampere Rating	Maximum Horsepower Ratings with Time Delay Fuses						DC 250V 600V	NEMA 4X Enclosure Corrosion-Resistant, Non-Metallic Catalog Number	
		Single-Phase AC			Three-Phase AC					
		240V	480V	600V	240V	480V	600V			
Three-Pole, 480 Vac—600 Vac, 250 Vdc (Suitable for Service Entrance Use with a Neutral Kit Installed)										
	30	3	7-1/2	10	10	20	30	5	—	DH361UCK
	60	10	20	25	20	50	60	10	—	DH362UCK
	100	20	40	50	40	75	100	20	—	DH363UCK
	200	15	50	50	60	125	150	40	—	DH364UCK

Note

① 30A heavy-duty switches with Type J fuse provisions are available from the factory only.

1.1

Switching Devices

Safety Switches

1

Dimensions

Approximate Dimensions in Inches (mm)

Note: Dimensions are for estimating purposes only.

240 Vac and 600 Vac Heavy-Duty Non-Metallic

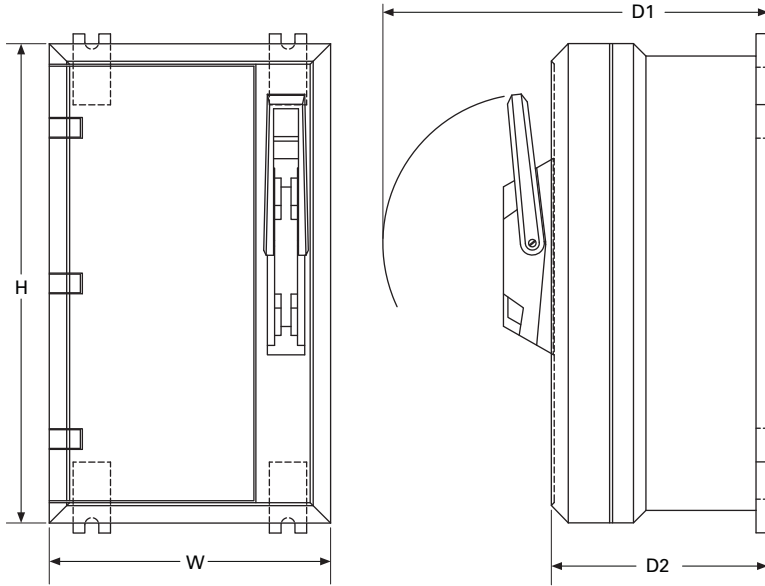

Non-Metallic NEMA 4X Rated Safety Switches, Fusible and Non-Fusible

Amperage	Height Height (H)	Width Width (W)	Depth Depth (D1)	Depth Depth (D2)	Weight Lbs (kg)
30A	19.25 (489.0)	11.30 (287.0)	15.46 (392.7)	8.63 (219.2)	32 (14.5)
60A	19.25 (489.0)	11.30 (287.0)	15.46 (392.7)	8.63 (219.2)	32 (14.5)
100A	27.25 (692.2)	15.30 (388.6)	16.46 (418.1)	9.70 (246.4)	45 (20.4)
200A	27.25 (692.2)	25.30 (642.6)	16.46 (418.1)	9.70 (246.4)	77 (35.0)

Shunt Trip Safety Switch



Shunt Trip Safety Switch

Product Description

Eaton's tried and true heavy-duty safety switch line expands to include shunt trip capability—remote switching and visible means of disconnect for commercial and industrial applications.

The shunt trip technology enhances safety by providing a means to open a safety switch electronically. When using an emergency stop, safety interlock or similar means, the remote operation capability of the shunt trip switch no longer requires personnel to manually open the switch with the handle, enhancing safety and improving productivity.

The shunt trip safety switch builds on Eaton's extensive portfolio of safety switch solutions, incorporating a side-handle operation mechanism and visible blade indication that have decades of successful installation and operation.

Contents

Description

	<i>Page</i>
Product Overview	V2-T1-2
General Duty	V2-T1-25
Heavy-Duty	V2-T1-30
Heavy-Duty Double Door Safety Switch	V2-T1-39
Six-Pole Switches	V2-T1-43
Double-Throw Switches	V2-T1-46
EnviroLine Stainless Steel Switch	V2-T1-53
Window Switches	V2-T1-57
Receptacle Switches	V2-T1-60
Non-Metallic KRYDON Switch	V2-T1-63
Shunt Trip Safety Switch	
Options	V2-T1-66
Standards and Certifications	V2-T1-66
Catalog Number Selection	V2-T1-66
Technical Data and Specifications	V2-T1-67
Dimensions	V2-T1-67
NEMA 7/9—Hazardous Location Disconnect Switch	V2-T1-68
Quick-Connect Switches	V2-T1-70
Solar Disconnect Switch	V2-T1-75
Mill-Duty Rated, Heavy-Duty Safety Switch	V2-T1-77
Heavy-Duty Fusible Safety Switches Accepting CUBEFuses	V2-T1-79
Elevator Control Switch	V2-T1-82
Auxiliary Power Heavy-Duty Safety Switch	V2-T1-85
Left-Handed Safety Switch	V2-T1-89
Heavy-Duty Surge Switch	V2-T1-90
OEM Line Isolation (OLI) Switch	V2-T1-92
Pringle Bolted Pressure Switch	V2-T1-95
Type DS, Fusible and Non-Fusible	V2-T1-98
Type Visi-Flex DE-ION	V2-T1-101
Flange Mounted—Variable Depth	V2-T1-105
Flange Mounted—Fixed Depth	V2-T1-109

Application Description

The shunt trip safety switch can be configured to meet the needs of safety applications in industrial and commercial environments. The switches can be signaled to electronically operate the trip mechanism and interrupt the flow of power when a defined electrical condition is detected via protection relay (for example, ground fault, undervoltage, blown fuse shutdown).

Application Examples

- E-stop
- Safety interlocking
- Machinery OEM interlocking
- Remote opening (distant from switch)
- Cost-effective solution for high-interrupt applications
- Ground fault ①
- Phase reversal / phase loss ①
- Blown fuse shutdown ①
- Undervoltage release ①

Note

① Shunt trip switch provides solenoid/coil to facilitate shunt trip, specific relay and applicable power supply provided by others.

1.1

Switching Devices

Safety Switches

1

Features

- Variety of coil voltages available
- Visible means of disconnect
- Standard heavy-duty safety switch design with integrated shunt trip module
- Passes Class 1 ground fault testing (1200% opening)
- 30–800 A (240–600 Vac)
- Horsepower ratings are the same as Eaton's standard heavy-duty safety switches
- Fusible devices have short-circuit ratings of up to 200 kAIC

Options

Flex Center modifications available, such as viewing windows, pilot lights and more.

Auxiliary contacts **MUST** be factory installed. No auxiliary contacts are available for field installation.

Standards and Certifications

- UL 98 file number E5239 (600 Vac maximum)
- CSA C22.2 No. 4, file number LL69743 (600 Vac maximum)
- Enclosure ratings: NEMA 12/3R, 4 (painted steel), 4X (stainless steel)



Catalog Number Selection

Shunt Trip Safety Switch

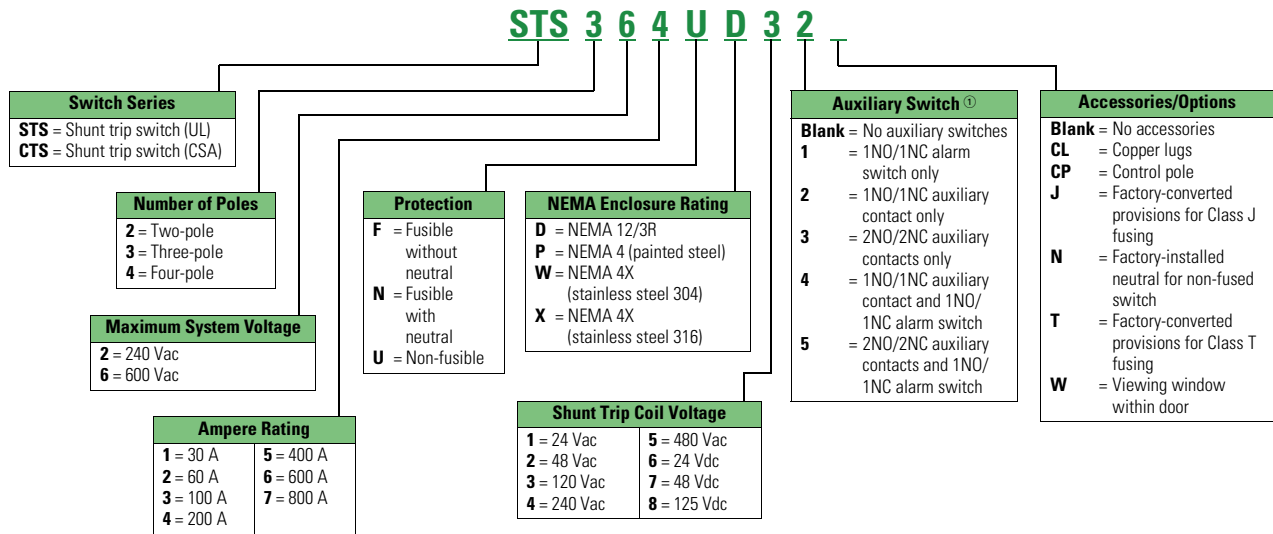

Note

- ① Auxiliary switches must be specified and ordered up front in the catalog number as a factory installed option. Auxiliary switch field kits (DS200EK1 and DS200EK2) can not be field installed on shunt trip switches.

Technical Data and Specifications

Shunt Trip Safety Switch—240 Vac and 600 Vac—Ratings

Ampere Rating	Fuse Class ^①	Number of Poles
Fusible		
30	H	2, 3 or 4 ^②
60	H	2, 3 or 4 ^②
100	H	2, 3 or 4 ^②
200	H	2, 3 or 4
400	H	2, 3 or 4
600	H	2, 3
800	L	2, 3
Non-Fusible		
30	—	2, 3 or 4 ^②
60	—	2, 3 or 4 ^②
100	—	2, 3 or 4 ^②
200	—	2, 3 or 4
400	—	2, 3 or 4
600	—	2, 3
800	—	2, 3

Terminal/Lug Wire Range

Ampere Rating	Minimum—Maximum	Wire Type
30	#14–#2	Cu/Al
60	#14–#2	Cu/Al
100	#14–1/0	Cu/Al
200	#6–300 kcmil	Cu/Al
400	(2) 1/0–300 kcmil or (1) 1/0–750 kcmil	Cu/Al
600	(1) #2–600 kcmil and (1) 1/0–750 kcmil	Cu/Al
800	(4) 1/0–750 kcmil	Cu/Al

Dimensions

Approximate Dimensions in Inches (mm)

Shunt Trip Safety Switch—240 Vac and 600 Vac

Ampere Rating	Enclosure Dimensions ^③ , Exterior			
	Height (H)	Width (W)	Depth (D ₁)	Depth (D ₂)
Fusible				
30	21.58 (548.1)	11.58 (294.1)	11.43 (290.3)	5.58 (141.7)
60	21.58 (548.1)	11.58 (294.1)	11.43 (290.3)	5.58 (141.7)
100	24.95 (633.7)	14.89 (378.2)	11.51 (282.4)	5.58 (141.7)
200	35.38 (898.7)	20.11 (510.8)	11.61 (294.9)	6.45 (163.8)
400	57.47 (1459.7)	27.29 (693.2)	12.43 (315.7)	7.42 (188.5)
600	62.97 (1599.4)	28.29 (718.6)	12.43 (315.7)	7.42 (188.5)
800	71.72 (1821.7)	29.54 (750.3)	12.43 (315.7)	7.42 (188.5)
Non-Fusible				
30	21.58 (548.1)	11.58 (294.1)	11.43 (290.3)	5.58 (141.7)
60	21.58 (548.1)	11.58 (294.1)	11.43 (290.3)	5.58 (141.7)
100	24.95 (633.7)	14.89 (378.2)	11.51 (282.4)	5.58 (141.7)
200	35.38 (898.7)	20.11 (510.8)	11.61 (294.9)	6.45 (163.8)
400	57.47 (1459.7)	27.29 (693.2)	12.43 (315.7)	7.42 (188.5)
600	62.97 (1599.4)	28.29 (718.6)	12.43 (315.7)	7.42 (188.5)
800	71.72 (1821.7)	29.54 (750.3)	12.43 (315.7)	7.42 (188.5)

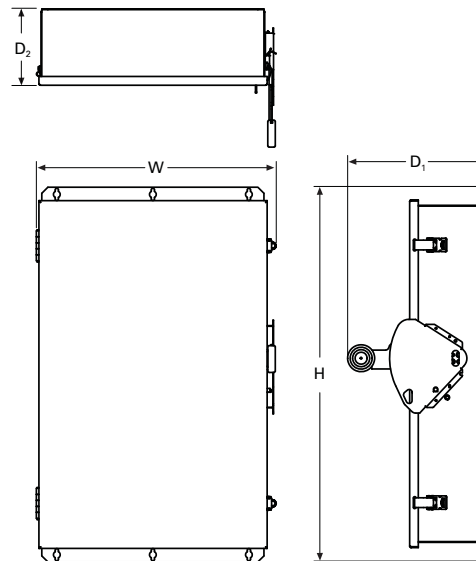

Notes

- ① Class H fuse clips supplied as standard on fusible devices 30–600 A, Class L for 800 A; Class R, J, T fuse clips available.
 - ② Four-pole devices are wider than dimension for 30, 60 and 100 A devices. Consult factory for details.
 - ③ Accurate for all enclosure NEMA type ratings—12/3R, 4, 4X stainless steel.
- For additional technical information, please refer to Technical Data TD008003EN.

DS361UX



Contents

<i>Description</i>	<i>Page</i>
Product Overview	V2-T1-2
General Duty	V2-T1-25
Heavy-Duty	V2-T1-30
Heavy-Duty Double Door Safety Switch	V2-T1-39
Six-Pole Switches	V2-T1-43
Double-Throw Switches	V2-T1-46
EnviroLine Stainless Steel Switch	V2-T1-53
Window Switches	V2-T1-57
Receptacle Switches	V2-T1-60
Non-Metallic KRYDON Switch	V2-T1-62
Shunt Trip Safety Switch	V2-T1-65
NEMA 7/9—Hazardous Location Disconnect Switch	
Product Selection	V2-T1-69
Dimensions	V2-T1-69
Quick-Connect Switches	V2-T1-70
Solar Disconnect Switch	V2-T1-75
Mill-Duty Rated, Heavy-Duty Safety Switch	V2-T1-77
Heavy-Duty Fusible Safety Switches Accepting	
CUBEFuses	V2-T1-79
Elevator Control Switch	V2-T1-82
Auxiliary Power Heavy-Duty Safety Switch	V2-T1-85
Left-Handed Safety Switch	V2-T1-89
Heavy-Duty Surge Switch	V2-T1-90
OEM Line Isolation (OLI) Switch	V2-T1-92
Pringle Bolted Pressure Switch	V2-T1-95
Type DS, Fusible and Non-Fusible	V2-T1-98
Type Visi-Flex DE-ION	V2-T1-101
Flange Mounted—Variable Depth	V2-T1-105
Flange Mounted—Fixed Depth	V2-T1-109

NEMA 7/9—Hazardous Location Disconnect Switch

Product Description

Eaton’s Type DS switch is used as the switching device. Ratings are 30–100A, 600 Vac, fusible and non-fusible.

Features

- 30–100A
- 600 Vac fusible and non-fusible

Application Description

The cast aluminum enclosure is ideally suited for harsh industrial applications including petrochemical facilities, mining operations, pharmaceutical plants and wastewater treatment facilities.

Standards and Certifications

- UL 98
- UL listed File No. E5239

Compliances

UL Classified— Standard 886 File No. E84577	CSA Certified— Standard C22.2 File No. LR 42131-6
Class I, Division 1 and 2, Groups B, C and D	Class I, Division 1 and 2, Groups B, C and D
Class II, Division 1 and 2, Groups E, F and G	Class II, Division 1 and 2, Groups E, F and G
Class III, Division 1 and 2	Class III, Division 1 and 2
NEMA 7/9	NEMA 7/9
Zone 1, IIB + H ₂	Zone 1, IIB + H ₂



Product Selection

DS361UX



NEMA 7/9 Enclosure Sizes—Fusible

Ampere Rating	Maximum Horsepower Ratings			Fuse Class Provision	Number of Poles	Voltage	Enclosure Number	Catalog Number
	Three-Phase AC 480V	600V	DC 250V					
30	15	20	5	J	3	600 Vac, 125/250 Vdc	1	DS361FX
60	30	50	10	J	3	600 Vac, 125/250 Vdc	2	DS362FX
100	60	75	20	J	3	600 Vac, 125/250 Vdc	3	DS363FX

NEMA 7/9 Enclosure Sizes—Non-Fusible

Ampere Rating	Maximum Horsepower Ratings			Fuse Class Provision	Number of Poles	Voltage	Enclosure Number	Catalog Number
	Three-Phase AC 480V	600V	DC 250V					
30	15	20	5	—	3	600 Vac, 125/250 Vdc	1	DS361UX
60	30	50	10	—	3	600 Vac, 125/250 Vdc	1	DS362UX
100	60	75	20	—	3	600 Vac, 125/250 Vdc	2	DS363UX

Dimensions

Approximate Dimensions in Inches (mm)

NEMA 7/9 Enclosure Sizes ①

Dimension	Non-Fusible Disconnect Switch			Fusible Disconnect Switch		
	Catalog Number DS361UX	DS362UX	DS363UX	Catalog Number DS361FX	DS362FX	DS363FX
A	9.74 (247.0)	9.90 (251.0)	10.28 (261.0)	10.02 (255.0)	9.90 (251.0)	10.40 (264.0)
B	5.00 (127.0)	7.00 (178.0)	9.00 (229.0)	7.00 (178.0)	7.00 (178.0)	15.00 (380.0)
C	10.47 (266.0)	12.53 (318.0)	14.67 (373.0)	12.67 (322.0)	12.53 (318.0)	17.31 (440.0)
D	11.13 (283.0)	15.13 (384.0)	17.13 (435.0)	13.13 (333.0)	15.13 (384.0)	11.50 (292.0)
E	12.47 (317.0)	16.53 (420.0)	18.67 (474.0)	14.67 (373.0)	16.53 (420.0)	23.31 (592.0)
F	3.50 (89.0)	3.50 (89.0)	3.50 (89.0)	3.50 (89.0)	3.50 (89.0)	3.50 (89.0)
Weight in lb (kg)	33 (15)	51 (23)	72 (33)	47 (21)	51 (23)	108 (49)

NEMA 7/9—30–100A

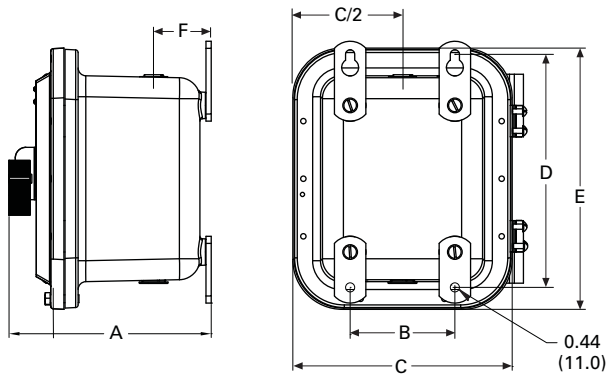

Note

① Accessories and modifications shown on Page V2-T1-15 are NOT applicable to NEMA 7/9 disconnect switches.

Quick-Connect, Single-Throw and Double-Throw Switches



Quick-Connect Switches

Product Description

240V, 600 Vac Heavy-Duty, Single-Throw and Double-Throw with Cam-Lok or Posi-Lok Receptacles, Fusible, Non-Fusible

- 30–1200A
- NEMA 1 or 3R enclosures
- Provision for 200% neutral
- Non-magnetic metal mounting plate
- Crouse-Hinds “J” Power Series E1015, E1016, E1017 cam connectors
- Crouse-Hinds E200, E400 Posi-Lok panels
- Connector plugs are typically not provided, but may be special ordered
- Matching plug and cord sets are available from Eaton

Features

Eaton’s individual cable connector receptacle switches provide a convenient and safe way to quickly connect and disconnect portable equipment. The load side terminals are factory wired to individual receptacles located behind an interlocked door for added safety. The switch cannot be turned to the ON position without first closing the receptacle compartment door.

Contents

Description

Description	Page
Product Overview	V2-T1-2
General Duty	V2-T1-25
Heavy-Duty	V2-T1-30
Heavy-Duty Double Door Safety Switch	V2-T1-39
Six-Pole Switches	V2-T1-43
Double-Throw Switches	V2-T1-46
EnviroLine Stainless Steel Switch	V2-T1-53
Window Switches	V2-T1-57
Receptacle Switches	V2-T1-60
Non-Metallic KRYDON Switch	V2-T1-62
Shunt Trip Safety Switch	V2-T1-65
NEMA 7/9—Hazardous Location Disconnect Switch	V2-T1-68
Quick-Connect Switches	
Catalog Number Selection	V2-T1-71
Product Selection	V2-T1-73
Dimensions	V2-T1-74
Mill-Duty Rated, Heavy-Duty Safety Switch	V2-T1-77
Heavy-Duty Fusible Safety Switches Accepting CUBEFuses	V2-T1-79
Elevator Control Switch	V2-T1-82
Auxiliary Power Heavy-Duty Safety Switch	V2-T1-85
Left-Handed Safety Switch	V2-T1-89
Heavy-Duty Surge Switch	V2-T1-90
OEM Line Isolation (OLI) Switch	V2-T1-92
Pringle Bolted Pressure Switch	V2-T1-95
Type DS, Fusible and Non-Fusible	V2-T1-98
Type Visi-Flex DE-ION	V2-T1-101
Flange Mounted—Variable Depth	V2-T1-105
Flange Mounted—Fixed Depth	V2-T1-109

Standards and Certifications

- UL listed File No. E5239



Seismic Qualifications

- Heavy-duty switches exceed the requirements of Uniform Building Code (UBC) and California Code Title 24 OSP-0011-10, OSP-0012-10



Product Selection

For price and availability, contact the Switching Device Flex Center at 1-888-329-9272 or FlexSwitches@eaton.com.

A spring-loaded flap door in the receptacle compartment allows the cables to exit the compartment, but seals the compartment when the switch is not in use. For outdoor applications, this will reduce the possibility of insects building nests in the receptacle compartment.

- Available in double-throw and single-throw designs
- Single-throw receptacles can wire to line or load side
- Service entrance rated

An additional flap door on the main compartment allows for quick connection in the event that the appropriate plugs are not readily available.

Catalog Number Selection

Quick Connect Safety Switch

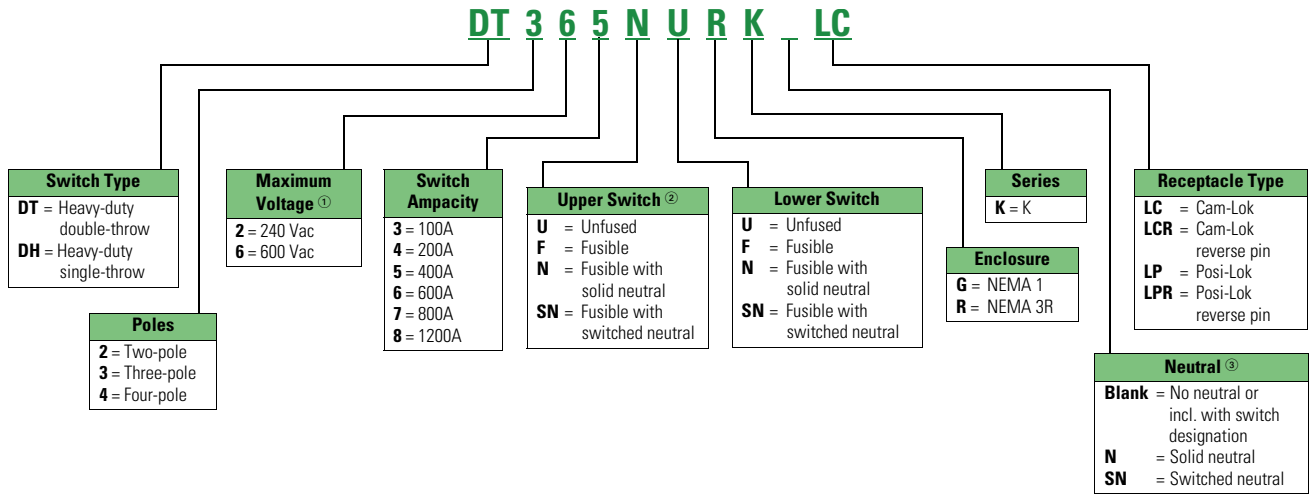

Cord Set

Example: 100 ft cord set needed for a DT364NRKLC.

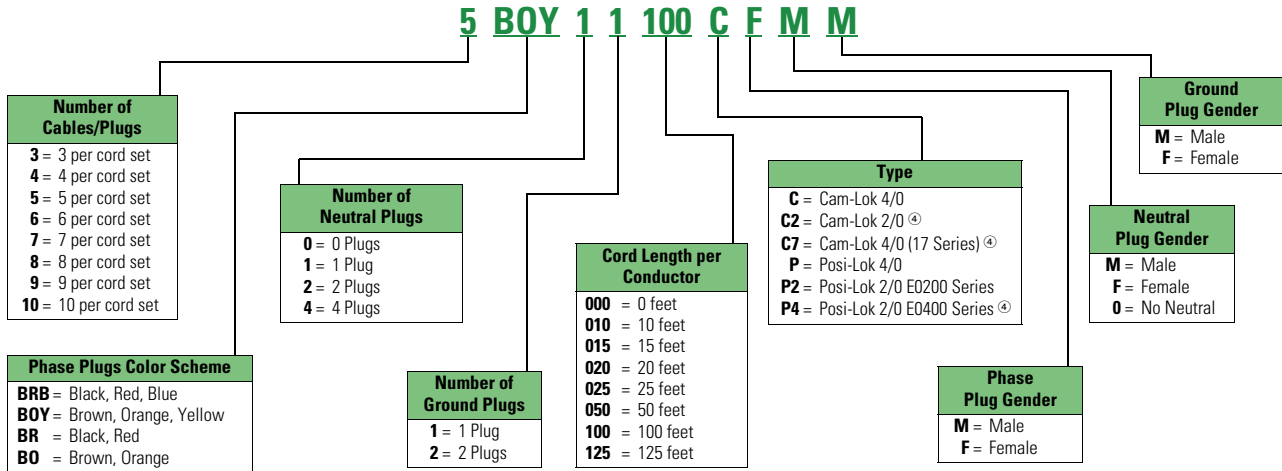

Notes

- ① Receptacle colors are voltage specific. See table on **Page V2-T1-72** for standard colors offered.
- ② When upper and lower switches are the same, the switch configuration is consolidated in one letter (e.g., "U" not "UU"). Also, a switch with a neutral will have either a solid neutral or a switched neutral, not both. Lastly, a switched neutral pole is never fused.
- ③ This field is only used when a switch is completely non-fused.
- ④ Customer special requests, not common.

We use Type W 4/0 CU flex cable.

This table is intended for use in breaking down existing catalog numbers. It is not intended for building new catalog numbers.

Standard Receptacle Color Codes provided on Switches

Matching plug and cord sets are available from Eaton.

Single-Throw Switches

Suffix	Ground				Neutral				Phase A				Phase B				Phase C			
	Gender		Color		Gender		Color		Gender		Color		Gender		Color		Gender		Color	
	Male	Female	240V	600V	Male	Female	240V	600V	Male	Female	240V	600V	Male	Female	240V	600V	Male	Female	240V	600V
LC	■	—	G	G	■	—	WH	WH	—	■	BK	BR	—	■	RD	OR	—	■	BL	YL
LCR	—	■	G	G	—	■	WH	WH	■	—	BK	BR	■	—	RD	OR	■	—	BL	YL
LP	—	■	G	G	—	■	WH	WH	—	■	BK	BR	—	■	RD	OR	—	■	BL	YL
LPR	■	—	G	G	■	—	WH	WH	■	—	BK	BR	■	—	RD	OR	■	—	BL	YL

Double-Throw Switches

Suffix	Ground				Neutral				Phase A				Phase B				Phase C			
	Gender		Color		Gender		Color		Gender		Color		Gender		Color		Gender		Color	
	Male	Female	240V	600V	Male	Female	240V	600V	Male	Female	240V	600V	Male	Female	240V	600V	Male	Female	240V	600V
LC	—	■	G	G	—	■	WH	WH	■	—	BK	BR	■	—	RD	OR	■	—	BL	YL
LCR	■	—	G	G	■	—	WH	WH	—	■	BK	BR	—	■	RD	OR	—	■	BL	YL
LP	■	—	G	G	■	—	WH	WH	■	—	BK	BR	■	—	RD	OR	■	—	BL	YL
LPR	—	■	G	G	—	■	WH	WH	—	■	BK	BR	—	■	RD	OR	—	■	BL	YL

Legend

G = Green BK = Black RD = Red BL = Blue
 WH = White BR = Brown OR = Orange YL = Yellow

Note: Chart shows typical color codes, other colors can be substituted.

Product Selection**Quick-Connect Double-Throw**

Lug Capacity and Fusing

Available Lug Capacities of the Double-Throw Switch Assembly with Cam-Lok or Posi-Lok Receptacles

Double-Throw Switch Size—Cam-Lok or Posi-Lok Receptacles	Standard Fuse	Service Terminal Openings	Load Terminal Openings	Switched Neutral Pole Load Terminal Openings	Solid Neutral Terminal Openings	Ground Terminal Openings	Receptacle Bypass Terminal
100	H	(1) 1/0–14 AWG Cu/Al	(1) 1/0–14 AWG Cu/Al	(1) 1/0–14 AWG Cu/Al	(2) 1/0–14 AWG, (1) 2–14 AWG Cu/Al	(3) 2–14 AWG Cu/Al	(1) 10–32 Screw mounting
200	H	(1) 300 kcmil–6 AWG Cu/Al	(1) 250 kcmil–6 AWG Cu/Al	(1) 250 kcmil–6 AWG Cu/Al	(2) 250 kcmil–6 AWG, (1) 1/0–14 AWG, (1) 2–14 AWG Cu/Al	(3) 2–14 AWG Cu/Al	(2) 1/4 Studs, 1.75-inch spacing
400	T	(1) 750 kcmil–1/0 or (2) 300 kcmil–1/0 Cu/Al	(1) 750 kcmil–1/0 or (2) 300 kcmil–1/0 Cu/Al	(1) 750 kcmil–1/0 or (2) 300 kcmil–1/0 Cu/Al	(6) 500 kcmil, (6) 250 kcmil–6 AWG Cu/Al	(4) 250 kcmil–6 AWG Cu/Al	(2) 1/2-13 UNC studs, 1.75-inch spacing
600	T	(4) 750 kcmil–1/0 Cu/Al	(4) 750 kcmil–1/0 Cu/Al	(4) 750 kcmil–1/0 Cu/Al	(6) 500–250 kcmil, (4) 250 kcmil–6 AWG Cu/Al	(4) 250 kcmil–6 AWG Cu/Al	(2) 1/2-13 UNC studs, 1.75-inch spacing
800	T	(4) 750 kcmil–1/0 Cu/Al	(4) 750 kcmil–1/0 Cu/Al	(4) 750 kcmil–1/0 Cu/Al	(6) 500–250 kcmil, (4) 250 kcmil–6 AWG Cu/Al	(4) 250 kcmil–6 AWG Cu/Al	(2) 1/2-13 UNC studs, 1.75-inch spacing
1200	L	(4) 750 kcmil–1/0 Cu/Al	(4) 750 kcmil–1/0 Cu/Al	(4) 750 kcmil–1/0 Cu/Al	(6) 500–250 kcmil, (4) 250 kcmil–6 AWG Cu/Al	(4) 250 kcmil–6 AWG Cu/Al	—

Quick-Connect Single-Throw Company Switch

Lug Capacity and Fusing

Company Switch Available Lug Capacities of the Single-Throw Switch Assembly with Cam-Lok or Posi-Lok Receptacles

Switch Ampacity	Standard Fuse	Line Cu/Al	Load Terminal Openings Cu/Al ①	Switched Neutral Pole Load Terminal Openings Cu/Al	Solid Neutral Terminal Openings	Ground Terminal Openings Cu/Al	Receptacle Bypass Terminal
100	H	(1) 1/0–14 AWG	(1) 1/0–14 AWG	(1) 1/0–14 AWG	(2) 14 AWG–1/0 and (2) 6–14 AWG	(1) 2–14 AWG	(1) 1/0–14 AWG
200	H	(1) 300 kcmil–6 AWG	(1) 300 kcmil–6 AWG	(1) 300 kcmil–6 AWG	(2) 6 AWG–300 kcmil and (2) 6–14 AWG	(2) 2–14 AWG	(1) 300 kcmil–6 AWG
400	H	(1) 750 kcmil–1/0 or (2) 300 kcmil–1/0	(1) 750 kcmil–1/0 or (2) 300 kcmil–1/0	(1) 750 kcmil–1/0 or (2) 300 kcmil–1/0	(2x) (2) 1/0–300 kcmil or (1) 1/0–750 kcmil and (3) 6 AWG–250 kcmil	(2) 250 kcmil–6 AWG	Crimp lug provisions
600	H	(1) 750 kcmil–1/0 and (1) 600 kcmil–2	(1) 750 kcmil–1/0 and (1) 600 kcmil–2	(1) 750 kcmil–1/0 and (1) 600 kcmil–2	(2) 2 AWG–600 kcmil and 1/0–750 kcmil and (3) 6 AWG–250 kcmil	(2) 250 kcmil–6 AWG	Crimp lug provisions
800	L	(4) 750 kcmil–1/0	(4) 750 kcmil–1/0	(4) 750 kcmil–1/0	(2x) (4) 1/0–750 kcmil and (3) 6 AWG–250 kcmil	(2) 250 kcmil–6 AWG	Crimp lug provisions
1200	L	(4) 750 kcmil–1/0	(4) 750 kcmil–1/0	(4) 750 kcmil–1/0	(2x) (4) 1/0–750 kcmil and (3) 6 AWG–250 kcmil	(2) 250 kcmil–6 AWG	—

Quick-Connect Single-Throw Generator Switch

Lug Capacity and Fusing

Generator Switch Available Lug Capacities of the Single-Throw Switch Assembly with Cam-Lok or Posi-Lok Receptacles

Switch Ampacity	Standard Fuse	Load Cu/Al	Service Terminal Openings Cu/Al ②	Switched Neutral Pole Load Terminal Openings Cu/Al	Solid Neutral Terminal Openings	Ground Terminal Openings Cu/Al	Receptacle Bypass Terminal
100	H	(1) 1/0–14 AWG	(1) 1/0–14 AWG	(1) 1/0–14 AWG	(2) 14 AWG–1/0 and (2) 6–14 AWG	(1) 2–14 AWG	(1) 1/0–14 AWG
200	H	(1) 300 kcmil–6 AWG	(1) 300 kcmil–6 AWG	(1) 300 kcmil–6 AWG	(2) 6 AWG–300 kcmil and (2) 6–14 AWG	(2) 2–14 AWG	(1) 300 kcmil–6 AWG
400	H	(1) 750 kcmil–1/0 or (2) 300 kcmil–1/0	(1) 750 kcmil–1/0 or (2) 300 kcmil–1/0	(1) 750 kcmil–1/0 or (2) 300 kcmil–1/0	(2x) (2) 1/0–300 kcmil or (1) 1/0–750 kcmil and (3) 6 AWG–250 kcmil	(2) 250 kcmil–6 AWG	(1) 750 kcmil–1/0 or (2) 300 kcmil–1/0
600	H	(4) 750 kcmil–1/0	(4) 750 kcmil–1/0	(4) 750 kcmil–1/0	2x (4) 1/0–750 kcmil and (3) 6 AWG–250 kcmil	(2) 250 kcmil–6 AWG	(4) 750 kcmil–1/0
800	L	(4) 750 kcmil–1/0	(4) 750 kcmil–1/0	(4) 750 kcmil–1/0	(2x) (4) 1/0–750 kcmil and (3) 6 AWG–250 kcmil	(2) 250 kcmil–6 AWG	(4) 750 kcmil–1/0
1200	L	(4) 750 kcmil–1/0	(4) 750 kcmil–1/0	(4) 750 kcmil–1/0	(2x) (4) 1/0–750 kcmil and (3) 6 AWG–250 kcmil	(2) 250 kcmil–6 AWG	—

Notes

① Load side terminals are factory wired to receptacles.

② Line side terminals are factory wired to receptacles.

1.1

Switching Devices

Safety Switches

1

Dimensions

Approximate Dimensions in Inches (mm)

Note: Dimensions are for estimating purposes only.

Quick Connect Double Throws, Fusible and Non-Fusible, 240V and 600V (1 of 2)

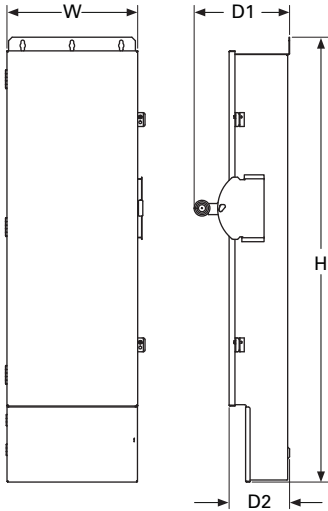

Ampere Rating	Width (W)	Height (H)	Depth (D1)	Depth (D2)	Weight lbs (kg)
100	18.57 (471.7)	62.89 (1597.4)	13.56 (344.4)	8.59 (218.2)	240 (109)
200	18.57 (471.7)	62.89 (1597.4)	13.56 (344.4)	8.59 (218.2)	240 (109)
1200	42.62 (1083.0)	87.78 (2230.0)	29.62 (752.0)	20.47 (520.0)	1025 (465)

Quick Connect Single Throws, Fusible and Non-Fusible, 240V and 600V

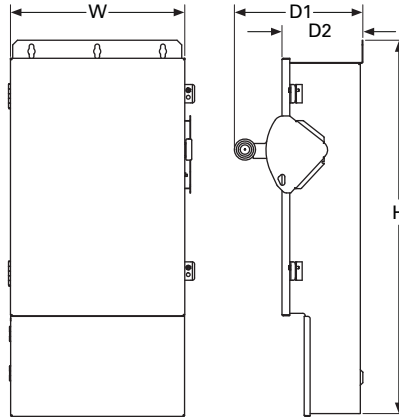

Ampere Rating	Width (W)	Height (H)	Depth (D1)	Depth (D2)	Weight lbs (kg)
100	18.57 (471.1)	39.12 (993.6)	13.68 (347.5)	8.61 (218.7)	85 (39)
200	18.57 (471.1)	41.87 (1063.5)	13.68 (347.5)	8.61 (218.7)	140 (64)
400	32.87 (834.9)	73.79 (1874.3)	16.10 (408.9)	11.14 (283.0)	370 (168)
600	32.87 (834.9)	73.79 (1874.3)	16.10 (408.9)	11.14 (283.0)	370 (168)
800	32.87 (834.9)	85.04 (2160.0)	21.73 (551.9)	16.79 (426.5)	540 (245)
1200	42.62 (1083.0)	90.23 (2292.0)	29.62 (752.0)	20.47 (520.0)	915 (415)

Quick Connect Double Throws, Fusible and Non-Fusible, 240V and 600V (2 of 2)

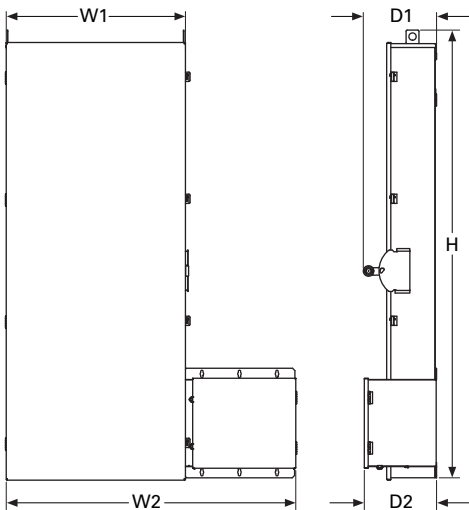

Ampere Rating	Width (W1)	Width (W2)	Height (H)	Depth (D1)	Depth (D2)	Weight lbs (kg)
400	26.68 (677.7)	50.18 (1274.6)	92.49 (2349.2)	15.61 (396.5)	15.40 (391.2)	800 (363)
600	38.18 (969.8)	61.68 (1566.7)	92.49 (2349.2)	15.61 (396.5)	15.40 (391.2)	820 (372)
800	38.18 (969.8)	61.68 (1566.7)	92.49 (2349.2)	15.61 (396.5)	15.40 (391.2)	820 (372)

Solar Disconnect Switch



Solar Disconnect Switch

Product Description

600 Vdc Heavy-Duty Fusible and Non-Fusible

- 30–600A
- Single-pole switch capable of switching 1-600 Vdc circuit

Features

- Clear line-shield covering all live parts
- For factory modifications, refer to **Pages V2-T1-15**

Standards and Certifications

- UL 98 listed, File No. E5239 and marked suitable for NEC Article 690 applications to UL 1741



Seismic Qualifications

- Heavy-duty switches exceed the requirements of Uniform Building Code (UBC) and California Code Title 24 OSP-0011-10, OSP-0012-10



Contents

Description

	<i>Page</i>
Product Overview	V2-T1-2
General Duty	V2-T1-25
Heavy-Duty	V2-T1-30
Heavy-Duty Double Door Safety Switch	V2-T1-39
Six-Pole Switches	V2-T1-43
Double-Throw Switches	V2-T1-46
EnviroLine Stainless Steel Switch	V2-T1-53
Window Switches	V2-T1-57
Receptacle Switches	V2-T1-60
Non-Metallic KRYDON Switch	V2-T1-62
Shunt Trip Safety Switch	V2-T1-65
NEMA 7/9—Hazardous Location Disconnect Switch	V2-T1-68
Quick-Connect Switches	V2-T1-70
Solar Disconnect Switch	
Standards and Certifications	V2-T1-75
Product Selection	V2-T1-76
Mill-Duty Rated, Heavy-Duty Safety Switch	V2-T1-77
Heavy-Duty Fusible Safety Switches Accepting CUBEFuses	V2-T1-79
Elevator Control Switch	V2-T1-82
Auxiliary Power Heavy-Duty Safety Switch	V2-T1-85
Left-Handed Safety Switch	V2-T1-89
Heavy-Duty Surge Switch	V2-T1-90
OEM Line Isolation (OLI) Switch	V2-T1-92
Pringle Bolted Pressure Switch	V2-T1-95
Type DS, Fusible and Non-Fusible	V2-T1-98
Type Visi-Flex DE-ION	V2-T1-101
Flange Mounted—Variable Depth	V2-T1-105
Flange Mounted—Fixed Depth	V2-T1-109

1.1

Switching Devices

Safety Switches

1

600 Vdc Heavy-Duty Fusible and Non-Fusible

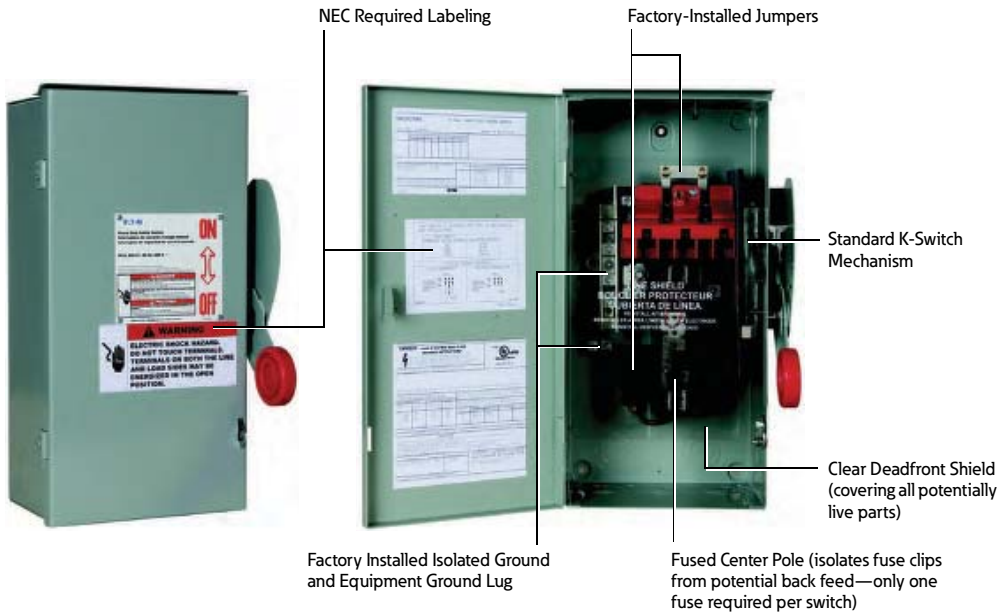

Product Selection

Solar Disconnect Switches

Ampere Rating	Fuse Class	NEMA 3R Catalog Number	NEMA 4X Catalog Number	NEMA 12 Catalog Number
30	R	DH161NRK	DH161NWK	DH161NDK
		DH161URKN	DH161UWKN	DH161UDKN
60	R	DH162NRK	DH162NWK	DH162NDK
		DH162URKN	DH162UWKN	DH162UDKN
100	R	DH163NRK	DH163NWK	DH163NDK
		DH163URKN	DH163UWKN	DH163UDKN
200	R	DH164NRK	DH164NWK	DH164NDK
		DH164URKN	DH164UWKN	DH164UDKN
400	R	DH165NRK	DH165NWK	DH165NDK
		DH165URKN	DH165UWKN	DH165UDKN
600	R	DH166NRK	DH166NWK	DH166NDK
		DH166URKN	DH166UWKN	DH166UDKN

DH361FWK-GCL



Contents

<i>Description</i>	<i>Page</i>
Product Overview	V2-T1-2
General Duty	V2-T1-25
Heavy-Duty	V2-T1-30
Heavy-Duty Double Door Safety Switch	V2-T1-39
Six-Pole Switches	V2-T1-43
Double-Throw Switches	V2-T1-46
EnviroLine Stainless Steel Switch	V2-T1-53
Window Switches	V2-T1-57
Receptacle Switches	V2-T1-60
Non-Metallic KRYDON Switch	V2-T1-62
Shunt Trip Safety Switch	V2-T1-65
NEMA 7/9—Hazardous Location Disconnect Switch	V2-T1-68
Quick-Connect Switches	V2-T1-70
Solar Disconnect Switch	V2-T1-75
Mill-Duty Rated, Heavy-Duty Safety Switch Product Selection	V2-T1-78
Heavy-Duty Fusible Safety Switches Accepting CUBEFuses	V2-T1-79
Elevator Control Switch	V2-T1-82
Auxiliary Power Heavy-Duty Safety Switch	V2-T1-85
Left-Handed Safety Switch	V2-T1-89
Heavy-Duty Surge Switch	V2-T1-90
OEM Line Isolation (OLI) Switch	V2-T1-92
Pringle Bolted Pressure Switch	V2-T1-98
Type DS, Fusible and Non-Fusible	V2-T1-101
Type Visi-Flex DE-ION	V2-T1-105
Flange Mounted—Variable Depth	V2-T1-109
Flange Mounted—Fixed Depth	V2-T1-109

Mill-Duty Rated, Heavy-Duty Safety Switch

Product Description

240V, 600 Vac Heavy-Duty, Fusible, Non-Fusible, Single-Throw

- 30–600A
- Horsepower rated
- Suitable for service entrance use
- Factory-installed copper ground lug
- Copper terminal lugs
- Fuse pullers through 200A
- For factory modifications, refer to **Page V2-T1-15**

Standards and Certifications

- UL listed File No. E5239



Seismic Qualifications

- Heavy-duty switches exceed the requirements of Uniform Building Code (UBC) and California Code Title 24 OSP-0011-10, OSP-0012-10



Product Selection

DH361FWK-GCL

Fusible



System	Ampere Rating	Fuse Class Provision	Maximum Horsepower Ratings with Time Delay Fuses						NEMA 12 Enclosure Industrial, Dust-Tight Catalog Number	NEMA 4X Enclosure Corrosion-Resistant, Stainless Steel Catalog Number
			AC		DC		Single-Phase	Three-Phase		
			Standard Fuse	Time Delay	250V	600V				
Three-Pole—240 Vac, 250 Vdc (Suitable for Service Entrance Use with a Neutral Kit Installed) ①										
	30	H	1-1/2	3	—	7-1/2	—	—	DH321FDK-GCL ②	DH321FWK-GCL
	60	H	3	7-1/2	—	15	—	—	DH322FDK-GCL ②	DH322FWK-GCL
	100	H	7-1/2	15	—	30	20	—	DH323FDK-GCL ②	③
	200	H	15	25	—	60	40	—	DH324FDK-GCL ②	DH324FWK-GCL
	400	H	—	50	—	125	50	—	DH325FDK-GCL ②	DH325FWK-GCL
	600	H	—	75	—	200	—	—	DH326FDK-GCL ②	DH326FWK-GCL
Two-Pole—480 Vac—600 Vac or DC ⑤ (Suitable for Service Entrance Use with a Neutral Kit Installed) ①										
	30	H	7-1/2	10	—	—	—	15	DH261FDK-GCL ②	DH261FWK-GCL
	60	H	20	25	—	—	—	25	DH262FDK-GCL ②	③ or ④
	100	H	30	40	—	—	—	25	DH263FDK-GCL ②	③ or ④
	200	H	50	50	—	—	—	50	DH264FDK-GCL ②	DH264FWK-GCL
Three-Pole—480 Vac—600 Vac, 250 Vdc (Suitable for Service Entrance Use with a Neutral Kit Installed) ①										
	30	H	7-1/2	10	15	20	—	—	DH361FDK-GCL ②	DH361FWK-GCL
	60	H	20	25	30	50	—	—	DH362FDK-GCL ②	DH362FWK-GCL
	100	H	30	40	60	75	—	—	DH363FDK-GCL ②	DH363FWK-GCL
	200	H	50	50	125	150	—	—	DH364FDK-GCL ②	DH364FWK-GCL
	400	H	—	—	250	350	—	—	DH365FDK-GCL ②	DH365FWK-GCL
	600	H	—	—	400	500	—	—	DH366FDK-GCL ②	DH366FWK-GCL

Non-Fusible 277/480–600V

System	Ampere Rating	Fuse Class Provision	Maximum Horsepower Ratings						NEMA 12 Enclosure Industrial, Dust-Tight Catalog Number	NEMA 4X Enclosure Corrosion-Resistant, Stainless Steel Catalog Number
			AC		DC		Single-Phase	Three-Phase		
			Standard Fuse	Time Delay	250V	600V				
Three-Pole—480 Vac—600 Vac, 250 Vdc ⑥ (Suitable for Service Entrance use with a Neutral Kit Installed) ①										
	30	—	7-1/2	10	20	30	5	—	DH361UDK-GCL ②	DH361UWK-GCL
	60	—	20	25	50	60	10	—	DH362UDK-GCL ②	DH362UWK-GCL
	100	—	40	50	75	100	20	—	DH363UDK-GCL ②	DH363UWK-GCL
	200	—	50	50	125	150	40	—	DH364UDK-GCL ②	DH364UWK-GCL
	400	—	—	—	250	350	50	—	DH365UDK-GCL ②	DH365UWK-GCL
	600	—	—	—	400	500	—	—	DH366UDK-GCL ②	DH366UWK-GCL

Notes

- ① Contact the Safety Switch Flex Center (1-888-329-9272 or FlexSwitches@eaton.com) for copper neutrals.
- ② NEMA 12 enclosures (30–600A) can be field modified to meet NEMA 3R rainproof requirements when a factory provided drain hole is opened.
- ③ Contact the Safety Switch Flex Center (1-888-329-9272 or FlexSwitches@eaton.com) for availability of this product.
- ④ Use three-pole catalog numbers below for 600 Vac, 250 Vdc maximum applications. For 600 Vdc, see note ③.
- ⑤ DC rating for 400–600A switches is 250V.
- ⑥ For two-pole applications, use outside poles of three-pole switch.

DH361FRKCB



Contents

<i>Description</i>	<i>Page</i>
Product Overview	V2-T1-2
General Duty	V2-T1-25
Heavy-Duty	V2-T1-30
Heavy-Duty Double Door Safety Switch	V2-T1-39
Six-Pole Switches	V2-T1-43
Double-Throw Switches	V2-T1-46
EnviroLine Stainless Steel Switch	V2-T1-53
Window Switches	V2-T1-57
Receptacle Switches	V2-T1-60
Non-Metallic KRYDON Switch	V2-T1-62
Shunt Trip Safety Switch	V2-T1-65
NEMA 7/9—Hazardous Location Disconnect Switch	V2-T1-68
Quick-Connect Switches	V2-T1-70
Solar Disconnect Switch	V2-T1-75
Mill-Duty Rated, Heavy-Duty Safety Switch	V2-T1-77
Heavy-Duty Fusible Safety Switches Accepting CUBEFuses	
Product Selection	V2-T1-80
Dimensions	V2-T1-81
Elevator Control Switch	V2-T1-82
Auxiliary Power Heavy-Duty Safety Switch	V2-T1-85
Left-Handed Safety Switch	V2-T1-89
Heavy-Duty Surge Switch	V2-T1-90
OEM Line Isolation (OLI) Switch	V2-T1-92
Pringle Bolted Pressure Switch	V2-T1-95
Type DS, Fusible and Non-Fusible	V2-T1-98
Type Visi-Flex DE-ION	V2-T1-101
Flange Mounted—Variable Depth	V2-T1-105
Flange Mounted—Fixed Depth	V2-T1-109

Heavy-Duty Fusible Safety Switches Accepting CUBEFuses

Product Description

600 Vac Heavy-Duty, Fusible, Single-Throw

CUBEFuses installed in a safety switch provide finger-safe protection, Class J time delay electrical performance with a smaller footprint than Class J or CC fusing, and blown fuse indication.

- 30–100A
- Horsepower rated
- For factory modifications, refer to **Page V2-T1-15**

Standards and Certifications

- UL listed File No. E5239



Seismic Qualifications

- Heavy-duty switches exceed the requirements of Uniform Building Code (UBC) and California Code Title 24 OSP-0011-10, OSP-0012-10



Product Selection

DH361FRKCB



Fusible 277/480–600V

System	Ampere Rating	Fuse Class Provision	Maximum Horsepower Ratings					NEMA 1 Enclosure Indoor Catalog Number	NEMA 3R Enclosure Rainproof Catalog Number	NEMA 12 Enclosure Industrial, Dust-Tight Catalog Number	NEMA 4X Enclosure Corrosion-Resistant, Stainless Steel Catalog Number
			Single-Phase AC		Three-Phase AC		DC 250V				
			480V	600V	480V	600V					
Three-Pole—480 Vac—600 Vac, 250 Vdc (Suitable for Service Entrance Use with a Neutral Kit Installed)											
	30	Cube	7-1/2	10	15	20	—	DH361FGKCB	DH361FRKCB	DH361FDKCB ①	DH361FWKCB
	60	Cube	20	25	30	50	—	DH362FGKCB	DH362FRKCB	DH362FDKCB ①	DH362FWKCB
	100	Cube	30	40	60	75	—	DH363FGKCB	DH363FRKCB	DH363FDKCB ①	DH363FWKCB

Fusible 277/480–600V

System	Ampere Rating	Fuse Class Provision	Maximum Horsepower Ratings					NEMA 1 Enclosure Indoor Catalog Number	NEMA 3R Enclosure Rainproof Catalog Number	NEMA 12 Enclosure Industrial, Dust-Tight Catalog Number	NEMA 4X Enclosure Corrosion-Resistant, Stainless Steel Catalog Number
			Single-Phase AC		Three-Phase AC		DC 250V				
			480V	600V	480V	600V					
Four-Wire (Three Blades, Three Fuses, S/N) 480 Vac—600 Vac, 250 Vdc											
	30	Cube	7-1/2	10	15	20	—	DH361NGKCB	DH361NRKCB	DH361NDKCB ①	DH361NWKCB
	60	Cube	20	25	30	50	—	DH362NGKCB	DH362NRKCB	DH362NDKCB ①	DH362NWKCB
	100	Cube	30	40	60	75	—	DH363NGKCB	DH363NRKCB	DH363NDKCB ①	DH363NWKCB

Fusible 277/480–600V

System	Ampere Rating	Fuse Class Provision	Maximum Horsepower Ratings					NEMA 1 Enclosure Indoor Catalog Number	NEMA 3R Enclosure Rainproof Catalog Number	NEMA 12 Enclosure Industrial, Dust-Tight Catalog Number	NEMA 4X Enclosure Corrosion-Resistant, Stainless Steel Catalog Number
			Two-Phase AC		Three-Phase AC		DC 250V				
			480V	600V	480V	600V					
Four-Pole—480 Vac—600 Vac, 250 Vdc											
	30	Cube	20	25	15	20	—	DH461FGKCB ①		①②	②
	60	Cube	40	50	30	50	—	DH462FGKCB ①		①②	②
	100	Cube	50	50	60	75	—	DH463FGKCB ①		DH463FDKCB ①	②

Notes

- ① NEMA 12 enclosures (30–100A) can be field modified to meet NEMA 3R rainproof requirements when a factory provided drain hole is opened.
- ② Contact the Safety Switch Flex Center (1-888-329-9272 or FlexSwitches@eaton.com) for availability of this product.

Fusible with Window 277/480–600V

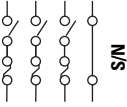
System	Ampere Rating	Fuse Class Provision	Maximum Horsepower Ratings				DC 250V/600V	NEMA 12 Enclosure Industrial, Dust-Tight Catalog Number	NEMA 4X Enclosure Corrosion-Resistant, Stainless Steel Catalog Number
			Single-Phase AC		Three-Phase AC				
			480V	600V	480V	600V			
Four-Wire (Three Blades, Three Fuses, S/N), 600 Vac—250 Vdc ①									
	30	Cube	7-1/2	10	15	20	—	DH361NDKWCB ①	DH361NWKWCB
	60	Cube	20	25	30	50	—	DH362NDKWCB ①	DH362NWKWCB
	100	Cube	30	40	60	75	—	DH363NDKWCB ①	DH363NWKWCB

Notes

① NEMA 12 enclosures (30–100A) can be field modified to meet NEMA 3R rainproof requirements when a factory provided drain hole is opened.

Fuses are supplied as separate items.

Dimensions

Approximate Dimensions in Inches (mm)

Note: Dimensions are for estimating purposes only.

Fusible Safety Switch

Ampere Rating	Width (W)	Height (H)	Depth (D)	Depth (D2)	Weight Lbs (kg)
NEMA 1, 3R					
30	8.13 (206.5)	15.88 (403.4)	10.00 (254.0)	5.25 (133.3)	20 (9.08)
60	8.13 (206.5)	15.88 (403.4)	10.00 (254.0)	5.25 (133.3)	20 (9.08)
100	11.13 (282.7)	21.69 (550.9)	10.00 (254.0)	5.25 (133.3)	27 (12.258)
NEMA 12, 4X Stainless Steel and Fusible with Window					
30	8.13 (206.5)	17.88 (454.2)	10.00 (254.0)	5.50 (139.7)	22 (9.988)
60	8.13 (206.5)	17.88 (454.2)	10.00 (254.0)	5.50 (139.7)	22 (9.988)
100	11.13 (282.7)	24.00 (609.6)	10.25 (260.4)	5.50 (139.7)	30 (13.62)

NEMA 1, 3R 30–100A

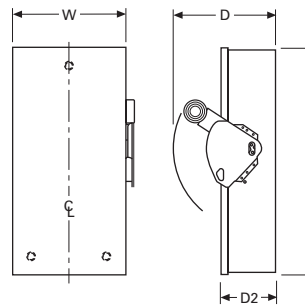

NEMA 4X, 12 and with Windows 30–100A

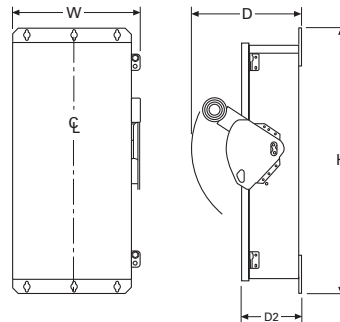

Note: A factory-installed ground lug is supplied in all heavy-duty safety switches.

Elevator Control Switch



Elevator Control Switch

Features, Benefits and Functions

Standard Features

- 30–400A, 600 Vac three-phase fused power switch
- 200,000A rms short-circuit current rating
- Shunt trip 120V
- Control power terminal block
- Ground lug per NEC
- Class J Fuse mounting only (Class J Fuses not included)
- Key to test switch 120V
- Mechanically interlocked auxiliary contact for hydraulic elevators with automatic recall (5A, 120 Vac rated) 1NO, 1NC

Optional Features

- Control power transformer with fuses and blocks
- Fire safety interface relay
- Pilot light—ON
- Isolated neutral lug (oversized 200% rated neutral option available where required by excessive nonlinear loads)
- Fire alarm voltage monitoring relay (to monitor shunt trip voltage)
- NEMA 3R, 4 and 12 enclosures available through 200A
- Phase failure and undervoltage relay available, consult factory
- For added protection, use Eaton fuse covers to improve maintenance personnel protection, through 200A (OSHA 1910.333, Paragraph C)

Contents

<i>Description</i>	<i>Page</i>
Product Overview	V2-T1-2
General Duty	V2-T1-25
Heavy-Duty	V2-T1-30
Heavy-Duty Double Door Safety Switch	V2-T1-39
Six-Pole Switches	V2-T1-43
Double-Throw Switches	V2-T1-46
EnviroLine Stainless Steel Switch	V2-T1-53
Window Switches	V2-T1-57
Receptacle Switches	V2-T1-60
Non-Metallic KRYDON Switch	V2-T1-62
Shunt Trip Safety Switch	V2-T1-65
NEMA 7/9—Hazardous Location Disconnect Switch	V2-T1-68
Quick-Connect Switches	V2-T1-70
Solar Disconnect Switch	V2-T1-75
Mill-Duty Rated, Heavy-Duty Safety Switch	V2-T1-77
Heavy-Duty Fusible Safety Switches Accepting CUBEFuses	V2-T1-79
Elevator Control Switch	
Catalog Number Selection	V2-T1-83
Technical Data and Specifications	V2-T1-83
Dimensions	V2-T1-84
Auxiliary Power Heavy-Duty Safety Switch	V2-T1-85
Left-Handed Safety Switch	V2-T1-89
Heavy-Duty Surge Switch	V2-T1-90
OEM Line Isolation (OLI) Switch	V2-T1-92
Pringle Bolted Pressure Switch	V2-T1-95
Type DS, Fusible and Non-Fusible	V2-T1-98
Type Visi-Flex DE-ION	V2-T1-101
Flange Mounted—Variable Depth	V2-T1-105
Flange Mounted—Fixed Depth	V2-T1-109

Standards and Certifications

- UL 98 Enclosed and Deadfront Switch Guide 96NK3917, File No. E182262
- NEMA 1, UL 50, listed enclosure
- cUL® per Canadian Standards C22.2, No. 0-M91-CAN/CSA® C22.2, No. 4-M89 Enclosed Switch



Seismic Qualifications

- Heavy-duty switches exceed the requirements of Uniform Building Code (UBC) and California Code Title 24 OSP-0011-10, OSP-0012-10



Catalog Number Selection

Elevator Control Switch

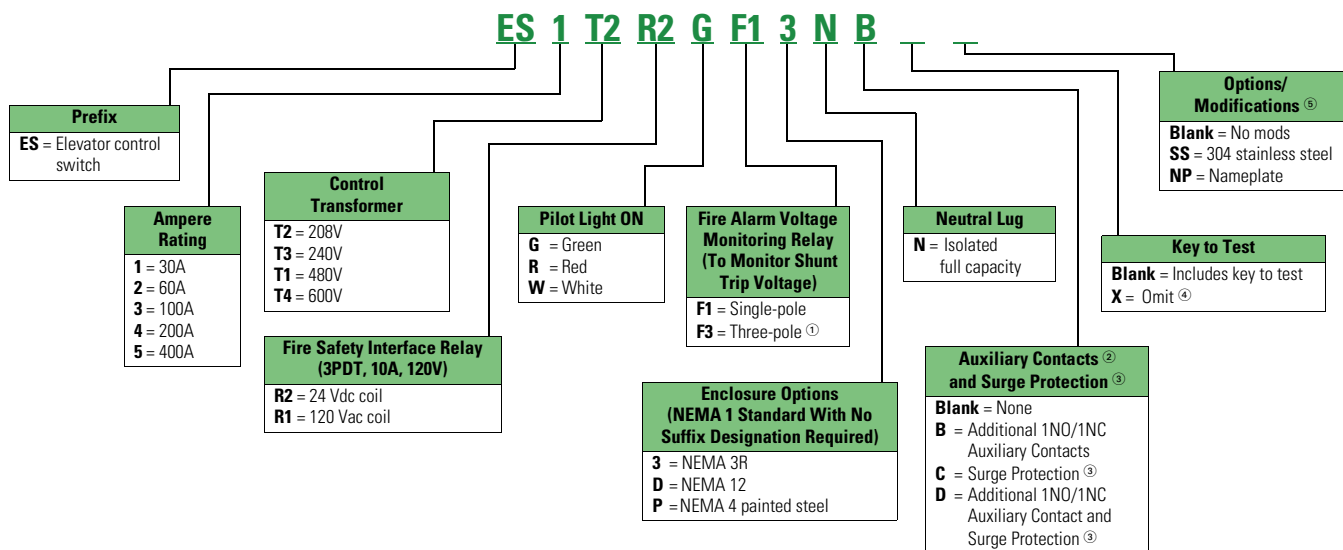

Catalog Number Example: ES3T1R1GF3

- 100A S.T. switch 480V-3P—ES3
- 480–120V CPT—T1
- 120 Vac coil fire safety interface relay—R1
- Pilot light—ON (Green)—G
- Fire alarm voltage monitoring relay (three-pole)—F3

Technical Data and Specifications

Elevator Control Switch Maximum hp Rating—Sizing Based on Motor Type

Voltage Rating (Vac Three-Phase)	Ampere Rating			Ampere Rating			Ampere Rating			Ampere Rating			Ampere Rating		
	30A, ES1			60A, ES2			100A, ES3			200A, ES4			400A, ES5		
	A	B	C	A	B	C	A	B	C	A	B	C	A	B	C
208	5	5	3	10	10	10	20	15	15	40	40	30	—	—	—
240	5	5	5	10	10	10	20	20	15	50	40	30	—	—	—
480	10	10	10	30	25	20	50	40	30	100	75	75	—	—	—
600	15	15	10	30	30	25	60	50	40	125	100	100	—	—	—

Notes

- ① F3 Option only available with R1 relay selection.
- ② All Elevator Control Switches come with 1NO/1NC auxiliary contact as standard.
- ③ For specific information on Eaton's SP1 surge protective devices, refer to Product Aid PA01005006E.
- ④ Required by some codes in Arizona.
- ⑤ Not in Bid Manager® but available through the Flex Center (FlexSwitches@Eaton.com or 1-888-329-9272).

1

Dimensions

Approximate Dimensions in Inches (mm)

Note: Dimensions are for estimating purposes only.

Elevator Control Switch Dimensions and Lug Data

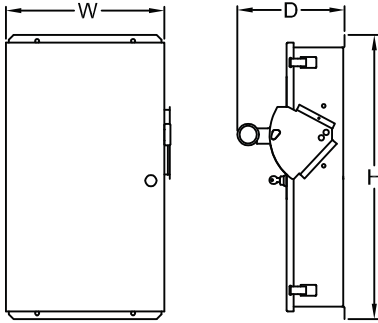

Ampere Rating	NEMA 1 ^①			NEMA 3R, 12 ^②			Catalog Number
	Height	Width	Depth	Height	Width	Depth	
30	29.62 (752.3)	16.35 (415.4)	11.18 (283.9)	29.62 (752.3)	16.35 (415.4)	11.18 (283.9)	ES1
60	29.62 (752.3)	16.35 (415.4)	11.18 (283.9)	29.62 (752.3)	16.35 (415.4)	11.18 (283.9)	ES2
100	29.62 (752.3)	16.35 (415.4)	11.18 (283.9)	29.62 (752.3)	16.35 (415.4)	11.18 (283.9)	ES3
200	32.63 (828.9)	20.38 (517.8)	11.28 (286.4)	32.63 (828.9)	20.38 (517.8)	11.28 (286.4)	ES4
400	54.63 (1387.7)	25.21 (640.3)	12.69 (322.3)	54.63 (1387.7)	25.21 (640.3)	12.69 (322.3)	ES5

Lug Data

Ampere Rating	Line Side Lug Range	Load Side Lug Range
30	#14–1/0	#14–#2
60	#14–1/0	#14–#2
100	#14–1/0	#14–1/0
200	#4–4/0	#4–300 kcmil
400	(2) #2–500 kcmil	(2) 1/0–300 kcmil or (1) 1/0–750 kcmil

Notes

^① Standard oversize enclosure to mount control power transformer fire safety interface relay and control terminal blocks.

^② Contact factory for dimensions for NEMA 4 enclosure.

DH323FRKA1240



Contents

<i>Description</i>	<i>Page</i>
Product Overview	V2-T1-2
General Duty	V2-T1-25
Heavy-Duty	V2-T1-30
Heavy-Duty Double Door Safety Switch	V2-T1-39
Six-Pole Switches	V2-T1-43
Double-Throw Switches	V2-T1-46
EnviroLine Stainless Steel Switch	V2-T1-53
Window Switches	V2-T1-57
Receptacle Switches	V2-T1-60
Non-Metallic KRYDON Switch	V2-T1-62
Shunt Trip Safety Switch	V2-T1-65
NEMA 7/9—Hazardous Location Disconnect Switch	V2-T1-68
Quick-Connect Switches	V2-T1-70
Solar Disconnect Switch	V2-T1-75
Mill-Duty Rated, Heavy-Duty Safety Switch	V2-T1-77
Heavy-Duty Fusible Safety Switches Accepting CUBEFuses	V2-T1-79
Elevator Control Switch	V2-T1-82
Auxiliary Power Heavy-Duty Safety Switch Catalog Number Selection	V2-T1-86
Product Selection	V2-T1-86
Dimensions	V2-T1-88
Left-Handed Safety Switch	V2-T1-89
Heavy-Duty Surge Switch	V2-T1-90
OEM Line Isolation (OLI) Switch	V2-T1-92
Pringle Bolted Pressure Switch	V2-T1-98
Type DS, Fusible and Non-Fusible	V2-T1-101
Type Visi-Flex DE-ION	V2-T1-105
Flange Mounted—Variable Depth	V2-T1-109
Flange Mounted—Fixed Depth	V2-T1-109

Auxiliary Power Heavy-Duty Safety Switch

Product Description

NEC Article 210.63 requires that a 125V, single-phase, 15 or 20A rated receptacle outlet be installed at an accessible location for the servicing of heating, air-conditioning and refrigeration equipment. The receptacle must be located on the same level and within 25 ft (7.5m) of the heating, air-conditioning and refrigeration equipment. Eaton's heavy-duty safety switch is an ideal solution for these applications, including elimination of the need for running a separate 120V circuit to the rooftop.

Features

- 30–200A
- Horsepower rated
- NEMA 3R outdoor enclosure standard
- 15A ground fault receptacle standard

Standards and Certifications

- UL listed File No. E5239



Seismic Qualifications

- Heavy-duty switches exceed the requirements of Uniform Building Code (UBC) and California Code Title 24 OSP-0011-10, OSP-0012-10



Catalog Number Selection

Auxiliary Power Heavy-Duty Safety Switch

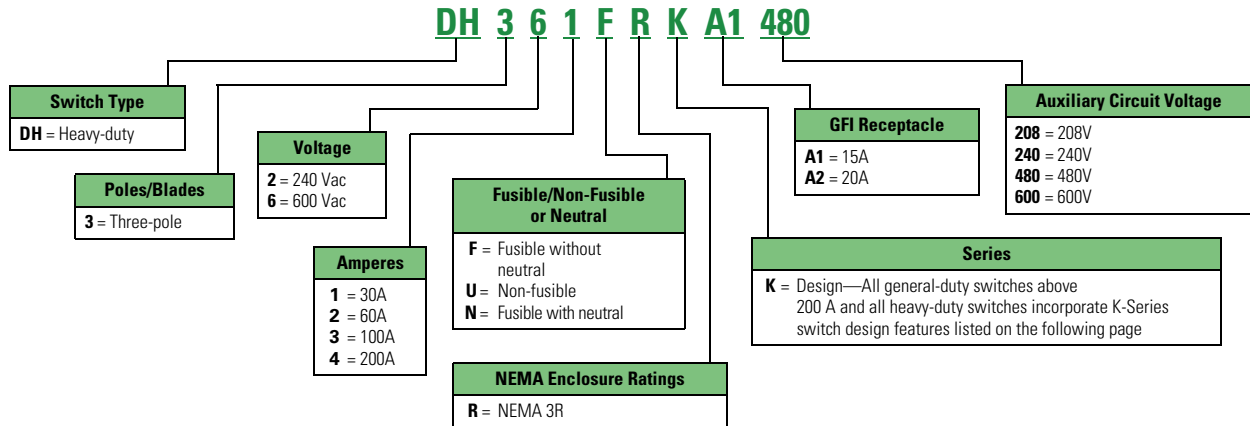

Product Selection

Non-Fusible 240 Vac–600 Vac—Three-Pole

Ampere Rating	Maximum Horsepower Ratings			Three-Phase AC			15A GFI Receptacle Catalog Number	20A GFI Receptacle Catalog Number
	Single-Phase AC 240V	480V	600V	240V	480V	600V		
208 Vac Auxiliary Circuit Voltage								
30	—	—	—	—	—	—	DH321URKA1208	DH321URKA2208
60	—	—	—	—	—	—	DH322URKA1208	DH322URKA2208
100	—	—	—	—	—	—	DH323URKA1208	DH323URKA2208
200	—	—	—	—	—	—	DH324URKA1208	DH324URKA2208
240 Vac Auxiliary Circuit Voltage								
30	3	—	—	10	—	—	DH321URKA1240	DH321URKA2240
60	10	—	—	20	—	—	DH322URKA1240	DH322URKA2240
100	20	—	—	40	—	—	DH323URKA1240	DH323URKA2240
200	15	—	—	60	—	—	DH324URKA1240	DH324URKA2240
480 Vac Auxiliary Circuit Voltage								
30	3	7-1/2	10	10	20	30	DH361URKA1480	DH361URKA2480
60	10	20	25	20	50	60	DH362URKA1480	DH362URKA2480
100	20	40	50	40	75	100	DH363URKA1480	DH363URKA2480
200	15	50	50	60	125	150	DH364URKA1480	DH364URKA2480
600 Vac Auxiliary Circuit Voltage								
30	3	7-1/2	10	10	20	30	DH361URKA1600	DH361URKA2600
60	10	20	25	20	50	60	DH362URKA1600	DH362URKA2600
100	20	40	50	40	75	100	DH363URKA1600	DH363URKA2600
200	15	50	50	60	125	150	DH364URKA1600	DH364URKA2600

Note

Contact the Safety Switch Flex Center (1-888-329-9272 or FlexSwitches@eaton.com) for additional options, including 20A GFI receptacles.

DH323FRKA1240



Fusible 240 Vac—Three-Pole

Ampere Rating	Fuse Type Provision	Maximum Horsepower Ratings (AC)				15A GFI Receptacle Catalog Number	20A GFI Receptacle Catalog Number
		Standard Fuse Single-Phase	Three-Phase	Time Delay Single-Phase	Three-Phase		
208 Vac Auxiliary Circuit Voltage							
30	H	—	—	—	—	DH321FRKA1208	DH321FRKA2208
60	H	—	—	—	—	DH322FRKA1208	DH322FRKA2208
100	H	—	—	—	—	DH323FRKA1208	DH323FRKA2208
200	H	—	—	—	—	DH324FRKA1208	DH324FRKA2208
240 Vac Auxiliary Circuit Voltage							
30	H	1-1/2	3	—	7-1/2	DH321FRKA1240	DH321FRKA2240
60	H	3	7-1/2	—	15	DH322FRKA1240	DH322FRKA2240
100	H	7-1/2	15	—	30	DH323FRKA1240	DH323FRKA2240
200	H	15	25	—	60	DH324FRKA1240	DH324FRKA2240

Fusible 600 Vac—Three-Pole

Ampere Rating	Fuse Type Provision	Maximum Horsepower Ratings with Time Delay Fuses				15A GFI Receptacle Catalog Number	20A GFI Receptacle Catalog Number
		Single-Phase AC		Three-Phase AC			
		480V	600V	480V	600V		
480 Vac Auxiliary Circuit Voltage							
30	H	7-1/2	10	15	20	DH361FRKA1480	DH361FRKA2480
60	H	20	25	30	50	DH362FRKA1480	DH362FRKA2480
100	H	30	40	60	75	DH363FRKA1480	DH363FRKA2480
200	H	50	50	125	150	DH364FRKA1480	DH364FRKA2480
600 Vac Auxiliary Circuit Voltage							
30	H	7-1/2	10	15	20	DH361FRKA1600	DH361FRKA2600
60	H	20	25	30	50	DH362FRKA1600	DH362FRKA2600
100	H	30	40	60	75	DH363FRKA1600	DH363FRKA2600
200	H	50	50	125	150	DH364FRKA1600	DH364FRKA2600

Fusible 240 Vac—Three-Pole

Ampere Rating	Fuse Type Provision	Maximum Horsepower Ratings AC				15A GFI Receptacle Catalog Number	20A GFI Receptacle Catalog Number
		Standard Fuse Single-Phase	Three-Phase	Time Delay Single-Phase	Three-Phase		
208 Vac Auxiliary Circuit Voltage							
30	H	—	—	—	—	DH321NRKA1208	DH321NRKA2208
60	H	—	—	—	—	DH322NRKA1208	DH322NRKA2208
100	H	—	—	—	—	DH323NRKA1208	DH323NRKA2208
200	H	—	—	—	—	DH324NRKA1208	DH324NRKA2208
240 Vac Auxiliary Circuit Voltage							
30	H	1-1/2	3	—	7-1/2	DH321NRKA1240	DH321NRKA2240
60	H	3	7-1/2	—	15	DH322NRKA1240	DH322NRKA2240
100	H	7-1/2	15	—	30	DH323NRKA1240	DH323NRKA2240
200	H	15	25	—	60	DH324NRKA1240	DH324NRKA2240

Fusible 600 Vac—Three-Pole

Ampere Rating	Fuse Type Provision	Maximum Horsepower Ratings with Time Delay Fuses				15A GFI Receptacle Catalog Number	20A GFI Receptacle Catalog Number
		Single-Phase AC		Three-Phase AC			
		480V	600V	480V	600V		
480 Vac Auxiliary Circuit Voltage							
30	H	7-1/2	10	15	20	DH361NRKA1480	DH361NRKA2480
60	H	20	25	30	50	DH362NRKA1480	DH362NRKA2480
100	H	30	40	60	75	DH363NRKA1480	DH363NRKA2480
200	H	50	50	125	150	DH364NRKA1480	DH364NRKA2480
600 Vac Auxiliary Circuit Voltage							
30	H	7-1/2	10	15	20	DH361NRKA1600	DH361NRKA2600
60	H	20	25	30	50	DH362NRKA1600	DH362NRKA2600
100	H	30	40	60	75	DH363NRKA1600	DH363NRKA2600
200	H	50	50	125	150	DH364NRKA1600	DH364NRKA2600

Note

Contact the Safety Switch Flex Center (1-888-329-9272 or FlexSwitches@eaton.com) for additional options, including 20A GFI receptacles.

Dimensions

Approximate Dimensions in Inches (mm)

Auxiliary Power Heavy-Duty Safety Switch

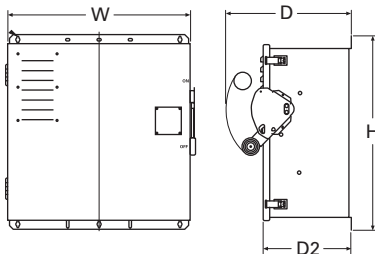

Ampere Rating	NEMA 3R Width (W)	Height (H)	Depth (D1)	Depth (D2)	Weight Lb (kg)
30	26.58 (675.1)	24.93 (633.2)	16.00 (406.4)	11.29 (286.8)	①
60	26.58 (675.1)	24.93 (633.2)	16.00 (406.4)	11.29 (286.8)	①
100	26.58 (675.1)	24.93 (633.2)	16.00 (406.4)	11.29 (286.8)	①

Note

① 108 lbs (49 kg) with a 15 A GFI receptacle; 130 lbs (59 kg) with a 20 A GFI receptacle.

Left-Handed Safety Switch



Contents

<i>Description</i>	<i>Page</i>
Product Overview	V2-T1-2
General Duty	V2-T1-25
Heavy-Duty	V2-T1-30
Heavy-Duty Double Door Safety Switch	V2-T1-39
Six-Pole Switches	V2-T1-43
Double-Throw Switches	V2-T1-46
EnviroLine Stainless Steel Switch	V2-T1-53
Window Switches	V2-T1-57
Receptacle Switches	V2-T1-60
Non-Metallic KRYDON Switch	V2-T1-62
Shunt Trip Safety Switch	V2-T1-65
NEMA 7/9—Hazardous Location Disconnect Switch	V2-T1-68
Quick-Connect Switches	V2-T1-70
Solar Disconnect Switch	V2-T1-75
Mill-Duty Rated, Heavy-Duty Safety Switch	V2-T1-77
Heavy-Duty Fusible Safety Switches Accepting CUBEFuses	V2-T1-79
Elevator Control Switch	V2-T1-82
Auxiliary Power Heavy-Duty Safety Switch	V2-T1-85
Left-Handed Safety Switch Heavy-Duty Surge Switch	V2-T1-90
OEM Line Isolation (OLI) Switch	V2-T1-92
Pringle Bolted Pressure Switch	V2-T1-95
Type DS, Fusible and Non-Fusible	V2-T1-98
Type Visi-Flex DE-ION	V2-T1-101
Flange Mounted—Variable Depth	V2-T1-105
Flange Mounted—Fixed Depth	V2-T1-109

Left-Handed Safety Switch

Product Description

Safety switches designed with the operating handle and mechanism on the left side of the switch. This option provides flexibility for installation and an added layer of safety to allow the switch to be operated without standing in front of the door.

Features

- 30–200A heavy-duty only
- Fusible and non-fusible
- NEMA 1, 3R, 12 and 4X
- Non-UL listed product
- Constructed with flange style handle (C361H1)
- No auxiliary contacts available

Note: Left-handed safety switches are supplied with a C361H1 handle.

Product Selection

Select the standard safety switch from the catalog and **add Suffix -00LH** to the catalog number.

Dimensions

Approximate Dimensions in Inches (mm)

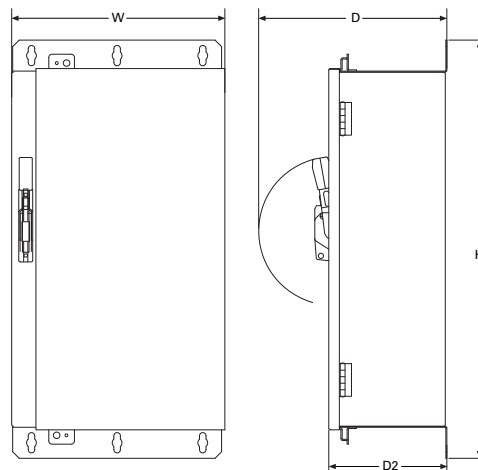

Left-Handed Safety Switch

Amperage	W	D	D2	H
30–100	12.00 (304.8)	9.05 (229.9)	9.05 (229.9)	22.30 (566.4)
	16.00 (406.4)	10.30 (261.6)	9.05 (229.9)	27.67 (702.8)

Heavy-Duty Surge Switch



Heavy-Duty Surge Switch

Product Description

Eaton's Switching Device product line combined heavy-duty safety switches and Eaton's SP1 and CVX series surge protective devices (SPDs) to provide reliable, cost-effective surge protection. Integral to the switch, an SPD provides significantly better performance compared to a device that is externally mounted, resulting in better protection for connected equipment. Eaton's new packaged solution provides contractors and end users a UL listed product by connecting the SPD to the safety switch at the factory.

Features

- 30–1200A
- NEMA 12/3R or 4X 304-grade stainless steel enclosures
- External window over switching base standard
- Window to view LEDs of SPD for quick status view
- Enhanced visible blades included
- Eaton Type SP1 and CVX surge protective devices available

Contents

<i>Description</i>	<i>Page</i>
Product Overview	V2-T1-2
General Duty	V2-T1-25
Heavy-Duty	V2-T1-30
Heavy-Duty Double Door Safety Switch	V2-T1-39
Six-Pole Switches	V2-T1-43
Double-Throw Switches	V2-T1-46
EnviroLine Stainless Steel Switch	V2-T1-53
Window Switches	V2-T1-57
Receptacle Switches	V2-T1-60
Non-Metallic KRYDON Switch	V2-T1-62
Shunt Trip Safety Switch	V2-T1-65
NEMA 7/9—Hazardous Location Disconnect Switch	V2-T1-68
Quick-Connect Switches	V2-T1-70
Solar Disconnect Switch	V2-T1-75
Mill-Duty Rated, Heavy-Duty Safety Switch	V2-T1-77
Heavy-Duty Fusible Safety Switches Accepting CUBEFuses	V2-T1-79
Elevator Control Switch	V2-T1-82
Auxiliary Power Heavy-Duty Safety Switch	V2-T1-85
Left-Handed Safety Switch	V2-T1-89
Heavy-Duty Surge Switch	
Catalog Number Selection	V2-T1-91
Dimensions	V2-T1-91
OEM Line Isolation (OLI) Switch	V2-T1-92
Pringle Bolted Pressure Switch	V2-T1-95
Type DS, Fusible and Non-Fusible	V2-T1-98
Type Visi-Flex DE-ION	V2-T1-101
Flange Mounted—Variable Depth	V2-T1-105
Flange Mounted—Fixed Depth	V2-T1-109

Standards and Certifications

- UL 98, file no. E5239
- UL 1449 4th Edition, file no. E316410



Seismic Qualifications

- Heavy-duty switches exceed the requirements of Uniform Building Code (UBC) and California Code Title 24 OSP-0011-10, OSP-0012-10



For specific information on Eaton's SP1 and CVX surge protective devices, refer to product aids PA01005006E and PA01005002E.

Catalog Number Selection

Heavy-Duty Surge Switch

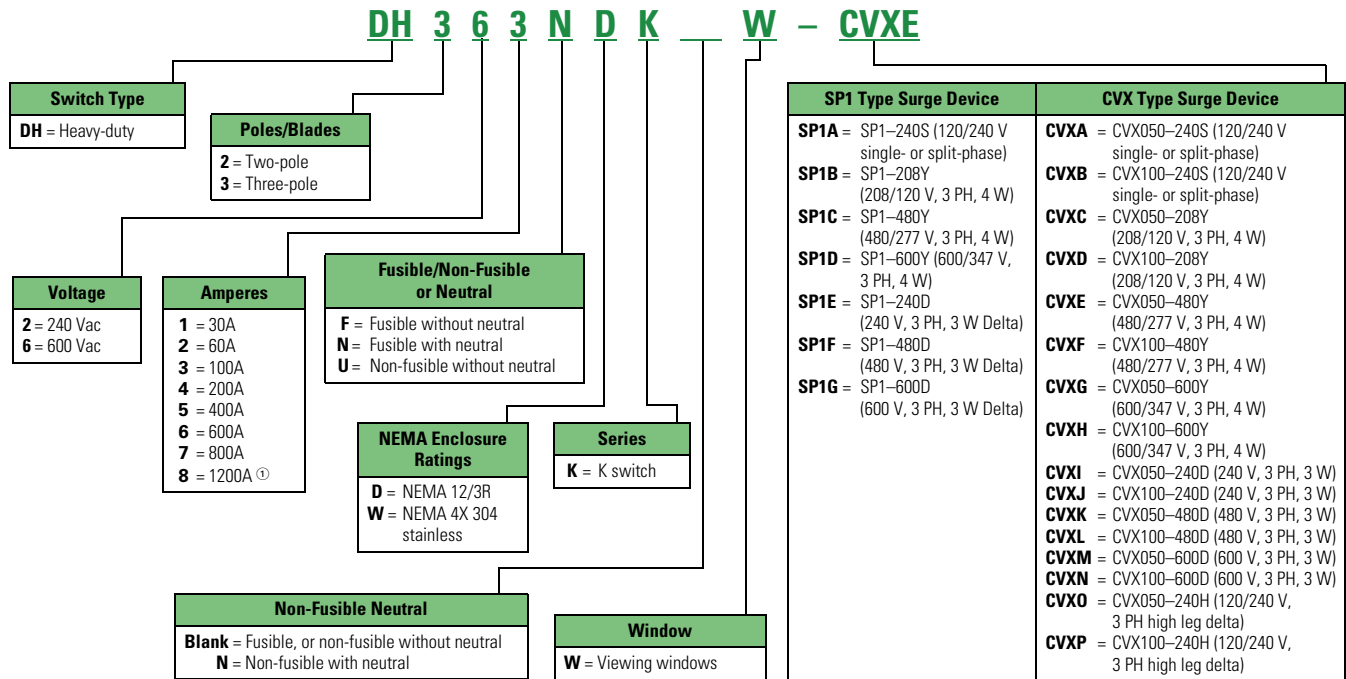

This table is intended for use in breaking down existing catalog numbers. It is not intended for building new catalog numbers.

Dimensions

Approximate Dimensions in Inches (mm)

Heavy-Duty Surge Switch

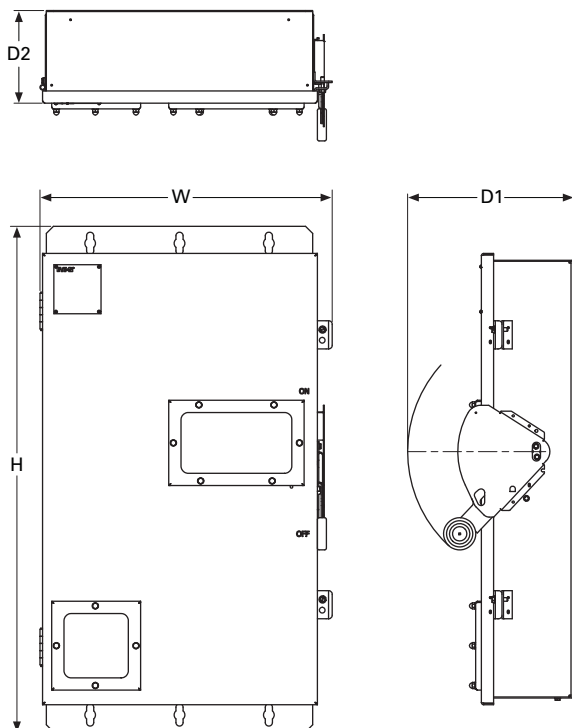

Heavy-Duty Surge Switch

Ampere Rating	Height (H)	Width (W)	Depth (D1)	Depth (D2)
30	25.02 (635.5)	15.00 (381.0)	10.31 (261.9)	5.62 (142.7)
60	25.02 (635.5)	15.00 (381.0)	10.31 (261.9)	5.62 (142.7)
100	25.02 (635.5)	15.00 (381.0)	10.31 (261.9)	5.62 (142.7)
200	35.37 (898.4)	20.44 (519.2)	11.66 (296.2)	6.48 (164.6)
400	57.47 (1459.7)	23.30 (591.8)	12.45 (316.2)	7.36 (186.9)
600	62.97 (1599.4)	24.30 (617.2)	14.08 (357.6)	8.98 (228.1)
800	71.72 (1821.7)	25.55 (649.0)	14.08 (357.6)	8.98 (228.1)
1200	73.77 (1873.8)	43.12 (1095.0)	19.20 (487.7)	12.46 (316.5)

Standard Lug Capacities

Ampere Rating	Minimum Wire Size	Maximum Wire Size	Wire Type
30	#14	#2	Cu/Al
60	#14	#2	Cu/Al
100	#14	#1/0	Cu/Al
200	#6	#300 kcmil	Cu/Al
400	(2) #1/0 (1) #1/0	(2) 300 kcmil (1) 750 kcmil	Cu/Al or Cu/Al
600	(1) #2 (1) #1/0	(1) 600 kcmil (1) 750 kcmil	Cu/Al and Cu/Al
800	(4) #1/0	(4) 750 kcmil	Cu/Al
1200	(4) #1/0	(4) 750 kcmil	Cu/Al

Note

① Available with SP1 type surge device only.

OEM Line Isolation (OLI) Switch**OEM Line Isolation (OLI) Switch****Product Description**

Traditional control panels may expose operators to line side system voltage (i.e., 480 Vac) even when the internal main disconnect is in the OFF position. Many panel-building OEMs and OEM customers are concerned with arc flash hazards and arc flash categories and may be looking for ways to reduce them.

The solution is the OEM Line Isolation (OLI) switch—another product in Eaton’s expanding offering of safer switching devices. The OLI switch provides an external disconnecting means for industrial control panels. It allows an operator to access the control panel without exposure to the line side voltage, thus enhancing safety and allowing for reduced PPE, which improves worker dexterity and mobility.

The OLI switch is designed to universally integrate to major manufacturers’ “disconnect enclosures” that will work with the Eaton C371-style handle and operating mechanism. The Eaton solution is a complete package, including enclosure, disconnect, handle, flex-cable operator and all other necessary components.

Contents

<i>Description</i>	<i>Page</i>
Product Overview	V2-T1-2
General Duty	V2-T1-25
Heavy-Duty	V2-T1-30
Heavy-Duty Double Door Safety Switch	V2-T1-39
Six-Pole Switches	V2-T1-43
Double-Throw Switches	V2-T1-46
EnviroLine Stainless Steel Switch	V2-T1-53
Window Switches	V2-T1-57
Receptacle Switches	V2-T1-60
Non-Metallic KRYDON Switch	V2-T1-62
Shunt Trip Safety Switch	V2-T1-65
NEMA 7/9—Hazardous Location Disconnect Switch	V2-T1-68
Quick-Connect Switches	V2-T1-70
Solar Disconnect Switch	V2-T1-75
Mill-Duty Rated, Heavy-Duty Safety Switch	V2-T1-77
Heavy-Duty Fusible Safety Switches Accepting CUBEFuses	V2-T1-79
Elevator Control Switch	V2-T1-82
Auxiliary Power Heavy-Duty Safety Switch	V2-T1-85
Left-Handed Safety Switch	V2-T1-89
Heavy-Duty Surge Switch	V2-T1-90
OEM Line Isolation (OLI) Switch	
Additional Features and Benefits	V2-T1-93
Catalog Number Selection	V2-T1-93
Modifications	V2-T1-93
Dimensions	V2-T1-94
Pringle Bolted Pressure Switch	V2-T1-95
Type DS, Fusible and Non-Fusible	V2-T1-98
Type Visi-Flex DE-ION	V2-T1-101
Flange Mounted—Variable Depth	V2-T1-105
Flange Mounted—Fixed Depth	V2-T1-109

Features

- 60–400A
- NEMA 12/3R and NEMA 4X 304 stainless steel enclosures
- Oversized line shield (internal to switch)
- Optional voltage portal(s)
- Gasketed side wall mounts to OEM cabinet
- Voltage indicators for line, load or line and load of switch (optional)
- Mechanical interlock—cannot open switch or OEM cabinet when handle is in the ON position
- Flange handle (for mounting on OEM cabinet)
- Custom Flex Shaft™ operator modified to work with safety switch

Standards and Certifications

- UL/cUL
- UL 98 standard, file no. E222859
- UL 50 standard, file no. E478865



Additional Features and Benefits

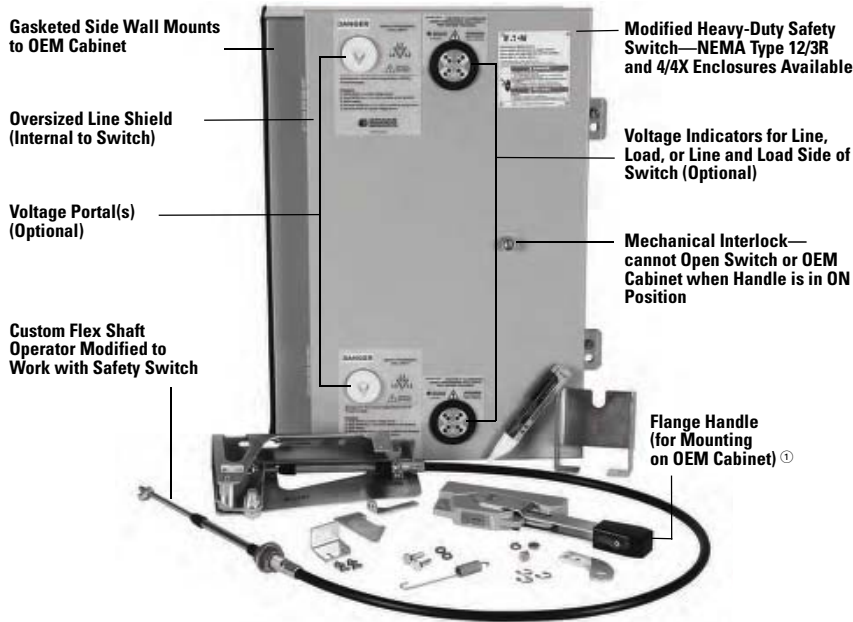

① Flex shaft operator and handle assembly is included and shipped with switch loose, for field installation.

Catalog Number Selection

OEM Line Isolation (OLI) Switch

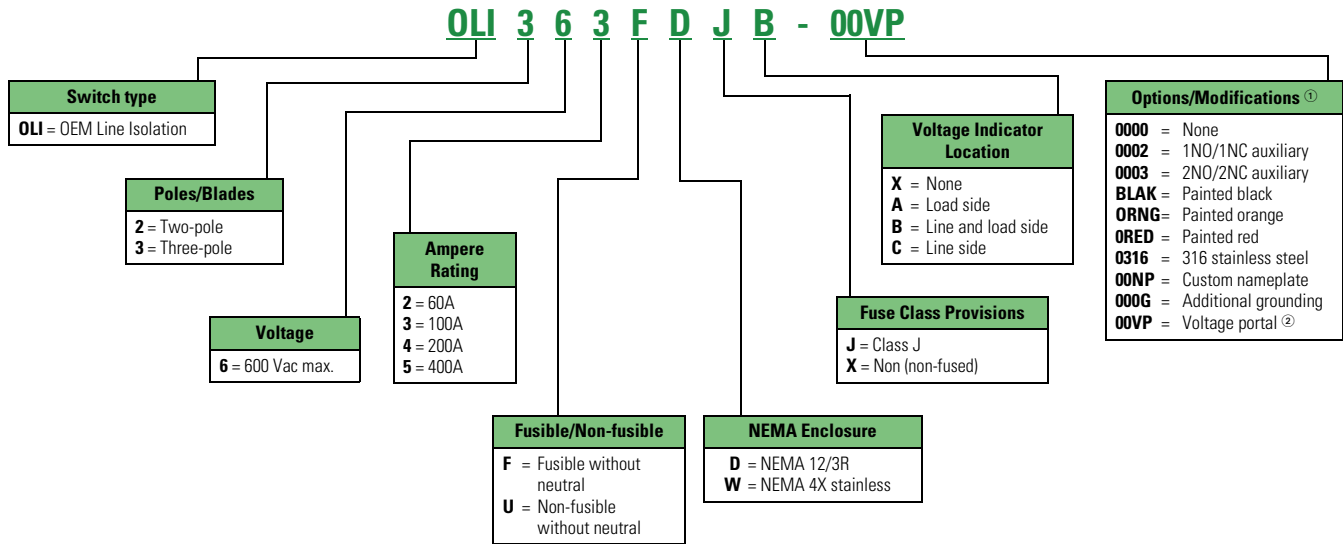

Modifications

Additions are available such as custom paint, 316-stainless enclosures, custom OEM labeling and more.

Call the Flex Center at 1-888-329-9272 for more information.

Notes

- ① More combinations and options are available.
- ② One voltage portal for each voltage indicator specified.

1

Dimensions

Approximate Dimensions in Inches (mm)

OEM Line Isolation (OLI) Switch

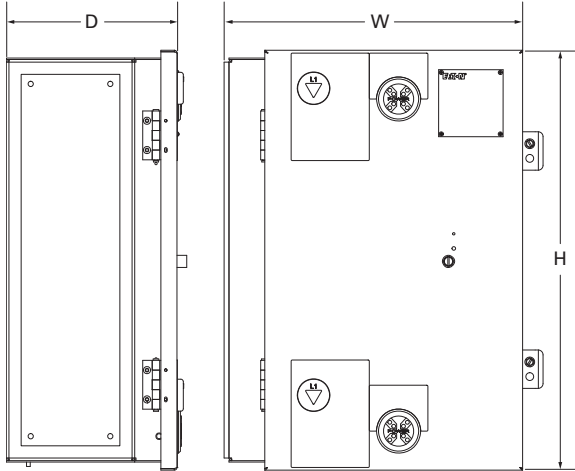

Switch Amperage	Height (H)	Width (W)	Depth (D)
60	21.49 (545.8)	16.08 (408.4)	9.24 (234.7)
100	21.49 (545.8)	16.08 (408.4)	9.24 (234.7)
200	28.21 (716.5)	18.30 (464.8)	9.24 (234.7)
400	50.15 (1273.8)	21.30 (541.0)	9.24 (234.7)

Ratings and Capacities

Ampere Rating	Short-Circuit Ratings (Amperes)		Standard Lug Capacities			Ground		
	Fusible (Class J)	Non-Fusible	Per Phase	Wire Type	Min. Wire Size	Max. Wire Size	Wire Type	
60	200 k at 600 V	10 k at 600 V	Min. Wire Size #14	Max. Wire Size #2	Wire Type Cu/Al	Min. Wire Size (2) #14	Max. Wire Size (2) 1/0	Wire Type Cu/Al
100	200 k at 600 V	10 k at 600 V	Min. Wire Size #14	Max. Wire Size 1/0	Wire Type Cu/Al	Min. Wire Size (2) #14	Max. Wire Size (2) 1/0	Wire Type Cu/Al
200	200 k at 600 V	10 k at 600 V	Min. Wire Size #6	Max. Wire Size 300 kcmil	Wire Type Cu/Al	Min. Wire Size (2) #14	Max. Wire Size (2) 1/0	Wire Type Cu/Al
400	100 k at 600 V 200 k at 480 V	10 k at 600 V	Min. Wire Size (2) 1/0 (1) 1/0	Max. Wire Size (2) 300 kcmil or (1) 750 kcmil	Wire Type Cu/Al	Min. Wire Size (2) #6	Max. Wire Size (2) 250 kcmil	Wire Type Cu/Al

Pringle Bolted Pressure Switches



CBC Type Switch



QA Type Switch

Contents

Description

	<i>Page</i>
Product Overview	V2-T1-2
General Duty	V2-T1-25
Heavy-Duty	V2-T1-30
Heavy-Duty Double Door Safety Switch	V2-T1-39
Six-Pole Switches	V2-T1-43
Double-Throw Switches	V2-T1-46
EnviroLine Stainless Steel Switch	V2-T1-53
Window Switches	V2-T1-57
Receptacle Switches	V2-T1-60
Non-Metallic KRYDON Switch	V2-T1-62
Shunt Trip Safety Switch	V2-T1-65
NEMA 7/9—Hazardous Location Disconnect Switch	V2-T1-68
Quick-Connect Switches	V2-T1-70
Solar Disconnect Switch	V2-T1-75
Mill-Duty Rated, Heavy-Duty Safety Switch	V2-T1-77
Heavy-Duty Fusible Safety Switches Accepting CUBEFuses	V2-T1-79
Elevator Control Switch	V2-T1-82
Auxiliary Power Heavy-Duty Safety Switch	V2-T1-85
Left-Handed Safety Switch	V2-T1-89
Heavy-Duty Surge Switch	V2-T1-90
OEM Line Isolation (OLI) Switch	V2-T1-92
Pringle Bolted Pressure Switch Catalog Number Selection	V2-T1-96
Product Selection	V2-T1-97
Type DS, Fusible and Non-Fusible	V2-T1-98
Type Visi-Flex DE-ION	V2-T1-101
Flange Mounted—Variable Depth	V2-T1-105
Flange Mounted—Fixed Depth	V2-T1-109

Pringle Bolted Pressure Switch

Product Description

Eaton Pringle® switches have helped pioneer development of high-quality electrical products for commercial and industrial applications since 1891. Eaton's commitment to engineering excellence and reputation for quality have made us a recolonized leader in the electrical industry, and today you'll find our electrical products in use throughout the U.S., Canada and most of the world's major markets. Eaton Pringle bolted contact switches were the first in the industry and are a worldwide standard in high-current switching applications. They are custom-built and used in many heavy-duty applications, and are suitable for use in UL 891 switchboards.

Bolted Pressure Contacts

All Pringle switches feature bolted pressure contacts. The result: blade contact surfaces are bolted closed at a pressure of 600 PSI—at both the hinge and jaw ends. The benefit: current conducting efficiency is the equivalent of a bolted bus bar connection.

Features

- 480V UL
- 600V CSA
- 800–4000 Amperes
- 5000–6000 Amperes (not UL listed)
- 200 kAIC and 100% rated with Class "L" fuses
- Top or bottom feed
- Two, three- or four-pole
- Optional blown fuse detection and protection

- Quick-positive switching action
- Manual or electrically operated mechanism
- 6X Make/12X Break contact rating
- Many options available, see following page

Spring Mechanism

All quick action switches use a unique spring mechanism for improved reliability over traditional coil springs. The unique spring design is created by a series of concave-convex washers. The paired-washer spring design provides a higher force/distance ratio, making it easier to operate the mechanism.

Should any pair of washers become inoperable for any reason, the entire spring assembly will still be operable by means of the remaining pairs. This is unlike the situation if a coil spring were to fracture or fatigue.



Sample Spring Configuration

Standards and Certifications

- 480V UL
- 600V CSA



Catalog Number Selection

Pringle Bolted Pressure Switch

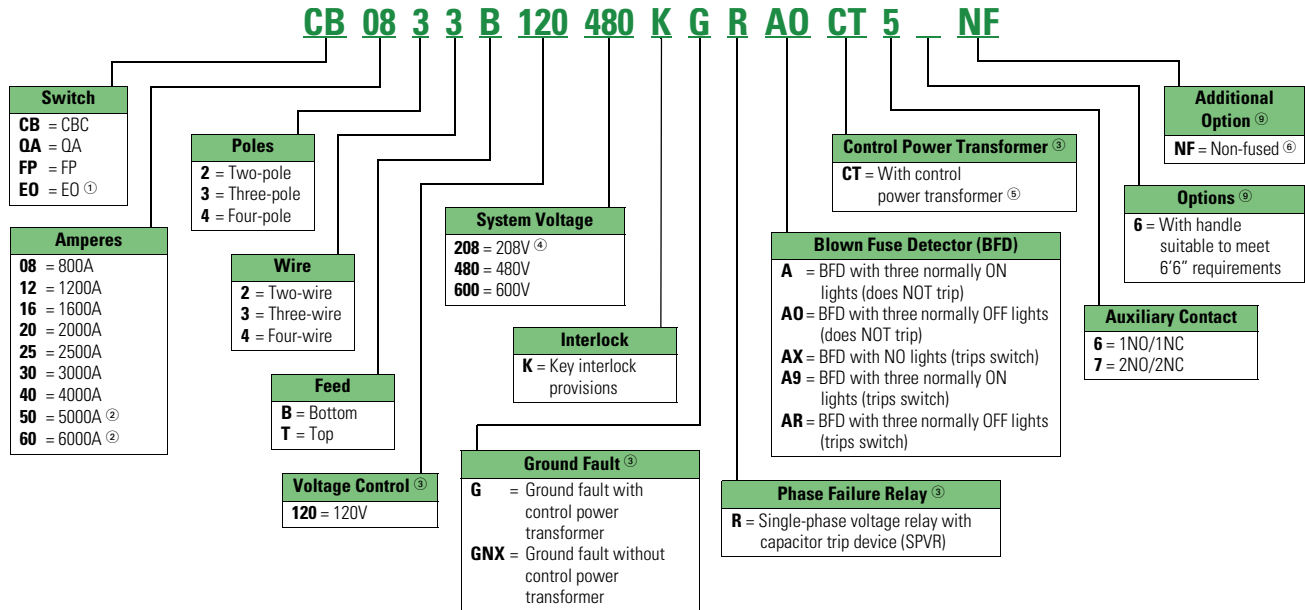

Pringle Mill Switch ②

(NEMA 1/3R/12 Enclosed)

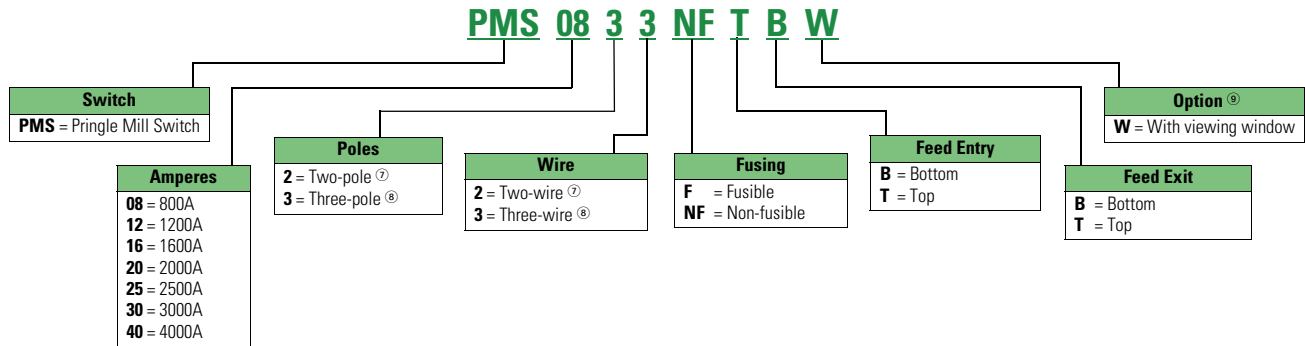

Notes

- ① Not UL listed. A separate control box may be required when adding accessories.
- ② Does not carry UL listing.
- ③ Not an option with QA type switches. GF option includes control power transformer.
- ④ For QA switches, use 480V system catalog number when referencing a 208V system.
- ⑤ Only applicable if ordering a CPT only, without ground fault.
- ⑥ Only available with QA switches and in a top-feed configuration.
- ⑦ 250 Vdc.
- ⑧ 480 Vac.
- ⑨ Additional available accessories/options—door interlock, special nameplates, custom dimensions, special paint and auxiliary contacts.

Product Selection

Manually Operated (QA)— UL Listed

Manually operated contact switch with quick positive switching action. Can be top or bottom fed.

Electrical Trip (CBC)—UL Listed

Contact switch with charge-before-close mechanism. Can be manually or electrically tripped. Optional blown fuse detector and phase failure relay with capacitor trip available.

Fault Protector Electrical Trip (FP)—UL Listed

The FP combines the features of a CBC switch but includes an integrated zero-sequence sensor and ground fault.

Pringle Mill Switch (PMS)— Not UL Listed

Manually operated contact switch with quick-positive switching action. Comes in a NEMA 1/3R/12 enclosure with a side-operated mechanism. Can be fusible or non-fusible, two- or three-pole configurations.

Service

Eaton's Pringle switches have always been manufactured with precision-made parts, and, like any mechanical device, they do require routine maintenance in order to operate at the optimal level. Over time, contact surfaces may be exposed to dirt and other contaminants, which could result in improper mechanical and/or electrical operation of the switch.

Eaton's Electrical Engineering Services & Systems team can perform planned maintenance and diagnose problems as well as respond to emergencies. Locate your local office by calling 1-800-498-2678 or visiting www.eaton.com/service and selecting the "Locate an Eaton Engineering office" link.



Aftermarket Parts

Eaton offers replacement components, as well as replacement switches. Aftermarket part information can be found in publication TD00808001E or by calling 1-877-ETN-CARE (1-877-386-2273).

Contents

<i>Description</i>	<i>Page</i>
Product Overview	V2-T1-2
General Duty	V2-T1-25
Heavy-Duty	V2-T1-30
Heavy-Duty Double Door Safety Switch	V2-T1-39
Six-Pole Switches	V2-T1-43
Double-Throw Switches	V2-T1-46
EnviroLine Stainless Steel Switch	V2-T1-53
Window Switches	V2-T1-57
Receptacle Switches	V2-T1-60
Non-Metallic KRYDON Switch	V2-T1-62
Shunt Trip Safety Switch	V2-T1-65
NEMA 7/9—Hazardous Location Disconnect Switch	V2-T1-68
Quick-Connect Switches	V2-T1-70
Solar Disconnect Switch	V2-T1-75
Mill-Duty Rated, Heavy-Duty Safety Switch	V2-T1-77
Heavy-Duty Fusible Safety Switches Accepting CUBEFuses	V2-T1-79
Elevator Control Switch	V2-T1-82
Auxiliary Power Heavy-Duty Safety Switch	V2-T1-85
Left-Handed Safety Switch	V2-T1-89
Heavy-Duty Surge Switch	V2-T1-90
OEM Line Isolation (OLI) Switch	V2-T1-92
Pringle Bolted Pressure Switch	V2-T1-95
Type DS, Fusible and Non-Fusible Product Selection	V2-T1-99
Options and Accessories	V2-T1-99
Technical Data and Specifications	V2-T1-100
Type Visi-Flex DE-ION	V2-T1-101
Flange Mounted—Variable Depth	V2-T1-105
Flange Mounted—Fixed Depth	V2-T1-109

Type DS, Fusible and Non-Fusible

Product Description

Type DS disconnect is a compact load break switch using the DE-ION arc-quenching principle and quick make/quick break over center toggle mechanism. It has visible contacts, is UL listed and is available either as a fusible or non-fusible switch.

Note: Switches through 200A are UL listed as miscellaneous switches; 400 and 600A switches are recognized under the component program of Underwriters Laboratories.

Application Description

Maximum switch-fuse application based on short-circuit current withstand (symmetrical amperes).

Short-Circuit Ratings

Switch Rating Amperes	Maximum Application at 240, 480 or 600 Vac	
	Class R Fuses	Current Limiting Fuse Class J
30	200,000	200,000
60	200,000	200,000
100	200,000	200,000
400	100,000 ①	200,000
600	100,000 ①	200,000

Standards and Certifications

- UL 98
- CSA (see table on **Page V2-T1-99**)



Reference Information

- Technical data: 29-420
- Dimensions and drilling plans: DS 29-470
- 30, 60, 100A instruction leaflet: I.L. 14857C
- 30, 60, 100A auxiliary switch instruction leaflet: I.L. 14471C
- 200A instruction leaflet: I.L. 15014A
- 200A auxiliary switch instruction leaflet: I.L. 14486A
- Handle mechanisms: TD 29-520

Note

① 480V maximum.

Product Selection**DS Type Switch****Switch Ordering Information**

Switch Rating	Fuse Clip Rating Ampere	Type Volts ^①	Catalog Number ^{②③}
30	No fuse ^④	—	DS16U
30	30	NEC 250	DS121R
30	30	NEC 600	DS161R
30	60	NEC 250	DS122
30	60	NEC 600	DS162
60	No fuse ^④	—	DS26U
60	60	NEC 250	DS222R
60	60	NEC 600	DS262R
60	100	NEC 250/600	DS263
100	No fuse ^④	—	DS36U
100	100	NEC 250/600	DS363R
100 ^⑤	200	NEC 250/600	DS364
400	No fuse ^④	—	DS56U
400	400	NEC 250/600	DS565R
600	No fuse ^④	—	DS66U
600	600	NEC 250/600	DS666R

Options and Accessories**Base Mounting Hardware**

Note: Order separately when required. No charge when ordered with switch.

Base Mounting Hardware

Description	Catalog Number
30, 60, 100A non-fusible	624B375G17
30, 60, 100A fusible	624B375G17
400 or 600A non-fusible	673B125G04
400 or 600A Fusible	673B125G05

Auxiliary Switch Kits

Note: Permits field mounting of an auxiliary switch for separate control circuit applications. Each switch includes three soldered, identified leads. Rated 250V maximum.

Auxiliary Switch Kits

Switch Used With	Contact Arrangement	Kit Catalog Number
30, 60, 100A	1A-1B	178C265G05
30, 60, 100A	2As-2Bs	178C265G06

Class R Fuse Clip Conversion Kits for Type DS Switches

Switch Rating Amperes	Volts	Kit Catalog Number
30	250	RFK121
30	600	RFK161
60	250	RFK222
60	600	RFK262
100	250/600	RFK464
400	250/600	RFK666
600	250/600	RFK666

Notes

- ① 600V ratings are suitable for Class J fuses.
- ② Switches with Catalog Number Suffix **R** are UL listed for use with Class R fuses when fuse clip conversion kits shown on this page are used.
- ③ Switches with Catalog Number Suffix **R** or **U** are CSA listed.
- ④ Rated 600V.
- ⑤ Supplied as unfused switch with separate fuse blocks.

Technical Data and Specifications

Maximum Horsepower

Type Switch	Maximum Horsepower Ratings								250 Vdc
	120 Vac		240 Vac		480 Vac		600 Vac		
	Standard	Time Delay	Standard	Time Delay	Standard	Time Delay	Standard	Time Delay	
DS16U	5	—	10	—	20	—	25	—	7-1/2
DS121R	1-1/2	3	3	7-1/2	—	—	—	—	5
DS122	3	—	7-1/2	—	—	—	—	—	5
DS161R	—	—	—	—	5	15	7-1/2	20	5
DS162	—	—	—	—	15	—	15	—	5
DS26U	10	—	20	—	40	—	60	—	15
DS222R	3	7-1/2	7-1/2	15	—	—	—	—	10
DS262R	—	—	—	—	15	30	15	50	10
DS263	—	—	15	—	25	—	30	—	10
DS36U	15	—	30	—	75	—	75	—	25
DS363R	—	—	15	30	25	60	30	75	20
DS364	—	—	25	—	50	—	60	—	20
DS56U	—	—	100	—	250	—	350	—	—
DS565R	—	—	50	100	100	250	125	350	—
DS66U	—	—	100	—	400	—	500	—	—
DS666R	—	—	75	100	150	400	200	500	—

Terminal Data

Switch Rating	Wire Range	
	Copper	Aluminum
30	#14-#2	#12-#2
60	#14-#2	#12-#2
100	#14-1/0	#12-1/0
400	(1) #4-600 kcmil or (2) 1/0-3/0	(1) #4-600 kcmil or (2) 1/0-250 kcmil
600	Same as 400A except two terminals per pole	—

Note

Terminals are suitable for either copper or aluminum cable.

Type Visi-Flex DE-ION

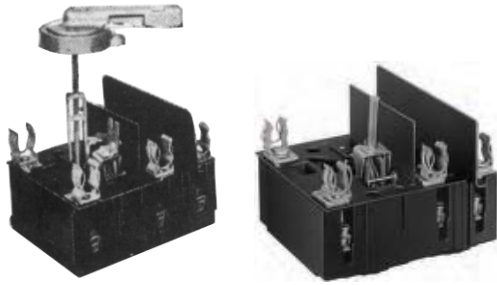

Type Visi-Flex DE-ION

Product Description

Complete Model A switch styles with fuse or non-fuse kits mounted are UL listed. Refer to “Electrical Construction Materials List,” miscellaneous switches. Switches only, no fuse, fuse clip kit and all Model T switches are recognized under the component program of Underwriters Laboratories. The external operating handle of Model A can be padlocked in the OFF position with up to three padlocks.

Terminal Data

- 30, Spec. 60A switches: #14–#4 Cu cable only
- 60, 100A switches #14–1/0 Cu cable only

Standards and Certifications

- UL 98



Contents

Description

	<i>Page</i>
Product Overview	V2-T1-2
General Duty	V2-T1-25
Heavy-Duty	V2-T1-30
Heavy-Duty Double Door Safety Switch	V2-T1-39
Six-Pole Switches	V2-T1-43
Double-Throw Switches	V2-T1-46
EnviroLine Stainless Steel Switch	V2-T1-53
Window Switches	V2-T1-57
Receptacle Switches	V2-T1-60
Non-Metallic KRYDON Switch	V2-T1-62
Shunt Trip Safety Switch	V2-T1-65
NEMA 7/9—Hazardous Location Disconnect Switch	V2-T1-68
Quick-Connect Switches	V2-T1-70
Solar Disconnect Switch	V2-T1-75
Mill-Duty Rated, Heavy-Duty Safety Switch	V2-T1-77
Heavy-Duty Fusible Safety Switches Accepting CUBEFuses	V2-T1-79
Elevator Control Switch	V2-T1-82
Auxiliary Power Heavy-Duty Safety Switch	V2-T1-85
Left-Handed Safety Switch	V2-T1-89
Heavy-Duty Surge Switch	V2-T1-90
OEM Line Isolation (OLI) Switch	V2-T1-92
Pringle Bolted Pressure Switch	V2-T1-95
Type DS, Fusible and Non-Fusible	V2-T1-98
Type Visi-Flex DE-ION	
Product Selection	V2-T1-102
Options and Accessories	V2-T1-103
Technical Data and Specifications	V2-T1-104
Flange Mounted—Variable Depth	V2-T1-105
Flange Mounted—Fixed Depth	V2-T1-109

Reference Information

- Technical data: 29-420
- Dimension sheet: 29-470
- 30, Special 60A Model A drilling instructions: I.L. 15051
- 60, 100A Model A drilling instructions: I.L. 15052A
- 30, Special 60, 100A Model A and T auxiliary switch: I.L. 12641C
- 60, 100A Model A and T fuse kit: I.S. 12565C
- No fuse kit cover mounting: I.S. 12942B
- Fuse clip kits for Class R (1226C94G01-G05): I.L. 15491
- Fuse clip kits for Class R (1226C94G06-G11): I.L. 15492
- 200 ampere instruction leaflet: I.L. 12505

Product Selection

Switch Ordering Information

Model A



Model T



Continuous Ampere Rating	Fuse or No-Fuse Kit (see photos on Page V2-T1-103)	Model A, Adjustable Depth		Model T, Toggle Operated Switch Only ^③ Catalog Number (see fuse kit at right)	Fuse Clip Kits for Model A or T NEC and Standard Time Delay ^{④⑤} (No-Fuse Kit—See Below)	
		Complete Unit Catalog Number ^①	Switch Only ^② Catalog Number (see handle and shaft below, fuse kit at right)		Clips for Class K or H Fuses Catalog Number	Clips for Class R Fuses Only Catalog Number
30	No fuse ^⑦	2607D89G01	2607D63G02	371D392G02	—	—
	30A/250V	2607D89G02	2607D63G01	371D392G01	313C590G08	1226C94G01
	60A/250V	2607D89G03	2607D63G01	371D392G01	313C590G09	1226C94G03
	100A/250V	2607D89G04	2607D63G01	371D392G01	313C590G13	1226C94G05
	30A/600V	2607D89G05	2607D63G01	371D392G01	313C590G10	1226C94G02
	60A/600V	2607D89G06	2607D63G01	371D392G01	313C590G11	1226C94G04
Special 60 ^⑥	No fuse ^⑦	2607D89G07	2607D63G06	371D392G06	—	—
	30A/250V	2607D89G08	2607D63G05	371D392G05	313C590G08	1226C94G01
	60A/250V	2607D89G09	2607D63G05	371D392G05	313C590G09	1226C94G03
	100A/250V	2607D89G10	2607D63G05	371D392G05	313C590G13	1226C94G05
	30A/600V	2607D89G11	2607D63G05	371D392G05	313C590G10	1226C94G02
	60A/600V	2607D89G12	2607D63G05	371D392G05	313C590G11	1226C94G04
60 ^⑥	No fuse ^⑦	2607D90G01	2607D66G14	657D780G12	—	—
	30A/250V	2607D90G02	2607D66G13	657D780G11	177C880G23	1226C94G06
	60A/250V	2607D90G03	2607D66G13	657D780G11	177C880G12	1226C94G08
	100A/250V	2607D90G04	2607D66G13	657D780G11	177C880G13	1226C94G10
	200A/250V	2607D90G05	2607D66G13	657D780G11	177C880G14	—
	30A/600V	2607D90G06	2607D66G13	657D780G11	177C880G24	1226C94G07
	60A/600V	2607D90G07	2607D66G13	657D780G11	177C880G15	1226C94G09
	100A/600V	2607D90G08	2607D66G13	657D780G11	177C880G16	1226C94G11
100	No fuse ^⑦	2607D91G07	2607D66G18	657D780G16	—	—
	60A/250V	2607D91G08	2607D66G17	—	177C880G12	1226C94G08
	100A/250V	2607D91G09	2607D66G17	657D780G15	177C880G13	1226C94G10
	20A/250V	2607D91G10	2607D66G17	657D780G15	177C880G14	—
	60A/600V	2607D91G11	2607D66G17	—	177C880G15	1226C94G09
	100A/600V	2607D91G12	2607D66G17	657D780G15	177C880G16	1226C94G11
	200A/600V	2607D91G13	2607D66G17	657D780G15	177C880G18	—

Notes

- ① Model A shipped as basic switch, operating handle, shaft and fuse or no-fuse kit. Model T shipped as basic switch and fuse or no-fuse kit.
- ② External operating handle, shaft and fuse or no-fuse kit required.
- ③ Fuse or no-fuse kit required.
- ④ Includes fuse clips and Micarta barriers.
- ⑤ Will also accept non-rejection type current limiting fuses:
Bussmann: 15–60A type KTN and KTS (ferrule type), 65–200A type KTN and KTS (blade type)
Chase Shawmut: 15–60A type 1 (ferrule type), 65–200A type 3 (blade type)
Federal Pacific Electric®: 15–200A types NCL and SCL
- ⑥ Special 60A switch has same dimension as 30A Visi-Flex switch. Standard 60A switch has same dimension as 100A Visi-Flex switch.
- ⑦ Rated 600V.

Special Switches and Fuse Clips**Visi-Flex Switches with Auxiliary Switch Internally Mounted**

Note: Basic switch only. Also order no-fuse kit, fuse kit, operating handle and shaft as required.

Ampere Rating	Catalog Number (for use without fuses)	Catalog Number (for use with fuses)
Model A		
30	2607D63G04	2607D63G03
Special 60	2607D63G08	2607D63G07
60	2607D66G16	2607D66G15
100	2607D66G20	2607D66G19
Model T		
30	371D392G04	371D392G03
Special 60	371D392G08	371D392G07
60	657D780G14	657D780G13
100	657D780G18	657D780G17

Options and Accessories**Fuse Kits and Shaft**

Description	Catalog Number
No fuse kits (for Models A or T)	
30, special 60A switches	313C590G14
60, 100A switches	313C363G11
Model A external operating handle	504C323G07
Model A Standard Shaft	
30, special 60A switches	2607D64G01 ^①
60, 100A switches	2607D65G01 ^②

Auxiliary Switch Kits for Model A and T Switches

Note: Permits field mounting of an auxiliary switch for separate control circuit applications. Provides an SPDT switch with 1A and/or 1B contacts. Includes three identified 18-inch soldered leads.

For Use With	Complete Kit Catalog Number
30 and special 60A switch	315C293G01 ^③
60 and 100A switch	315C293G01 ^③

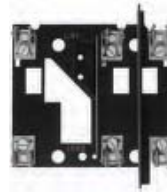
Special Fuse Kits**Fuse Clip Kit****No Fuse Kit****Current Limiting, Class J**

Note: For Model A and/or T switches. Order in place of standard fuse clips.

Switch Type, Rating	Fuse Kit Rating	Catalog Number
Model A		
30	30A/600V	503C690G01
Special 60	60A/600V	503C690G02
	100A/600V	503C690G03
60	30A/600V	503C690G15
100	60A/600V	503C690G16
	100A/600V	503C690G17
	200A/600V	503C690G18
Model T		
30	30A/600V	503C690G04
Special 60	60A/600V	503C690G05
	100A/600V	503C690G06
60	30A/600V	503C690G19
100	60A/600V	503C690G20
	100A/600V	503C690G21
	200A/600V	503C690G22

Extra Long Vari-Depth Shaft for Model A Switches

Note: Order in place of standard shaft when required.

Switch Ampere Rating	Panel Depth in Inches (mm) Long Shaft	Catalog Number
30	8.19–13.06 (208.0–331.7) ^④	2607D65G02
Special 60	8.19–13.06 (208.0–331.7) ^④	2607D65G02
60	9.41–14.3 (239.0–358.9)	2607D65G02
100	9.41–14.3 (239.0–358.9)	2607D65G02

Notes

- ^① For use with panels 5.06–8.19 inches (128.5–208.0 mm) deep.
- ^② For use with panels 5.19–9.97 inches (131.8–253.2 mm) deep.
- ^③ Order Instruction Sheet 12641.
- ^④ For panel depth of 8.19–9.94 inches (208.0–252.5 mm), a minimum of 1.75 inch must be cut from bottom of shaft.

Technical Data and Specifications

Maximum Horsepower Ratings

Fuse Clip Ratings	Maximum Horsepower Ratings								
	120 Vac		240 Vac		480 Vac		600 Vac		250 Vdc
	Standard	Time Delay	Standard	Time Delay	Standard	Time Delay	Standard	Time Delay	
30A Switch									
Unfused	3	—	7-1/2	—	20	—	25	—	5
30A/250V	1-1/2	3	3	7-1/2	—	—	—	—	5
60A/250V	3	—	5	—	—	—	—	—	5
100A/250V	3	—	5	—	—	—	—	—	5
30A/600V	—	—	—	—	5	15	7-1/2	20	5
60A/600V	—	—	—	—	15	—	20	—	5
60A Switch (and Special 60 Ampere Switch)									
Unfused	7-1/2	—	20	—	40	—	50	—	10
30A/250V	1-1/2	3	3	7-1/2	—	—	—	—	5
60A/250V	3	7-1/2	7-1/2	15	—	—	—	—	10
100A/250V	—	—	15	—	—	—	—	—	10
200A/250V ^①	—	—	15	—	—	—	—	—	—
30A/600V	—	—	—	—	5	15	7-1/2	20	5
60A/600V	—	—	—	—	15	30	15	50	10
100A/600V ^①	—	—	15	—	25	30	30	50	10
100A Switch									
Unfused	15	—	30	—	60	—	75	—	20
30A/250V	1-1/2	3	3	7-1/2	—	—	—	—	5
60A/250V	3	7-1/2	7-1/2	15	—	—	—	—	10
100A/250V	15	15	15	30	—	—	—	—	20
200A/250V	15	15	15	30	—	—	—	—	20
30A/600V	—	—	—	—	5	15	7-1/2	20	—
60A/600V	—	—	—	—	15	30	15	50	—
100A/600V	—	—	—	—	25	60	30	75	—
200A/600V	—	—	—	—	25	60	30	75	—

Note

① Does not apply to special 60A switch since these fuse clips cannot be added.

Complete Operating Mechanism—C361NE1

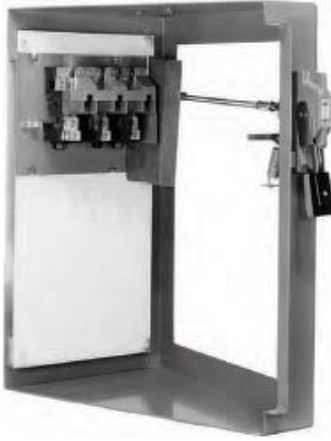

Contents

<i>Description</i>	<i>Page</i>
Product Overview	V2-T1-2
General Duty	V2-T1-25
Heavy-Duty	V2-T1-30
Heavy-Duty Double Door Safety Switch	V2-T1-39
Six-Pole Switches	V2-T1-43
Double-Throw Switches	V2-T1-46
EnviroLine Stainless Steel Switch	V2-T1-53
Window Switches	V2-T1-57
Receptacle Switches	V2-T1-60
Non-Metallic KRYDON Switch	V2-T1-62
Shunt Trip Safety Switch	V2-T1-65
NEMA 7/9—Hazardous Location Disconnect Switch	V2-T1-68
Quick-Connect Switches	V2-T1-70
Solar Disconnect Switch	V2-T1-75
Mill-Duty Rated, Heavy-Duty Safety Switch	V2-T1-77
Heavy-Duty Fusible Safety Switches Accepting CUBEFuses	V2-T1-79
Elevator Control Switch	V2-T1-82
Auxiliary Power Heavy-Duty Safety Switch	V2-T1-85
Left-Handed Safety Switch	V2-T1-89
Heavy-Duty Surge Switch	V2-T1-90
OEM Line Isolation (OLI) Switch	V2-T1-92
Pringle Bolted Pressure Switch	V2-T1-95
Type DS, Fusible and Non-Fusible	V2-T1-98
Type Visi-Flex DE-ION	V2-T1-101
Flange Mounted—Variable Depth Product Selection	V2-T1-106
Accessories	V2-T1-107
Dimensions	V2-T1-108
Flange Mounted—Fixed Depth	V2-T1-109

Flange Mounted—Variable Depth

Product Description

Type C361 disconnect switches are suitable for installation in control enclosures having a right-hand flange. Fusible disconnect switches will accept R fuses as standard. Field installable rejection kits are supplied as standard on 100 and 200A clips. For 30 and 60A rejection clips, see footnote ④ on next page. The switch is UL component recognized for use on systems with up to 200,000 rms symmetrical amperes available fault current when Class R clips are supplied.

Standards and Certifications

- UL—Component File E55492
- CSA—LR353-439



Product Selection

C361NE1



Operating Mechanism Variable Depth with Disconnect Switch—Right-Hand Mounting

Disconnect Switch Size (Amperes)	Variable Depth Mtg. Range Min./Max. (Inches) ^①	Maximum Horsepower Ratings ^②					DC Using Two Poles 250V Max.	Fuse Clip Rating (Amperes) Non-Interchangeable Type for Class H, J, K or R Type Fuses Only		Switch and Operating Mechanism Only DOES NOT Include Handle Catalog Number	Switch and Operating Mechanism with 4-Inch Handle ^③	
		AC System Volts (Motor Volts)						250V	600V		For NEMA 1 or 12 Enclosure	For NEMA 4 Enclosure
		208 (200)	240 (230)	480 (460)	600 (575)							Catalog Number
30	7 to 16	7-1/2	7-1/2	15	20	5	Non-fusible		C361NC	C361NC1	C361NC2	
							30	—	C361SC21	C361SC121 ^④	C361SC221 ^④	
							60	30	C361SC61	C361SC161 ^④	C361SC261 ^④	
60	7 to 16	15	15	30	50	10	Non-fusible		C361ND	C361ND1	C361ND2	
							60	30	C361SD22	C361SD122 ^④	C361SD222 ^④	
							—	60	C361SD62	C361SD162 ^④	C361SD262 ^④	
100	7 to 16	25	30	60	75	20	Non-fusible		C361NE	C361NE1	C361NE2	
							100	100	C361SE263	C361SE1263	C361SE2263	
200	7 to 16	40	60	125	150	40	Non-fusible		C361NF1	C361NF1	C361NF2	
							200	200	C361SF264	C361SF1264	C361SF2264	

C361H1



Handle Only

Application	Operating Handle Length in Inches (mm)	NEMA Type Enclosure	Catalog Number
For use with 30, 60, 100 and 200A disconnect switches	4.00 (101.6)	1-12	C361H1
	4.00 (101.6)	4	C361H2
	6.00 (152.4)	1-12	C361H3
	6.00 (152.4)	4	C361H4

Notes

- ① Dimension shown is from panel to flange surface.
- ② Refers to rating of switch only.
- ③ Components individually boxed and shipped in overpack carton.
- ④ For rejection clips, add Suffix Letter **R** to listed Catalog Number. Example: C361SC121**R**.

Accessories

Type C361 NEMA 12 Safety Door Hardware

Type C361 door hardware kits are designed to function with all C361 and C371 disconnect switches and circuit breaker operating mechanisms.

These kits are designed for use with small enclosures up to 40 inches (1016 mm), intermediate 40–60 inches (1016–1524 mm) or larger floor cases over 60 inches (1524 mm) to provide enclosure sealing and protection against unauthorized entry.

These kits can be used on enclosure flanges with material thickness ranging from 16 gauge through 3/16 inches with flanges on the right side only. Door hardware kits are to be installed in a commercially available enclosure. Consult the enclosure manufacturer application data for proper kit selection.

NEMA 12 Safety Door Hardware



Type C361 NEMA 12 Safety Door Hardware

Handle Length (Inches)	Catalog Number ^①
4	C361KJ4
6	C361KJ6
Roller Latch ^②	C361KR

Interlocks and Connecting Rod

Electrical Interlocks

Circuit	Catalog Number
1NO-1NC	DS200EK1
2NO-2NC	DS200EK2

Connecting Rods—Increase Maximum Allowable Depth by 5 Inches

Application	Catalog Number
Disconnect switches 30, 60, 100 and 200A Circuit breakers 150, 250 and 400A	C371CS1
Circuit breakers 600, 800 and 1200A	C371CS2

Notes

- ① The 1/4-inch x 1/2-inch standard mill rectangular locking bar is not supplied with these kits.
- ② Third roller latch for use with 4 or 6-inch handle when three-point latching is required.

1

Dimensions

Approximate Dimensions in Inches (mm)

Mounting Dimension Requirements in Inches (mm)

Disconnect Switch Type	A	B	C	D	E	F	G
30A and 60A non-fusible	See dimensions below	See dimensions below	1.56 (39.6)	0.96 (24.4)	4.00 (101.6)	3.50 (88.9)	7.12 (180.8)
30A and 60A fusible			1.56 (39.6)	0.96 (24.4)	4.00 (101.6)	3.50 (88.9)	9.75 (247.7)
100A non-fusible			1.75 (44.5)	1.10 (27.9)	5.50 (139.7)	3.38 (85.9)	7.12 (180.8)
100A fusible			1.75 (44.5)	1.10 (27.9)	5.50 (139.7)	3.38 (85.9)	11.88 (301.8)
200A non-fusible and fusible			3.34 (84.8)	0.63 (16.0)	8.50 (215.9)	1.84 (46.7)	15.50 (393.7)

Mounting Dimension Requirements

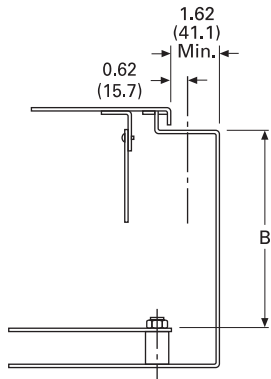
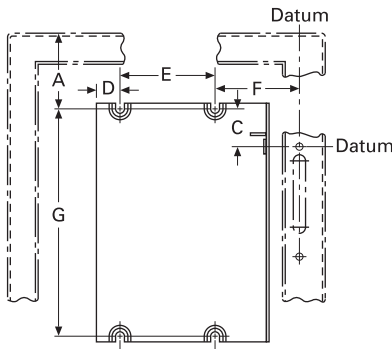

Line Lug Data

Disconnect Switch Size	Wire Size
30A	#2-14 Cu/Al
60A	#2-14 Cu/Al
100A	1/0-14 Cu/Al
200A	250 kcmil-#6 Cu/Al

Dimension A = The required wire bending spacing selected from Article 430.10 of the National Electrical Code.

Dimension B = Minimum or maximum depth from inside of flange holding operating handle to panel where disconnect switch is mounted (variable 7 to 16 inches).

Fixed Depth Application

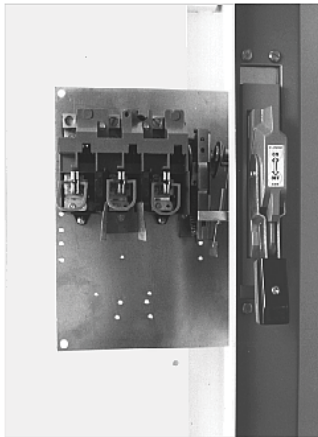

Contents

<i>Description</i>	<i>Page</i>
Product Overview	V2-T1-2
General Duty	V2-T1-25
Heavy-Duty	V2-T1-30
Heavy-Duty Double Door Safety Switch	V2-T1-39
Six-Pole Switches	V2-T1-43
Double-Throw Switches	V2-T1-46
EnviroLine Stainless Steel Switch	V2-T1-53
Window Switches	V2-T1-57
Receptacle Switches	V2-T1-60
Non-Metallic KRYDON Switch	V2-T1-62
Shunt Trip Safety Switch	V2-T1-65
NEMA 7/9—Hazardous Location Disconnect Switch	V2-T1-68
Quick-Connect Switches	V2-T1-70
Solar Disconnect Switch	V2-T1-75
Mill-Duty Rated, Heavy-Duty Safety Switch	V2-T1-77
Heavy-Duty Fusible Safety Switches Accepting CUBEFuses	V2-T1-79
Elevator Control Switch	V2-T1-82
Auxiliary Power Heavy-Duty Safety Switch	V2-T1-85
Left-Handed Safety Switch	V2-T1-89
Heavy-Duty Surge Switch	V2-T1-90
OEM Line Isolation (OLI) Switch	V2-T1-92
Pringle Bolted Pressure Switch	V2-T1-95
Type DS, Fusible and Non-Fusible	V2-T1-98
Type Visi-Flex DE-ION	V2-T1-101
Flange Mounted—Variable Depth	V2-T1-105
Flange Mounted—Fixed Depth Accessories	V2-T1-110
Technical Data and Specifications	V2-T1-110
Dimensions	V2-T1-110

Flange Mounted—Fixed Depth

Product Description

Type C361 disconnect switches are suitable for installation in control enclosures having a right-hand flange. Fusible disconnect switches will

accept R fuses as standard. Field installable rejection kits are supplied as standard on 100 and 200A clips. For 30 and 60A rejection clips, see **Page V2-T1-106**. The switch

is UL component recognized for use on systems with up to 200,000 rms symmetrical amperes available fault current when Class R clips are supplied.

- Minimum depth—flange to panel
 - 30–60A: 6.50 inches
 - 100A: 7 inches

Product Selection

Fixed Depth Application



Operating Mechanism Fixed Depth with Disconnect Switch—Right-Hand Mounting

Disconnect Switch Size (Amperes)	Maximum Horsepower Ratings ^①					DC Using Two Poles 250V Maximum	Fuse Clip Rating (Amperes) Non-Interchangeable Type for Class H, J, K or R Type Fuses Only		Switch and Operating Mechanism with 4-Inch Handle For NEMA 1 or 12 Enclosure Catalog Number
	AC System Volts (Motor Volts)				250V		600V		
	208 (200)	240 (230)	480 (460)	600 (575)					
30	7-1/2	7-1/2	15	20	5	Non-fusible		C361FNC1	
						30	—	C361FSC121 ^②	
						60	30	C361FSC161 ^②	
60	15	15	30	50	10	Non-fusible		C361FND1	
						60	30	C361FSD122 ^②	
						—	60	C361FSD162 ^②	
100	25	30	60	75	20	Non-fusible		C361FNE1	
						100	100	C361FSE1263	

Notes

^① Refers to rating of switch only.

^② For Rejection Clips, add Suffix Letter **R** to listed Catalog Number. Example: C361FSC121**R**.

Accessories

Electrical Interlocks

Circuit	Catalog Number
1NO-1NC	DS200EK1
2NO-2NC	DS200EK2

Technical Data and Specifications

Line Lug Data

Disconnect Switch Size	Wire Size
30A	#2-14 Cu/Al
60A	#2-14 Cu/Al
100A	1/0-14 Cu/Al
200A	250 kcmil-#6 Cu/Al

Dimensions

Approximate Dimensions in Inches (mm)

Frame Size

Description	A	B	C	D	E
30-60A disconnect switch	8.63 (219.2)	11.38 (289.1)	6.50 (165.1)	1.50 (38.1)	9.50 (241.3)
150A circuit breaker	8.63 (219.2)	11.38 (289.1)	6.50 (165.1)	1.50 (38.1)	9.50 (241.3)
100A disconnect switch	9.88 (251.0)	13.38 (339.9)	7.00 (177.8)	1.25 (31.8)	11.75 (298.5)
250A circuit breaker	9.88 (251.0)	13.38 (339.9)	7.00 (177.8)	1.25 (31.8)	11.75 (298.5)
400A circuit breaker	9.88 (251.0)	13.38 (339.9)	7.00 (177.8)	1.25 (31.8)	11.75 (298.5)

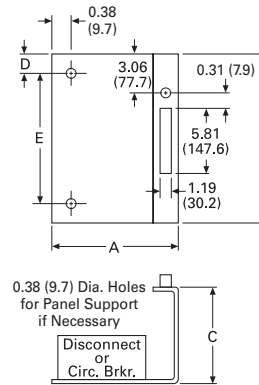

Enclosed Circuit Breaker (ECB) with Arcflash Reduction Maintenance System**Contents****Description**

	Page
Enclosed Circuit Breaker (ECB) with Arcflash Reduction Maintenance System	
Catalog Number Selection	V2-T1-112
Product Selection	V2-T1-112
Wiring Diagram	V2-T1-113
Dimensions	V2-T1-114

Enclosed Circuit Breaker (ECB) with Arcflash Reduction Maintenance System**Product Description**

Eaton's enclosed circuit breakers equipped with Arcflash Reduction Maintenance System™ technology improve safety by providing a simple and reliable method to reduce fault clearing time. Faster clearing time means less arc energy. Less arc energy exposure means improved worker safety.

The enclosed circuit breaker with Arcflash Reduction Maintenance System is a fully factory wired assembly, including an electronic trip circuit breaker, cover controls and other components that allow a customer to activate the Arcflash Reduction Maintenance System technology during maintenance. This maintenance mode is enabled by a simple lockable switch that can be incorporated into a lockout/tagout (LOTO) procedure. The resulting reduction in incident energy levels can help reduce levels of required personal protection equipment (PPE), offering an improvement to worker comfort, mobility and productivity.

Features**Standard Features**

- Digitrip 310+ trip unit with ALSI protection
- Full range, 55 A to 1200 A
- NEMA Type 1, 3R, 12, 4X
- 600 Vac maximum
- 65 kAIC maximum at 480 Vac
- Additional control relay included to allow users to enable the Arcflash Reduction Maintenance System maintenance mode via a remote input signal
- 48 W power supply
- 100 VA CPT
- Cover controls, including padlockable selector switch for Arcflash Reduction Maintenance System maintenance mode activation and blue LED indication light
- Padlockable in the OFF position ①
- Padlockable enclosure
- Three-position handle (ON/Tripped/OFF)
- Assembly is fully factory wired and ready to go out of the box
- Can be applied on three-phase and single-phase systems ②

Notes

- ① From the factory, the handle can only be locked in the OFF position and can accommodate a maximum of three padlocks. Field modification to drill the shroud can allow locking in the ON position. Check with your local AHJ for requirements. The breaker will trip as usual, even with the handle locked ON.
- ② For single-phase applications, the customer must wire using the breaker's two outside poles.

Optional Features

- Standard molded case breaker accessories available
- For ground fault applications, ALSIG protection is available
- Modifications available such as custom paint, 316-stainless enclosures, lock-on provisions, and more. Call the Flex Center at 888-329-9272 for more information

Standards and Certifications

- UL 489 (File Number E309241)
- cUL® 489 (File Number E309241)
- NEC 240.87 Compliant

**Seismic Qualifications**

- Enclosed circuit breakers exceed the requirements of Uniform Building Code (UBC) and California Code Title 24 OSP-0338-10



1.2

Switching Devices

Enclosed Circuit Breakers

1

Catalog Number Selection

Enclosed Circuit Breaker (ECB) with Arcflash Reduction Maintenance System

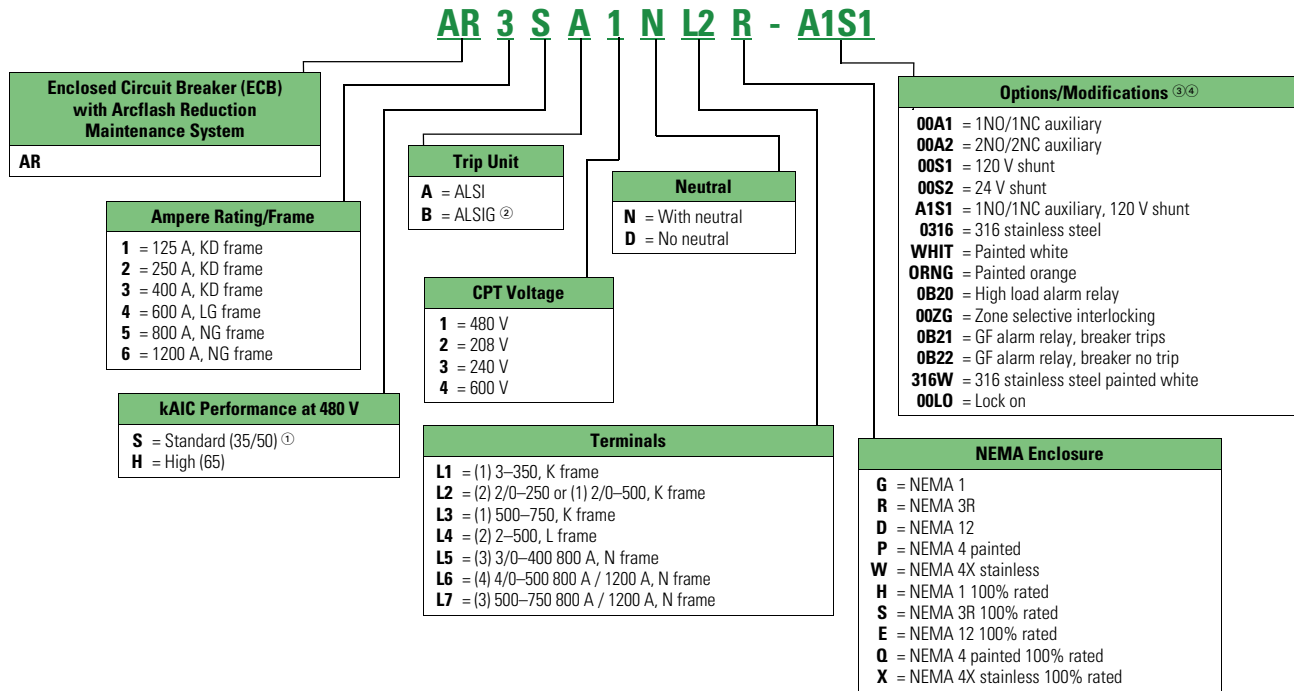

Product Selection

ECB



Short-Circuit Ratings

Breaker Frame	kAIC Ratings			Catalog Numbers
	240 V	480 V	600 V	
KD	65	35	25	AR1S, AR2S, AR3S
HKD	100	65	35	AR1H, AR2H, AR3H
LGE	65	35	18	AR4S
LGH	100	65	35	AR4H
NGS	85	50	25	AR5S, AR6S
NGH	100	65	35	AR5H, AR6H

Neutral Field Kits

Ampere Rating/ Breaker Frame	Catalog Number Prefix	Trip Unit	Neutral Assembly	Neutral Wire Range
125A KD-frame	AR1	ALSI	DS400NK	2 lugs with range (1) 750 kcmil–1/0 or (2) 300 kcmil–1/0
		ALSIG	AR1NGFCT ⑤	3 lugs with range (1) 250 kcmil–#6
250A KD-frame	AR2	ALSI	DS400NK	2 lugs with range (1) 750 kcmil–1/0 or (2) 300 kcmil–1/0
		ALSIG	AR2NGFCT ⑤	3 lugs with range (1) 250 kcmil–#6
400A KD-frame	AR3	ALSI	DS400NK	2 lugs with range (1) 750 kcmil–1/0 or (2) 300 kcmil–1/0
		ALSIG	AR3NGFCT ⑤	3 lugs with range (1) 250 kcmil–#6
600A LG-frame	AR4	ALSI	DS600NK	2 lugs with range (1) 750 kcmil–1/0 and (1) 600 kcmil–#2
		ALSIG	AR4NGFCT ⑤	3 lugs with range (1) 250 kcmil–#6
800A NG-frame	AR5	ALSI	DS800NK	2 lugs with range (4) 750 kcmil–1/0
		ALSIG	AR5NGFCT ⑤	3 lugs with range (1) 250 kcmil–#6
1200A NG-frame	AR6	ALSI	DS800NK	2 lugs with range (4) 750 kcmil–1/0
		ALSIG	AR6NGFCT ⑤	3 lugs with range (1) 250 kcmil–#6

Notes

- ① Standard = 35 kAIC for KD and LG, 50 kAIC for NG.
- ② Neutral CTs are included for ground fault protected breakers (ALSIG option).
- ③ More combinations and options are available.
- ④ Breaker accessories (shunt, UVR, etc.) can be field installed. See molded case breaker catalog section for information regarding accessories and proper installation.
- ⑤ Includes neutral and ground fault neutral sensor.

Wiring Diagram

ECB with Arcflash Reduction Maintenance System Wiring

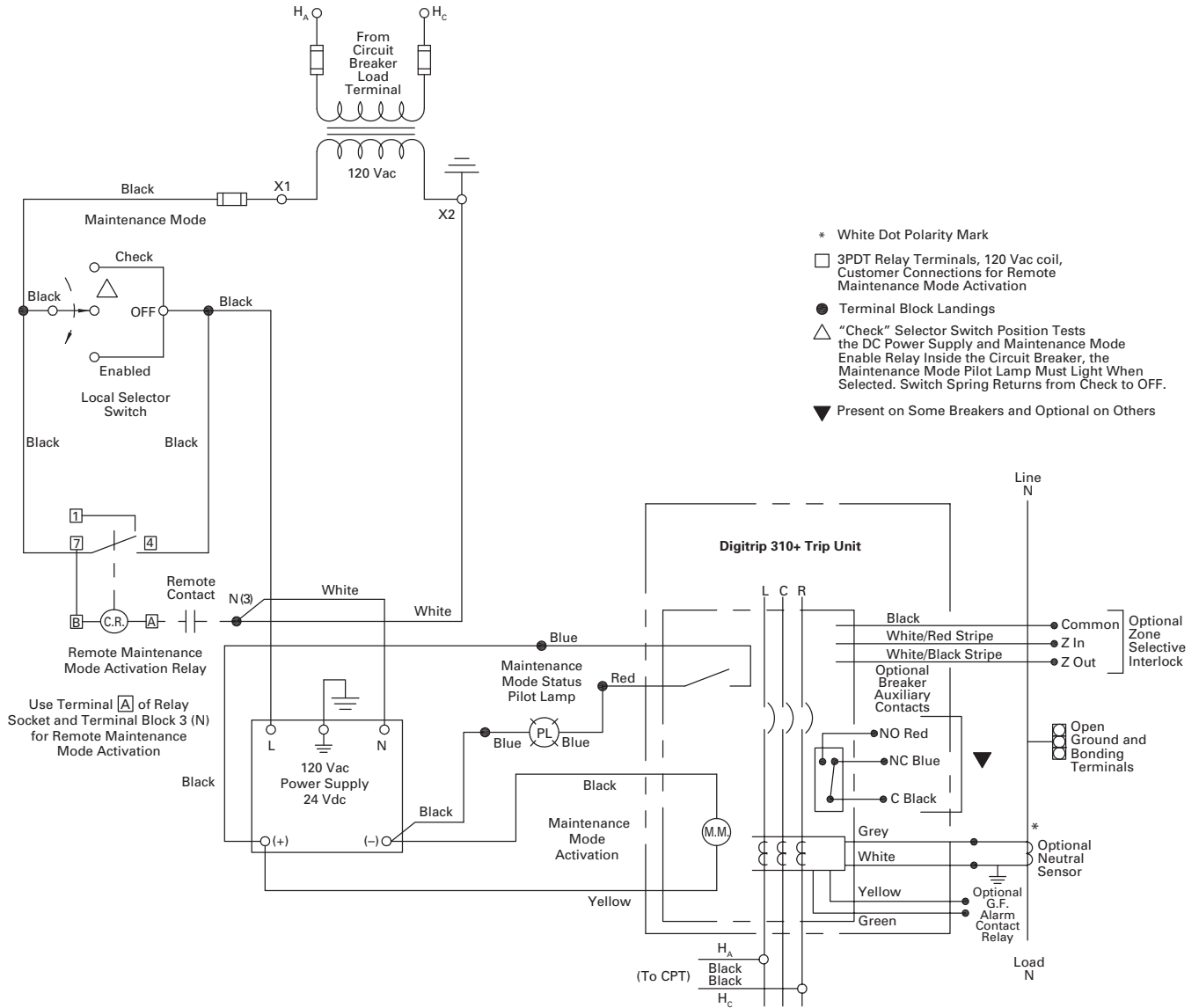

1.2

Switching Devices

Enclosed Circuit Breakers

1

Dimensions

Approximate Dimensions in Inches (mm)

ECB with Arcflash Reduction Maintenance System

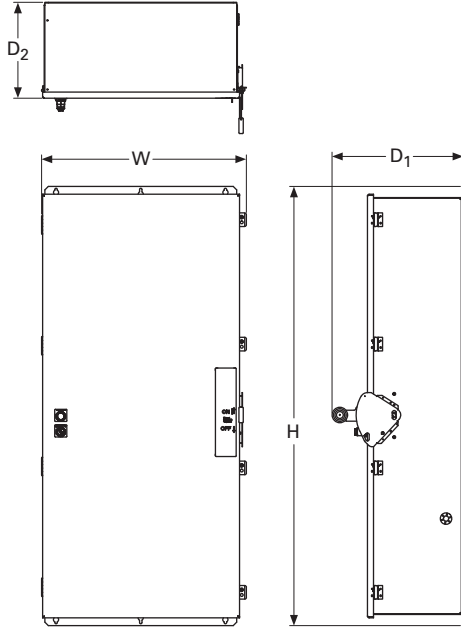

Breaker Frame	Maximum Amperage	Height (H)	Width (W)	Depth (D1)	Depth (D2)
K	400	53.63 (1362.2)	26.48 (672.6)	12.69 (322.3)	7.54 (191.5)
LG	600	53.63 (1362.2)	26.48 (672.6)	12.69 (322.3)	7.54 (191.5)
NG	1200	63.54 (1614.0)	29.63 (752.6)	18.99 (482.3)	13.87 (352.3)
K 100% rated	400	53.63 (1362.2)	26.48 (672.6)	12.69 (322.3)	7.54 (191.5)
LG 100% rated	600	53.63 (1362.2)	26.48 (672.6)	12.69 (322.3)	7.54 (191.5)
NG 100% rated	1200	70.99 (1803.2)	29.62 (752.4)	18.93 (480.8)	13.81 (350.8)

Enclosed Circuit Breakers



Contents

<i>Description</i>	<i>Page</i>
Enclosed Circuit Breakers	
Features, Benefits and Functions	V2-T1-116
Standards and Certifications.	V2-T1-116
Cross-Reference	V2-T1-117
Product Selection	V2-T1-119
Accessories	V2-T1-120
Flex Center	V2-T1-122
Technical Data and Specifications.	V2-T1-123
Dimensions	V2-T1-125

Enclosed Circuit Breakers

Product Description

- 15–1200A
- Enclosed device used to open and close a circuit

Application Description

NEMA 1 General Purpose

**Surface or Flush Mounting
15–1200A, 600 Vac, 500 Vdc**

NEMA 1 enclosed breakers are designed for indoor use in commercial buildings, apartment buildings and other areas where a general purpose enclosure is applicable. The breaker is front operable and is capable of being padlocked in the OFF position. Ratings through 1200A are listed with Underwriters Laboratories as suitable for service entrance application. Both surface and flush mounted enclosures are available.



NEMA 1 General Purpose

NEMA 3R Rainproof Surface Mounting ①

Interchangeable Hubs (through 400A) 15–1200A, 600 Vac, 500 Vdc

This general purpose outdoor service center employs a circuit breaker inside a weatherproof sheet steel enclosure to serve as a main disconnect and protective device for feeder circuits. The breaker is front operable and is capable of being padlocked in the OFF position. Ratings through 1200A are listed by Underwriters Laboratories as suitable for service entrance application.



NEMA 3R Rainproof Surface Mounting

Note

① SFDN enclosed breakers do not have a door interlock to prevent door from being opened when breaker is "ON."

NEMA 4/4X, 5 Water and Dustproof

**Stainless Steel—Type 304
Surface Mounting 15–1200A,
600 Vac, 500 Vdc**

This enclosure meets NEMA 4/4X and 5 requirements for water and dustproof applications and has no knockouts or other openings. It is particularly well suited for use in dairies, borax mines, breweries, paper mills and other process industries. The operating handle can be padlocked in the OFF position, and is interlocked to prevent the door from opening when the breaker is ON. Ratings through 1200A are Underwriters Laboratories listed as suitable for service entrance application.



NEMA 4/4X Water and Dustproof

NEMA 12 Dustproof Surface Mounting**No Knockouts or Other Openings
15–1200A, 600 Vac,
500 Vdc**

The Type 12 enclosure is designed in line with specifications for special industry application where unusually severe conditions involving oil, coolant, dust and other foreign materials exist in the operating atmosphere. The handle padlocks in the OFF position and the cover is interlocked with the handle mechanism to prevent opening the cover with the circuit breaker in the ON position. Ratings through 1200A are UL listed as suitable for service entrance application. A NEMA 12 semi-dust-tight design that includes knockouts is available. These units are rated 15–400A, 600 Vac, 500 Vdc.

**NEMA 12 Dustproof Surface Mounting****NEMA 7/9 Hazardous Location****Cast Aluminum, Explosion-proof
Surface Mounting 15–1200A,
600 Vac, 250 Vdc**

Hazardous location, Type 7: Class I, Groups B, C, D; Type 9: Class II, Groups E, F, G. This special service cast aluminum enclosure is supplied with a wide, machined flanged cover to prevent igniting outside atmospheres by arcing from inside the enclosure. Front operable, the handle padlocks in the OFF position. Enclosures rated 600A and above have lift-off hinges for ease of assembly.

Note: XFDN050B is not Group B compliant.

**NEMA 7/9 Hazardous Location****Features, Benefits and Functions**

- Side-opening door on NEMA 3R enclosures
- Padlockable in the OFF position
- Surface or flush mounted enclosures available through 400A on NEMA 1 enclosures
- Interlocked handle on NEMA 3R, 4/4X, 5 and 12 enclosures to prevent opening when the breaker is in the ON position
- Interchangeable hubs
- Numerous factory options

Standards and Certifications

- UL 489
- CSA 22.2
- NEMA 250

NEMA 1 General Purpose

- UL File No. E7819
- CSA File No. LR84319

NEMA 3R Rainproof Surface Mounting

- UL File No. E7819
- CSA File No. LR84319

NEMA 4/4X, 5 Water and Dustproof

- UL File No. E7819
- CSA File No. LR84319

NEMA 12 Dustproof Surface Mounting

- UL File No. E7819
- CSA File No. LR84319

NEMA 7/9 Hazardous Location

- UL File No. E84577
- CSA File No. LR42131-6

**Seismic Qualifications**

- Enclosed circuit breakers exceed the requirements of Uniform Building Code (UBC) and California Code Title 24 OSP-0338-10



Cross-Reference

Enclosed Circuit Breaker Competitive Catalog Numbers

NEMA Rating	Catalog Number		Square D Enclosure	Square D Breaker	Siemens		General Electric	
	Eaton Enclosure	Eaton Breaker			Siemens Enclosure	Siemens Breaker	General Electric Enclosure	General Electric Breaker
1 surface	SGDN100	GHC3100	EHB125NS	EHB34100	—	—	—	—
1 flush	—	—	EHB125NF	EHB34100	—	—	—	—
3R	RGDN100	GHC3100	EHB125NRB	EHB34100	—	—	—	—
12	JGDN100	GHC3100	—	—	—	—	—	—
4/4X	WGDN100	GHC3100	—	—	—	—	—	—
1 surface	SFDN100	EHD3100L	FA100S	FAL34100	E2N1S	ED43B100	TE100S	TED134100WL
1 flush	FFDN100	EHD3100L	FA100F	FAL34100	E2N1F	ED43B100	TE100F	TED134100WL
3R	RFDN100	EHD3100L	FA100RB	FAL34100	E2N3R	ED43B100	TE100R	TED134100WL
12/3R	—	—	FA100AWK	FAL34100	—	—	—	—
12	JFDN100	EHD3100L	—	—	E2N12	ED43B100	TE100J/SE100J	TED134100WL
4/4X	WFDN100	EHD3100L	FA100DS	FAL34100	ED6SS4	ED43B100	TE100CS/SE100CS	TED134100WL
7/9	XFDN050	EHD3050L	FA060X	FAL34060	EA	ED43B100	—	—
9	—	—	FA060Y	FAL34060	—	—	—	—
7/9	XFDN225B ①	FD3225L	FA100X	FAL34100	EB	ED43B100	—	—
9	—	—	FA100Y	FAL34100	—	—	—	—
1 surface	SFDN225 ①	FDB3150L	—	—	E2N1S	ED43B125	TE150S	TED134150WL
1 flush	FFDN225 ①	FDB3150L	—	—	E2N1F	ED43B125	TE150F	TED134150WL
3R	RFDN225 ①	FDB3150L	—	—	E2N3R	ED43B125	TE150R	TED134150WL
12	JFDN225 ①	FDB3150L	—	—	E2N12	ED43B125	—	—
4/4X	WFDN225 ①	FDB3150L	—	—	ED6SS4	ED43B125	—	—
7/9	XFDN225B ①	FDB3150L	—	—	—	—	—	—
1 surface	SFDN225 ①	FD3225L	—	—	—	—	—	—
1 flush	FFDN225 ①	FD3225L	—	—	—	—	—	—
3R	RFDN225 ①	FD3225L	—	—	—	—	—	—
12	JFDN225 ①	FD3225L	—	—	—	—	—	—
4/4X	WFDN225 ①	FD3225L	—	—	—	—	—	—
7/9	XFDN225B ①	FD3225L	—	—	—	—	—	—
1 surface	SJDN250	JDB3250	KA225S	KAL36250	F6N1S	FXD63B250	TF225S	TFJ236225WL
1 flush	FJDN250	JDB3250	KA225F	KAL36250	F6N1F	FXD63B250	TF225F	TFJ236225WL
3R	RJDN250	JDB3250	KA225RB	KAL36250	F6N3R	FXD63B250	TF225R	TFJ236225WL
12/3R	—	JDB3250	KA225AWK	KAL36250	—	—	—	—
12	JJDN250	JDB3250	—	—	F6N12	FXD63B250	TF225J/SF250J	TFJ236225WL
4/4X	WJDN250	JDB3250	KA225DS	KAL36250	FD6SS4	FXD63B250	TF225CS/SF250CS	TFJ236225WL
7/9	XJDN250B	—	KA225X	KAL36250	EC2	FXD63B250	—	—
9	—	—	KA225Y	KAL36250	—	—	—	—

Note

① Maximum wire size 4/0.

Enclosed Circuit Breaker Competitive Catalog Numbers, continued

NEMA Rating	Catalog Number		Square D		Siemens		General Electric	
	Eaton Enclosure	Breaker	Enclosure	Breaker	Enclosure	Breaker	Enclosure	Breaker
1 surface	SKDN400 ①	KDB3400	LA400S	LAL36400	J6N1	JXD63B400	TJ400S/SG400S	TJK436400WL
1 flush	FKDN400 ①	KDB3400	LA400F	LAL36400	—	—	TJ400F/SG400F	TJK436400WL
3R	RKDN400 ①	KDB3400	LA400R	LAL36400	J6N3R	JXD63B400	TJ400R/SG400R	TJK436400WL
12/3R	—	—	LA400AWK	LAL36400	—	—	—	—
12	JKDN400 ①	KDB3400	—	—	J6N12	JXD63B400	TJ400J/SG400J	TJK436400WL
4/4X	WKDN400 ①	KDB3400	LA400DS	LAL36400	—	—	TJ400CS/SG400CS	TJK436400WL
7/9	XKDN400B ①②	KDB3400	—	—	EE	JXD63B400	—	—
1 surface	SLDN600	LDB3600	MA1000S	MAL36600	LD6N1	LXD63B600	TJ600S/SG600S	TJK636600WL
1 flush	—	—	MA1000F	MAL36600	—	—	TJ600F/SG600F	TJK636600WL
3R	RLDN600	LDB3600	—	—	LD6N3R	LXD63B600	TJ600R/SG600R	TJK636600WL
12/3R	—	—	MA1000AWK	MAL36600	—	—	—	—
12	JLDN600	LDB3600	—	—	LD6N12	LXD63B600	TJ600J/SG600J	TJK636600WL
4/4X	WLDN600	LDB3600	MA1000DS	MAL36600	LD6SS4	LXD63B600	TJ600CS	TJK636600WL
7/9	XMCN800B	LDB3600	—	—	ED6	LXD63B600	—	—
1 surface	SNDN1200	MDL3800	MA1000S	MAL36800	LMD1	MXD63B800	TK4V1200S	TKMA836800WL
1 flush	—	—	MA1000F	MAL36800	—	—	TK4V1200F	TKMA836800WL
3R	RNDN1200	MDL3800	—	—	LMD3R	MXD63B800	TKV41200R	TKMA836800WL
12/3R	—	—	MA1000AWK	MAL36800	—	—	—	—
12	JNDN1200	MDL3800	—	—	LMD12	MXD63B800	TK4V1200J/SK1200	TKMA836800WL
4/4X	WNDN1200	MDL3800	MA1000DS	MAL36800	—	—	—	—
7/9	XMCN800B	MDL3800	—	—	—	—	—	—
1 surface	SNDN1200	ND312T33W	MA1000S	MAL361000	—	—	—	—
1 flush	—	—	MA1000F	MAL361000	—	—	—	—
3R	RNDN1200	ND312T33W	—	—	—	—	—	—
12/3R	—	—	MA1000AWK	MAL361000	—	—	—	—
12	JNDN1200	ND312T33W	—	—	—	—	—	—
4/4X	WNDN1200	ND312T33W	MA1000DS	MAL361000	—	—	—	—
1 surface	SNDN1200	ND312T33W	—	—	MND61	NXD63B120	TK4V1200S	TKMA31200WL
12	—	—	—	—	—	—	TK4V1200F	TKMA31200WL
3R	RNDN1200	ND312T33W	—	—	MND63	NXD63B120	TKV41200R	TKMA31200WL
1 surface	—	—	NA1200AWK	NAL361200	—	—	—	—
12	JNDN1200	ND312T33W	—	—	MND612	NXD63B120	TK4V1200J/SK1200	TKMA31200WL
4/4X	WNDN1200	ND312T33W	—	—	—	—	—	—
7/9	XNDN1200B ②	ND312T33W	—	—	—	—	—	—

Notes

① Maximum wire size 500 kcmil.

② Through-feed only.

Product Selection

1. Use the data on **Page V2-T1-129** to determine type of enclosure required.
2. Use the data on **Page V2-T1-123** and **V2-T1-124** to determine circuit breaker required.
3. **Pages V2-T1-125** through **V2-T1-131** include rough-in dimensional information.

Enclosure Only—Series C Breakers

Breaker Frame	Breaker Ampere Range	Enclosure	
		NEMA Class	Catalog Number
Series C Breakers			
GHC, GD (two- and three-pole only) GHCGFEP (single-pole only)	15–100	1 surface	SGDN100 ①
		3R	RGDN100
		12	JGDN100
		4/4X, 5 stainless steel	WGDN100
EHD, FD, FDB, HFD, ED, EDH, EDB, EDS, FDC, FDE, HFDE, HFDDC	15–100	1 surface	SFDN100
		1 flush	FFDN100
		3R	RFDN100
		12	JFDN100
		4/4X, 5 stainless steel	WFDN100
EHD, FD, FDB, EHD, FD, FDB	15–50	7/9 cast aluminum	XFDN050B
HFD, FDC, EHD, FD, FDB	60–225 ②	7/9 cast aluminum	XFDN225B
FD, FDB, HFD, ED, EDH, EDC, FDC (15–225 A) EDB, EDS, FDE, HFDE, FDCE, HFDDC	125–225	1 surface	SFDN225
		1 flush	FFDN225
		3R	RFDN225
		12	JFDN225
		4/4X, 5 stainless steel	WFDN225
JD, JDB, HJD, JDC	125–250	1 surface	SJDN250
		1 flush	FJDN250
		3R	RJDN250
		12	JJDN250
		4/4X, 5 stainless steel	WJDN250
JD, JDB, HJD, JDC	125–250	7/9 cast aluminum	XJDN250B
KD, KDB, HKD, KDC, DK HKDB ③, CKD, CHKD, KDB, HKDDC	125–400	1 surface	SKDN400
		1 flush	FKDN400
		3R	RKDN400
		12	JKDN400
		4/4X, 5 stainless steel	WKDN400

Enclosure Only—Series C Breakers, continued

Breaker Frame	Breaker Ampere Range	Enclosure	
		NEMA Class	Catalog Number
Series C Breakers, continued			
KD, KDB, HKD, KDC, DK LGE, LGS, LGH	125–400 250–600	7/9 cast aluminum	XKDN400B
		1 surface	SLG630
		3R	RLG630
		12	JLG630 ⑤
		4/4X, 5 stainless steel	WLG630
LD, LDB, HLD ④, HLDB, LDCB	300–600	1 surface	SLDN600
		3R	RLDN600
		12	JLDN600
		4/4X, 5 stainless steel	WLDN600
		7/9 cast aluminum	XLDN600B
LD, LDB, HLD	300–600	7/9 cast aluminum	XMKN800B
MDL, HMDL	400–800		
MDL, HMDL, ND, HND ④ MPS, MPH, HMDL, MDLB, HMDLDC, HMDLB, MDLPV Molded Case Switches (w/ WK suffix)— MDL, MDLB, HMDL, HLDLC, ND, HND, HMDLDC Molded Case Switches (w/ K suffix)— MPS Molded Case Switches (w/ SE suffix)— NGK	400–1200	1 surface	SNDN1200
		3R	RNDN1200
		12	JNDN1200
		4/4X, 5 stainless steel	WNDN1200
ND, HND	—	7/9 cast aluminum	XNDN1200B

Enclosure Only—Series G Breakers

Breaker Frame	Breaker Ampere Range	Enclosure	
		NEMA Class	Catalog Number
Series G Breakers			
LGE, LGS, LGH	250–600	1 surface	SLG630 ⑥
		3R	RLG630 ⑥
		12	JLG630 ⑥
		4/4X, 5 st. steel	WLG630 ⑥
NG, NGS, NGH	320–1200	1 surface	SNDN1200
		3R	RNDN1200
		12	JNDN1200
		4/4X, 5 st. steel	WNDN1200

Notes

- ① Suitable for use with single-pole breaker. Base mounting plate kit. QCCBP required.
- ② Maximum wire size: 4/0.
- ③ Not applicable for XKDN400B.
- ④ Short-circuit ratings are limited for high interrupting rated breakers. Refer to **Page V2-T1-123**.
- ⑤ Can be field converted to NEMA Type 3R.
- ⑥ Three- or four-pole.

Enclosure Only—Earth Leakage Breakers

Breaker Frame	Breaker Ampere Range	Enclosure NEMA Class	Catalog Number
Earth Leakage Breakers			
ELFD, ELHFD and ELFDC (three-pole only)	15–100	1 surface	SFD100E
		1 flush	FFD100E
		3R	RFDN100E
		12	JFDN100E
		4/4X	WFDN100E
LGE, LGS, LGH used with ELLBN	250–600	1 surface	SLG630E
		3R	RLG630
		12	JLG630 ①
		4/4X, 5 st. steel	WLG630

Enclosure Only Catalog Numbers for 100% Rated Circuit Breakers

Breaker Frame ②	Breaker Ampere Range	Enclosure NEMA Class	Catalog Number
CKD, CHKD	125–400	1 surface	SKDN400
		1 flush	FKDN400
		3R	RKDN400
		12	JKDN400
		12K	DKDN400
		4/4X, 5 st. steel	WKDN400
		7/9 cast alum.	XKDN400B
LGE...C ③ LGS...C ③ LGH...C ③	250–600	1 surface	SLG630
		3R	RLG630
		12	JLG630
		4/4X, 5 st. steel	WLG630
CMDL, CHMDL	400–800	1 surface	SCNDN1200
		3R	RCNDN1200
CND ④, CHND ④, CNDC ④⑤, NGH...C ④⑤	1200	1 surface	SCNDN1200
		3R	RCNDN1200

Accessories

Nameplates Applied

Customer must provide nameplate legend at the time of order.

Key Interlock Systems

Interlocks are used to prevent an authorized operation. Before system construction can begin, the following information must be known:

1. User—name, address and telephone number.
2. Complete lock scheme required.

Separate Ground Lug

Only included on RFDN100, SFDN100 and LG Frame N1, N3R, N4X, N12.





Special Paint Finish

Contact the Safety Switch Flex Center (1-888-329-9272) or FlexSwitches@eaton.com.

Stainless Steel Flush Covers

Frames: P, J and K.

Assembled Enclosed Circuit Breakers

Accessories	Modifications	Breaker Frame	Description
Auxiliary switches (specify voltage and Hz)		G, F, J, K, L, M, N	1A, 1B
		G, F, J, K, L, M, N	2A, 2B
		K, L, M, N	3A, 3B
		R	1A, 1B
Shunt trips (specify voltage and Hz)		G, F, J, K, L, M, N, R	—
Alarm switches (specify voltage and Hz)		G, F, J, K, L, M, N	1 Make, 1 Break
		F, K, L, M, N	2 Make, 2 Break
Undervoltage release (specify voltage and Hz)		G, F, J, K, L, M, N, R	—

Electronic Trip Options

Frame Type	Number of Poles	Description
KD, HKD	3	RMS 310 LS
		RMS 310 LSI
		RMS 310 LSG ⑥
		RMS 310 LSIG ⑥
LD, HLD	3	RMS 310 LS
		RMS 310 LSI
		RMS 310 LSG ⑥
		RMS 310 LSIG ⑥
MDL, HMDL	3	RMS 310 LS
		RMS 310 LSI
		RMS 310 LSG ⑥
		RMS 310 LSIG ⑥
ND	3	RMS 310 LS
		RMS 310 LSI
		RMS 310 LSG ⑥
		RMS 310 LSIG ⑥
RD	3	RMS 310 LS
		RMS 310 LSI
		RMS 310 LSG
		RMS 310 LSIG
		RMS 510 LS
		RMS 610 LS
		RMS 810 LS
		RMS 910 LS

Notes

- ① Can be field converted to NEMA Type 3R.
- ② Breaker frames include both thermal magnetic and electronic trip versions.
- ③ Cu conductors only.
- ④ Cu conductors only, 90 °C wire sized at 75 °C ampacity. Conductor extensions and barriers required.
- ⑤ Maximum interruption ratings as follows, 100 kAIC at 240 Vac, 65 kAIC at 480 Vac, 35 kAIC at 600 Vac, 30 kAIC at 250 Vdc, 30 kAIC at 500 Vdc.
- ⑥ Ground fault application not available with NEMA 7/9. Contact Eaton's Customer Support Center.

Raintight Hubs

All rainproof enclosures 30–400A are shipped with plate over cutout. Hubs are not supplied with screws on 30–400A enclosures. Use screws from plate.

Raintight Hubs**Raintight Tubs**

Hubs	Hub Diameter		Catalog Number
	Inches	mm	
Small			
For use with RGDN and RFDN	0.75	19.1	DS075H1
	1.00	25.4	DS100H1
	1.25	31.8	DS125H1
	1.50	38.1	DS150H1
	2.00	50.8	DS200H1
Large			
For use with RJDN. RKDN has two cutouts	2.00	50.8	DS200H2
	2.50	63.5	DS250H2
	3.00	76.2	DS300H2
Required if using small DS hubs on RJDN and RKDN enclosures.			DS900AP

Breather and Drain, Hazardous Enclosures

A Universal Breather/Drain Fitting is installed in the top of an enclosure to provide ventilation to minimize condensation and in the bottom to allow drainage of accumulated condensation while maintaining explosion-proof integrity.

Type	Compliance		Conduit Opening	Catalog Number
	NEMA 7	NEMA 9		
BD	Class I, Groups C, D; Class I, Zone 1, Group IIB	Class II, Groups F, G	1/2	XPBD2
DBB	Class I, Groups B, C, D; Class I, Zone 1, Group IIB + Hydrogen	Class II, Groups E, F, G	1/2	XPDBB50

Neutral Kits, Insulated and Groundable

Maximum Enclosure Rating (A)	Main Lug Size Cu/Al	Catalog Number
100 SFDN100 RFDN100	(1) 14–1/0	DH100NK
100 (all others)	(1) 14–1/0	INK100
250	(1) 4–350 kcmil	INK250
400	(1) 4–600 kcmil or (2) 1/0–250 kcmil	INK400
600	(2) 250–500 kcmil	INK600
1200	(4) 3/0–750 kcmil	DS800NK ①

Note

① For use with 800 A and 1200 A M and N frame, and 100% rated.

Modifications

Allowable accessory combinations can be reviewed in Eaton's Circuit Breaker Product Guide: PG.74.A.01.T.E. Verify final application with the Customer Support Center.

Flex Center

Introduction

The Safety Switch Flex Center is a special facility at the site of our Cleveland, Tennessee, plant that is dedicated to providing customized enclosed circuit breakers that meet customers' challenging applications.

The Flex Center is a solutions center that provides real value:

- A dedicated and knowledgeable engineering/manufacturing/customer service team to meet your needs
- A production facility stocked with a full arsenal of equipment to get the job done
- The industry's shortest lead-time
- Easy ordering through our distributors
- Factory-installed modifications include (but are not limited to) the following:
 - Special size enclosure
 - Special nameplates
 - Stainless steel flush cover
 - Special paint
 - Lock-on provisions
 - Neutral assemblies—factory installed
 - Equipment ground lugs—factory installed
 - Cover control (pilot lights, pushbuttons, selector switches, etc.)
 - Factory-installed G-Frame breakers
- For application, availability or pricing questions, contact the Safety Switch Flex Center at **1-888-329-9272** or FlexSwitches@eaton.com

Satellite Plants

Atlanta

7000 Highlands Parkway SE
Suite 102
Smryna, GA 30082
678.309.4260

Baltimore

7451 Coca Cola Drive
Suite C
Hanover, MD 21076
410.796.7777

Chicago

230 Windy Point Drive
Glendale Heights, IL 60139
630.260.6303

Cleveland

12875 Corporate Drive
Unit E
Parma, OH 44130
216.265.3284

Cleveland

Safety Switches Flex Center
3990 Old Tasso Road NE
Cleveland, TN 37312
888.329.9272

Dallas

631 Westport Parkway
Suite 100
Grapevine, TX 76051
817.251.6733

Denver

2450 Airport Road
Suite C
Aurora, CO 80011
303.366.2080

Hartford

40A International Drive
Windsor, CT 06095
860.298.1305

Houston

14825 Northwest Freeway
Suite 100
Houston, TX 77040
713.744.7530

Los Angeles—MCC

13039 Crossroads Pkwy S
City of Industry, CA 91746
562.944.6413

Los Angeles—P&S

13201 Dahlia Street
Suite 300
Fontana, CA 92337
919.428.8903

Nashville

1421 Gould Blvd
Suite C
La Vergne, TN 37086
615.287.3200

Phoenix

560 N 54th Street
Suite 1
Chandler, AZ 85226
480.449.4222

Portland

26850 SW Kinsman Road
Wilsonville, OR 97070
503.582.2700

Raleigh

9400 Globe Center Drive
Suite 121
Morrisville, NC 27560
919.544.7074

St. Louis

56 Soccer Park Road
Fenton, MO 63026
636.717.3500

San Francisco

20923 Cabot Boulevard
Hayward, CA 94545
510.784.8981

Seattle

1604 15th Street SW
Suite 114
Auburn, WA 98001
253.833.5021

Westampton

96 Stemmers Lane
Westampton, NJ 08060
609.835.4230

Satellite Service Locations

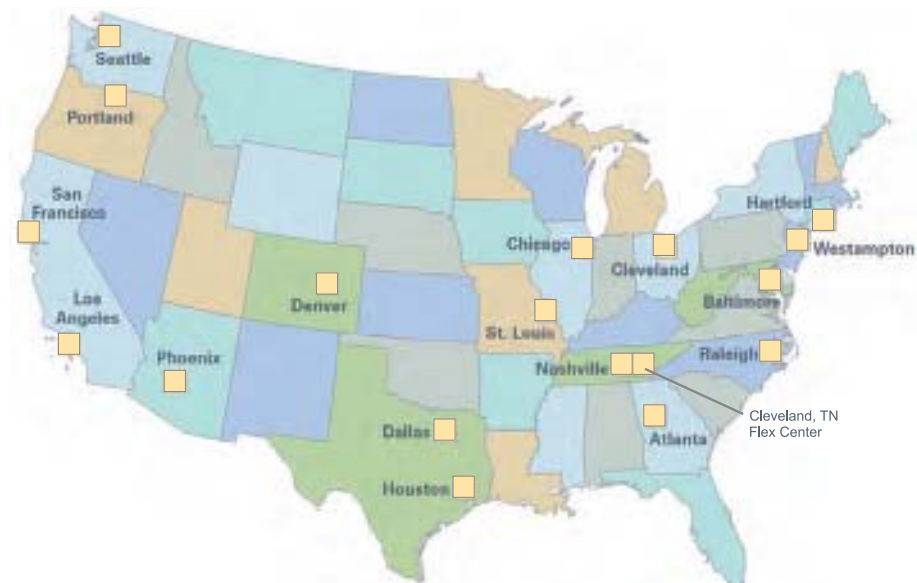

Technical Data and Specifications

Industrial Circuit Breaker Selection

Circuit Breaker Type	Continuous Ampere Rating at 40°C	Number of Poles	Vac	Vdc	Type of Trip ^①	Federal Spec. W-C-375b	UL Listed Interrupting Rating rms Symmetrical Amperes						Vdc Ratings ^②		
							Vac Ratings						125	250	125/250
G-Frame															
GHC	15–100	1	120	125	N.I.T.U.	12c, 13a	65,000	—	—	—	—	—	14,000	—	—
GHC	15–100	2, 3	240	125/250	N.I.T.U.	13b	—	—	65,000	—	—	—	—	—	14,000
GHC	15–100	1	277	125	N.I.T.U.	12c, 13a	—	—	—	14,000	—	—	14,000	—	—
GHC	15–100	2, 3	277/480	215/250	N.I.T.U.	13b	—	—	—	14,000	14,000	—	—	—	14,000
GD	15–100	3	480	250	N.I.T.U.	13b	—	—	65,000	—	22,000	—	—	10,000	—
F-Frame															
ED	100–225	2, 3	240	125	N.I.T.U.	12b	—	—	65,000	—	—	—	10,000	—	—
EDH	100–225	2, 3	240	125	N.I.T.U.	14b	—	—	100,000	—	—	—	10,000	—	—
EDC	100–225	2, 3	240	125	N.I.T.U.	1	—	—	200,000	—	—	—	10,000	—	—
EHD	15–100	1	277	125	N.I.T.U.	13a	—	—	—	14,000	—	—	10,000	—	—
EHD	15–100	2, 3	480	250	N.I.T.U.	13b	—	—	18,000	—	14,000	—	—	10,000	—
FDB	15–150	2, 3	600	250	N.I.T.U.	18a	—	—	18,000	—	14,000	14,000	—	10,000	—
FDB	15–150	4	600	250	N.I.T.U.	③	—	—	18,000	—	14,000	14,000	—	10,000	—
FD	15–225	1	277	125	N.I.T.U.	13a	—	—	—	25,000	—	—	10,000	—	—
FD	15–225	2, 3	600	250	N.I.T.U.	22a	—	—	65,000	—	25,000	18,000	—	10,000	—
FD	15–225	4	600	250	N.I.T.U.	③	—	—	65,000	—	25,000	18,000	—	10,000	—
HFD	15–225	1	277	125	N.I.T.U.	13a	—	—	—	65,000	—	—	10,000	—	—
HFD	15–225	2, 3	600	250	N.I.T.U.	22a	—	—	100,000	—	65,000	25,000	—	20,000	—
HFD	15–225	4	600	250	N.I.T.U.	③	—	—	100,000	—	65,000	25,000	—	20,000	—
FDC	15–225 ^④	2, 3	600	250	N.I.T.U.	24a	—	—	200,000	—	100,000	35,000	—	20,000	—
FDC	15–225	4	600	250	N.I.T.U.	③	—	—	200,000	—	100,000	35,000	—	20,000	—
J-Frame															
JDB	70–250	2, 3	600	250	N.I.T.U.	22a	—	—	65,000	—	35,000	18,000	—	10,000	—
JD	70–250	2, 3, 4	600	250	I.T.U.	22a	—	—	65,000	—	35,000	18,000	—	10,000	—
HJD	70–250	2, 3, 4	600	250	I.T.U.	22a	—	—	100,000	—	65,000	25,000	—	22,000	—
JDC	70–250	2, 3, 4	600	250	I.T.U.	22a	—	—	200,000	—	100,000	35,000	—	22,000	—
K-Frame															
DK	250–400	2, 3	240	250	N.I.T.U.	14b	—	—	65,000	—	—	—	—	10,000	—
KDB	100–400	2, 3	600	250	N.I.T.U.	23a	—	—	65,000	—	35,000	25,000	—	10,000	—
KD	100–400	2, 3, 4	600	250	I.T.U.	23a	—	—	65,000	—	35,000	25,000	—	10,000	—
HKD	100–400	2, 3, 4	600	250	I.T.U.	23a	—	—	100,000	—	65,000	35,000	—	22,000	—
KDC	100–400	2, 3, 4	600	250	I.T.U.	23a	—	—	200,000	—	100,000	50,000	—	22,000	—
LG-Frame															
LGE	250–600	3, 4	600	250	I.T.U.	23a	—	—	65,000	—	35,000	18,000	—	22,000	—
LGS	250–600	3, 4	600	250	I.T.U.	23a	—	—	85,000	—	50,000	25,000	—	22,000	—
LGH	250–600	3, 4	600	250	I.T.U.	23a	—	—	100,000	—	65,000	35,000	—	42,000	—

Notes

- ① N.I.T.U. is non-interchangeable trip unit and I.T.U. is interchangeable trip unit.
 ② Two-pole circuit breaker, or two poles of three-pole circuit breaker at 250 Vdc.
 ③ Not defined in W-C-375b.
 ④ Not suitable for use with 100A enclosures.

Industrial Circuit Breaker Selection, continued

Circuit Breaker Type	Continuous Ampere Rating at 40°C	Number of Poles	Vac	Vdc	Type of Trip ^①	Federal Spec. W-C-375b	UL Listed Interrupting Rating rms Symmetrical Amperes						Vdc Ratings ^②		
							Vac Ratings						125	250	125/250
							120	120/240	240	277	480	600			
L-Frame															
LDB	300–600	2, 3	600	250	N.I.T.U.	23a	—	—	65,000	—	35,000	25,000	—	22,000	—
LD	300–600	2, 3, 4	600	250	I.T.U.	23a	—	—	65,000	—	35,000	25,000	—	22,000	—
HLD ^③	300–600	2, 3, 4	600	250	I.T.U.	23a	—	—	100,000	—	65,000	35,000	—	25,000	—
M-Frame															
MDL	300–800	2, 3	600	250	I.T.U.	23a	—	—	65,000	—	50,000	25,000	—	22,000	—
HMDL ^④	300–800	2, 3	600	250	I.T.U.	23a	—	—	100,000	—	65,000	35,000	—	25,000	—
N-Frame															
ND	600–1200	3, 4	600	—	N.I.T.U.	23a	—	—	65,000	—	50,000	25,000	—	—	—
HND ^④	600–1200	3, 4	600	—	N.I.T.U.	23a	—	—	100,000	—	65,000	35,000	—	—	—
R-Frame															
RD	800–2500	3, 4	600	—	N.I.T.U.	24a	—	—	125,000	—	65,000	35,000	—	—	—

Notes

- ① N.I.T.U. is non-interchangeable trip unit and I.T.U. is interchangeable trip unit.
 ② Two-pole circuit breaker, or two poles of three-pole circuit breaker at 250 Vdc.
 ③ HLD: NEMA 1 enclosed: 240 Vac = 100 kA, 480 Vac = 65 kA, 600 Vac = 35 kA, 250 Vdc = 20 kA, 500 Vdc = 25 kA.
 NEMA 3R enclosed: 240 Vac = 65 kA, 480 Vac = 50 kA, 600 Vac = 25 kA, 250 Vdc = 20 kA, 500 Vdc = 25 kA.
 ④ HMDL and HND: NEMA 1 and 3R enclosed: 240 Vac = 100 kA, 480 Vac = 65 kA, 600 Vac = 35 kA, 250 Vdc = 30 kA, 500 Vdc = 30 kA.

Dimensions

Approximate Dimensions in Inches (mm)

NEMA 1, 12, 3R**Note:** Not to be used for construction purposes unless approved.**NEMA 1 Surface Mounted**

Frame	Maximum Amperes	A	B	C	D	E	F	Approximate Weight in Lbs (kg)
G	100	17.50 (444.5)	8.56 (217.4)	6.28 (159.5)	13.03 (331.0)	1.20 (30.5)	17.19 (436.6)	12 (5)
F ^①	100	19.13 (485.9)	9.13 (231.9) ^③	5.20 (132.1)	17.00 (431.8)	N/A ^④	18.81 (477.8)	13 (6)
Earth leakage	100	23.25 (590.6)	8.56 (217.4)	6.28 (159.5)	18.75 (476.3)	1.20 (30.5)	22.94 (582.7)	15 (7)
F ^②	225	23.25 (590.6)	8.56 (217.4)	6.28 (159.5)	18.75 (476.3)	1.20 (30.5)	22.94 (582.7)	15 (7)
J	250	34.70 (881.4)	10.92 (277.4)	7.20 (182.9)	30.00 (762.0)	1.88 (47.8)	34.39 (873.5)	31 (14)
K ^⑤	400	38.81 (985.8)	11.06 (280.9)	10.94 (277.9)	34.00 (863.6)	1.25 (31.8)	38.50 (977.9)	53 (24)
LG	600	51.06 (1296.9)	21.87 (555.5)	9.96 (253.0)	51.63 (1311.5)	1.94 (49.3)	50.13 (1273.3)	90 (41)
Earth leakage	600	51.06 (1296.9)	21.87 (555.5)	9.96 (253.0)	51.63 (1311.5)	1.94 (49.3)	50.13 (1273.3)	90 (41)
L	600	45.88 (1165.4)	14.31 (363.5)	12.38 (314.5)	46.56 (1182.6)	1.91 (48.5)	45.56 (1157.2)	81 (37)
M, N	1200	61.22 (1555.0)	21.44 (544.6)	15.41 (391.4)	61.84 (1570.7)	1.97 (50.0)	60.91 (1547.1)	178 (81)
M, N ^⑥	400–1200	67.82 (1722.6)	21.41 (543.8)	15.53 (394.5)	69.32 (1760.7)	1.97 (50.0)	68.69 (1744.7)	128 (58)

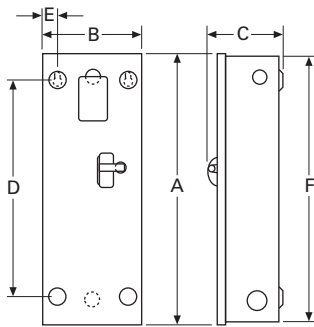
NEMA 1 Surface Mounted**Notes**

- ① SFDN100 Series "B" released 9/15/01.
- ② Maximum wire size: 4/0.
- ③ Total width, including door clip is 9.95 inches (253 mm).
- ④ Single centered mounting hole provided.
- ⑤ Maximum wire size: 500 kcmil.
- ⑥ 100% rated breakers.

1.2

Switching Devices

Enclosed Circuit Breakers

1

Approximate Dimensions in Inches (mm)

NEMA 1 Flush Mounted

Frame	Maximum Amperes	A	B	C	D	E	F	Approximate Weight in Lbs (kg)
F	100	18.81 (477.8)	9.72 (246.9)	6.28 (159.5)	13.03 (331.0)	1.86 (47.2)	18.50 (469.9)	12 (5)
Earth leakage	100	24.56 (623.8)	9.72 (246.9)	6.28 (159.5)	18.75 (476.3)	1.86 (47.2)	24.25 (616.0)	15 (7)
F ^①	225	24.56 (623.8)	9.72 (246.9)	6.28 (159.5)	18.75 (476.3)	1.86 (47.2)	24.25 (616.0)	15 (7)
J	250	36.02 (914.9)	12.23 (310.6)	7.20 (182.9)	30.00 (762.0)	1.88 (47.8)	35.70 (906.8)	32 (15)
K ^②	400	40.13 (1019.3)	12.38 (314.5)	10.94 (277.9)	34.00 (863.6)	2.94 (74.7)	39.81 (1011.2)	53 (24)

NEMA 1 Flush Mounted

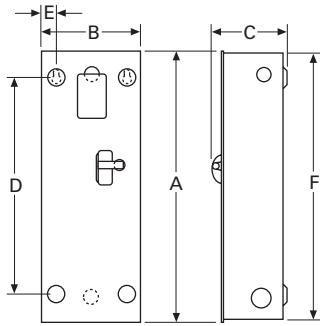

NEMA 1 Surface Mounted SFDN100 Series "B"

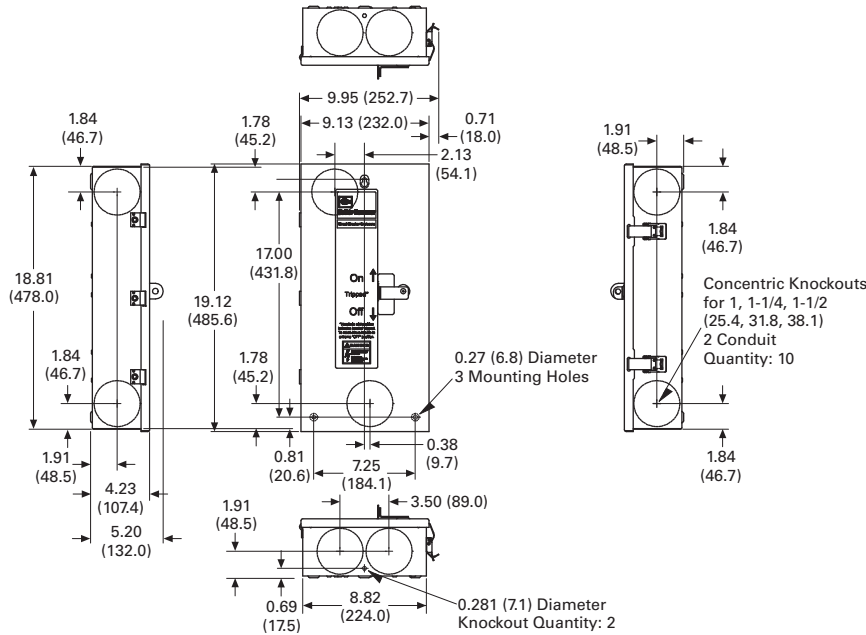

Notes

- ① Maximum wire size: 4/0.
- ② Maximum wire size: 500 kcmil.

Approximate Dimensions in Inches (mm)

NEMA 12 Dustproof

Frame	Maximum Amperes	A	B	C	D	E	Approximate Weight in Lbs (kg)
G, F	100	19.91 (505.7)	9.16 (232.7)	9.31 (236.5)	18.53 (470.7)	1.70 (43.2)	16 (7)
Earth leakage	100	19.91 (505.7)	9.16 (232.7)	9.31 (236.5)	18.53 (470.7)	1.70 (43.2)	19 (9)
FBP, FCL	100	25.66 (651.8)	9.16 (232.7)	9.31 (236.5)	24.28 (616.7)	1.70 (43.2)	19 (9)
F ^①	225	25.66 (651.8)	9.16 (232.7)	9.31 (236.5)	24.28 (616.7)	1.70 (43.2)	19 (9)
J	250	37.53 (953.3)	11.88 (301.8)	10.22 (259.6)	35.77 (908.6)	1.94 (49.3)	37 (17)
K ^②	400	41.69 (1058.9)	12.31 (312.7)	14.06 (357.1)	39.94 (1014.5)	1.97 (50.0)	58 (26)
LG	600	53.37 (1355.6)	23.06 (585.7)	14.10 (358.1)	51.63 (1311.4)	1.94 (49.3)	94 (43)
Earth leakage	600	53.37 (1355.6)	23.06 (585.7)	14.10 (358.1)	51.63 (1311.4)	1.94 (49.3)	94 (43)
L	600	48.31 (1227.1)	15.56 (395.2)	15.50 (393.7)	46.56 (1182.6)	1.92 (48.8)	84 (38)
NBP	800	63.59 (1615.2)	22.63 (574.8)	17.63 (447.8)	—	—	110 (50)
M, N	1200	63.59 (1615.2)	22.63 (574.8)	17.63 (447.8)	61.84 (1570.7)	1.97 (50.0)	175 (80)
G, F	100	19.91 (505.7)	9.16 (232.7)	9.31 (236.5)	—	—	16 (7)
Earth leakage	100	19.91 (505.7)	9.16 (232.7)	9.31 (236.5)	—	—	19 (9)
FBP, FCL	100	25.66 (651.8)	9.16 (232.7)	9.31 (236.5)	—	—	19 (9)
F ^①	225	25.66 (651.8)	9.16 (232.7)	9.31 (236.5)	—	—	19 (9)
J	250	37.53 (953.3)	11.88 (301.8)	10.22 (259.6)	—	—	37 (17)
K ^②	400	41.69 (1058.9)	12.31 (312.7)	14.06 (357.1)	—	—	58 (26)

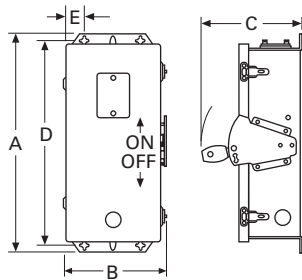
NEMA 12 Dustproof**Notes**

- ① Maximum wire size: 4/0.
- ② Maximum wire size: 500 kcmil.

1.2

Switching Devices

Enclosed Circuit Breakers

1

Approximate Dimensions in Inches (mm)

NEMA 3R Rainproof

Frame	Maximum Amperes	A	B	C	D	E	Approximate Weight in Lbs (kg)
G, F ^①	100	19.91 (505.7)	9.16 (232.7)	9.31 (236.5)	18.53 (470.7)	1.70 (43.2) ^②	16 (7)
Earth leakage	100	19.91 (505.7)	9.19 (232.7)	9.31 (236.5)	18.53 (470.7)	1.70 (43.2)	19 (9)
FBP, FCL	100	25.66 (651.8)	9.16 (232.7)	9.31 (236.5)	24.28 (616.7)	1.70 (43.2)	19 (9)
F ^③	225	25.66 (651.8)	9.16 (232.7)	9.31 (236.5)	24.28 (616.7)	1.70 (43.2)	19 (9)
J	250	37.50 (952.5)	11.88 (301.8)	10.22 (259.6)	35.77 (908.6)	1.94 (49.3)	37 (17)
K ^④	400	41.69 (1058.9)	12.31 (312.7)	14.06 (357.1)	39.94 (1014.5)	1.97 (50.0)	58 (26)
LG	600	53.37 (1355.6)	23.06 (585.7)	14.10 (358.1)	51.63 (1311.4)	1.94 (49.3)	94 (43)
Earth leakage	600	53.37 (1355.6)	23.06 (585.7)	14.10 (358.1)	51.63 (1311.4)	1.94 (49.3)	94 (43)
L	600	48.31 (1227.1)	15.56 (395.2)	15.50 (393.7)	46.56 (1182.6)	1.92 (48.8)	84 (38)
M, N	1200	63.59 (1615.2)	22.63 (574.8)	17.63 (447.8)	61.84 (1570.7)	1.97 (50.0)	175 (80)
M, N ^⑤	400–1200	71.06 (1804.9)	32.40 (823.0)	17.65 (448.3)	69.32 (1760.7)	8.04 (204.2)	214 (97)

NEMA 3R Rainproof[®]

Catalog Number RCNDN1200

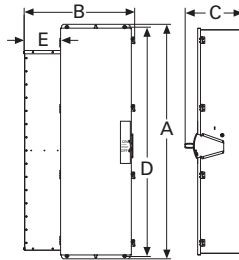
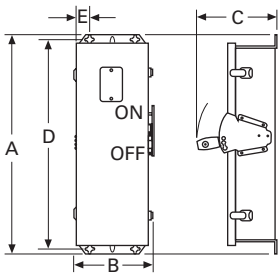

NEMA 3R Rainproof RFDN100 Series "B"

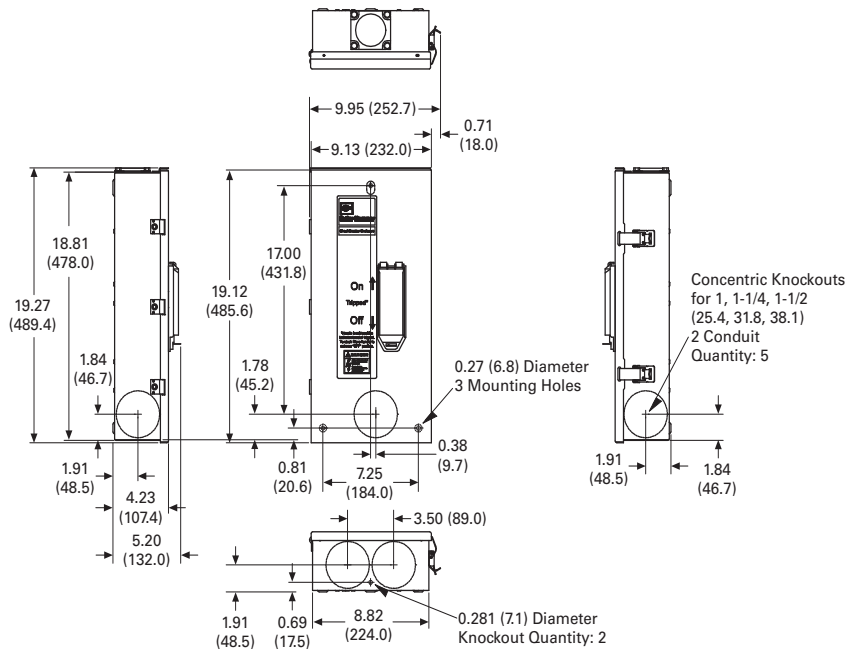

Notes

- ① RFDN100 Series "B" released 9/15/01.
- ② Single centered mounting hole provided on RFDN100, Series "B."
- ③ Maximum wire size: 4/0.
- ④ Maximum wire size: 500 kcmil.
- ⑤ 100% rated breakers.
- ⑥ All NEMA 3R except RFDN100.

Approximate Dimensions in Inches (mm)

NEMA 4/4X, 5, 7/9

Note: Not to be used for construction purposes unless approved.

NEMA 4/4X, 5 Stainless Steel

Frame	Maximum Amperes	A	B	C	D	E	Approximate Weight in Lbs (kg)
G, F	100	19.91 (505.7)	8.84 (224.5)	9.31 (236.5)	18.53 (470.7)	1.70 (43.2)	16 (7)
Earth leakage	100	19.91 (505.7)	8.84 (224.5)	9.31 (236.5)	18.53 (470.7)	1.70 (43.2)	20 (9)
FBP, FCL	100	25.66 (651.8)	8.84 (224.5)	9.31 (236.5)	24.28 (616.7)	1.70 (43.2)	20 (9)
F ^①	225	25.66 (651.8)	8.84 (224.5)	9.31 (236.5)	24.28 (616.7)	1.70 (43.2)	20 (9)
J	250	37.50 (952.5)	11.56 (293.6)	10.22 (259.6)	35.77 (908.6)	1.94 (49.3)	39 (18)
K ^②	400	41.69 (1058.9)	11.75 (298.5)	14.06 (357.1)	39.94 (1014.5)	1.97 (50.0)	60 (27)
LG	600	53.38 (1355.9)	23.06 (585.7)	14.11 (358.4)	51.64 (1311.7)	1.94 (49.3)	96 (44)
Earth leakage	600	53.38 (1355.9)	23.06 (585.7)	14.11 (358.4)	51.64 (1311.7)	1.94 (49.3)	96 (44)
L	600	48.31 (1227.1)	14.91 (378.7)	15.50 (393.7)	46.56 (1182.6)	1.92 (48.8)	88 (40)
M, N	1200	63.59 (1615.2)	22.00 (558.8)	17.63 (447.8)	61.84 (1570.7)	1.97 (50.0)	185 (84)

NEMA 4/4X, 5 Stainless Steel

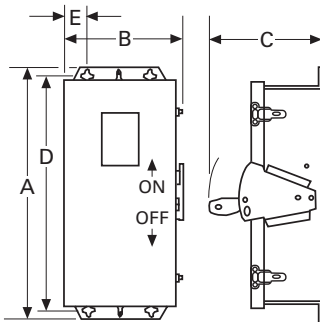

Notes

- ① Maximum wire size: 4/0.
- ② Maximum wire size: 500 kcmil.

1.2

Switching Devices

Enclosed Circuit Breakers

1

Approximate Dimensions in Inches (mm)

NEMA 7/9 Cast Aluminum with Weather-Resistant Seals—15–250A

Breaker Frame	Breaker Size Amperes	Number of Outlets	Mounting ^①			Inside ^①			Outside ^①			K ^① Dim	Standard Conduit Size ^①	Approximate Weight in Lbs (kg)
			A	B	J	C	D	E	F	G	H			
F XFDN050B	15–50	4	5.50 (139.7)	13.13 (333.5)	14.13 (358.9)	6.13 (155.7)	10.75 (273.1)	5.25 (133.4)	10.63 (270.0)	15.25 (387.4)	8.88 (225.6)	2.00 (50.8)	1.50 (38.1)	38 (17)
F ^① XFDN100B	60–100	4	6.00 (152.4)	18.00 (457.2)	19.00 (482.6)	6.50 (165.1)	16.00 (406.4)	5.50 (139.7)	11.00 (279.4)	20.50 (520.7)	9.00 (228.6)	2.31 (58.7)	2.00 (50.8)	57 (26)
F ^① XFDN225B	125–225	4	10.25 (260.4)	22.63 (574.8)	—	11.38 (289.1)	20.00 (508.0)	6.38 (162.1)	16.38 (416.1)	25.13 (638.3)	9.63 (244.6)	3.50 (88.9)	2.50 (63.5)	104 (47)
J XJDN225B	70–225	4	8.50 (215.9)	27.13 (689.1)	—	11.25 (285.8)	29.88 (759.0)	7.38 (187.5)	16.00 (406.4)	29.50 (749.3)	12.31 (312.7)	4.00 (101.6)	3.00 (76.2)	145 (66)
J XJDN250B	250	4	9.50 (241.3)	27.25 (692.2)	—	11.25 (285.8)	29.88 (759.0)	8.06 (204.7)	16.38 (416.1)	35.00 (889.0)	12.38 (314.5)	4.19 (106.4)	4.00 (101.6)	170 (77)

NEMA 7/9 Cast Aluminum with Weather-Resistant Seals—Dual Three- and Four-Point Mounting Available as Standard on F-Frame 100A and Below

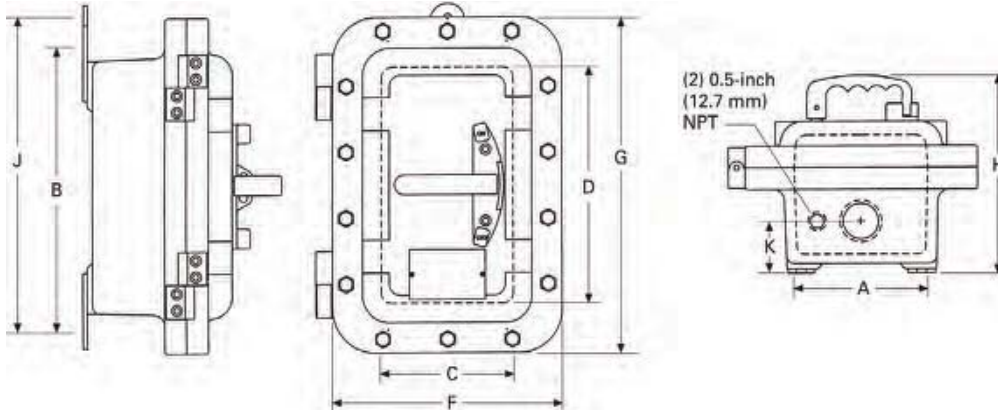

Note

^① Maximum wire size: 4/0.

Approximate Dimensions in Inches (mm)

7/9 Cast Aluminum with Weather-Resistant Seals—400–1200A

Breaker Frame	Breaker Size Amperes	Overall Enclosure				Enclosure Mounting			Conduit		Hinged Cover	Standard Conduit		Weight Lbs (kg)
		A	B	C	D	E	F	G	H	I	J	Size	Location	
K ^① XKDN400B	400	35.00 (889.0)	16.38 (416.1)	12.63 (320.8)	7.13 (181.1)	9.50 (241.3)	27.25 (692.2)	0.50 (12.7)	3.00 (76.2)	4.19 (106.4)	5.50 (139.7)	4.00 (101.6)	1, 3 and 6, 8	170 (77)
L XLDN600B	600	37.88 (962.2)	23.88 (606.6)	14.25 (362.0)	8.25 (209.6)	16.00 (406.4)	45.38 (1152.7)	0.50 (12.7)	4.00 (101.6)	5.00 (127.0)	6.00 (152.4)	4.00 (101.6)	1, 3 and 6, 8	419 (190)
M XMCM800B	800	47.88 (1216.2)	13.63 (346.2)	12.81 (325.4)	6.81 (173.0)	16.13 (409.7)	40.75 (1035.1)	0.50 (12.7)	4.00 (101.6)	4.00 (101.6)	6.00 (152.4)	4.00 (101.6)	1, 3 and 6, 8	228 (104)
N ^② XNDN1200B	1200	64.00 (1625.6)	26.00 (660.4)	21.38 (543.1)	14.38 (365.3)	27.56 (700.0)	38.63 (981.2)	0.50 (12.7)	6.50 (165.1)	4.38 (111.3)	7.00 (177.8)	4.00 (101.6)	1, 3 and 6, 8	567 (257)

NEMA 7/9 Cast Aluminum with Weather-Resistant Seals

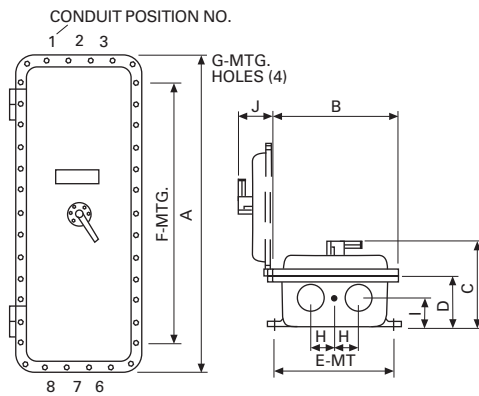

Conduit Openings

Refer to outline dimensions for size and location of standard conduit openings. In addition, 1/2-inch (12.7 mm) openings are drilled and tapped for breather and drain. Unless ordered with breather and drain, these openings are plugged. Refer to Eaton for price of breather and drain.

Notes

- ① Maximum wire size: 500 kcmil.
- ② Power cables must enter and leave from opposite ends (through-feed).

Enclosed Rotary Disconnects



Product Overview

Provide users with the ability to lock directly wired motor loads in the OFF position to comply with OSHA lockout/tagout regulations. Also for machine applications that require compact, economical disconnect switches.

Enclosed rotary disconnect switches allow safe control and safe disconnect of any motor application.

Features, Benefits and Functions

- Padlockable in the OFF position (up to three padlocks) to meet OSHA lockout requirements
- Available in 16–80A ratings
- 600 Vac, three- and four-pole non-fusible device
- Rated for making and breaking loads
- Accepts auxiliary contacts; capability to signal PLC controllers
- Ground lug connection provided
- Possibility of adding one power pole and one auxiliary contact
- NEMA® Type 1, 3R, 12, 4, 4X

Open rotary disconnects can be found in Volume 5, Tab 3 titled: NEMA Manual Starters.

Contents

Description

	<i>Page</i>
Product Overview	V2-T1-132
Features, Benefits and Functions	V2-T1-132
Standards and Certifications	V2-T1-132
Product Selection	V2-T1-133
Dimensions	V2-T1-134

Standards and Certifications

- Meets NEC® Article 430 requirements for a separate disconnect means within sight of all motor loads
- UL® listed under Section 508
- UL listed File No. E165150
- CSA® listed under 22.2 No. 14, File 162136



Product Selection

Enclosed Rotary Non-Fusible

Ampere Rating	Maximum Horsepower Ratings				NEMA 1 ^① Enclosure Indoor Catalog Number	NEMA 12 ^{①②} Enclosure Dust-Tight/ Rainproof Catalog Number	NEMA 4X ^① Enclosure Corrosion-Resistant, Stainless Steel Catalog Number	NEMA 4X ^① Enclosure Corrosion-Resistant, Non-Metallic Catalog Number	NEMA 4X Enclosure Polycarbonate- Non-Metallic Catalog Number
	Three-Phase AC								
	208V	240V	480V	600V					
Three-Pole, 600 Vac									
16	3	5	10	10	ER53016UG	ER53016UD	ER53016UW	ER53016UX	—
25	7-1/2	7-1/2	15	20	ER53025UG	ER53025UD	ER53025UW	ER53025UX	—
30	7-1/2	7-1/2	15	20	ER53030UG	ER53030UD	ER53030UW	ER53030UX	ER53030UPGB ^{③④}
40	7-1/2	7-1/2	20	25	ER53040UG	ER53040UD	ER53040UW	ER53040UX	—
60	15	15	30	30	ER53060UG	ER53060UD	ER53060UW	ER53060UX	ER53060UPGB ^{③④}
80	15	20	40	40	ER53080UG	ER53080UD	ER53080UW	ER53080UX	—
Four-Pole, 600 Vac									
16	3	5	10	10	ER54016UG	ER54016UD	ER54016UW	ER54016UX	—
25	7-1/2	7-1/2	15	20	ER54025UG	ER54025UD	ER54025UW	ER54025UX	—
30	7-1/2	7-1/2	20	25	ER54030UG	ER54030UD	ER54030UW	ER54030UX	—
40	7-1/2	7-1/2	20	25	ER54040UG	ER54040UD	ER54040UW	ER54040UX	—

Accessories for Enclosed Rotary Disconnects^{⑤⑥}

Disconnect Ampere Rating	Switched Fourth Pole	Unswitched Neutral Pole	Auxiliary Contacts (Choose one)	Terminal Shrouds
16	S4PR516	UNMR5A	1NO + 1NC AC1NONC	Single-pole TS1R5A
25	S4PR525		2NO AC2NO	Three-pole TS3R5A
30	S4PR530			UNMR5B
40	S4PR540	Three-pole TS3R5B		
60	S4PR560			
80	S4PR580			

Notes

- ① For CSA listed switches, add prefix letter "C" to the front of the catalog number.
- ② NEMA Type 12 enclosures (16–80A) can be field modified to meet NEMA Type 3R rainproof requirements when a factory-provided drain hole is opened.
- ③ GB suffix = Gray cover, Black handle. GR suffix = Gray cover, Red handle. YR suffix = Yellow cover, Red handle.
- ④ cULus only.
- ⑤ Ordered and shipped as separate components—not integral to enclosed device.
- ⑥ Enclosed disconnects can accept one power pole, neutral or up to two auxiliary contacts (one mounted on either side of switch).

Contact the Safety Switch Flex Center (1-888-329-9272 or FlexSwitches@eaton.com) for factory-installed accessories or other special modifications.

1.3

Switching Devices

Enclosed Rotary Disconnects

1

Dimensions

Approximate Dimensions in Inches (mm)

NEMA Type 1 (16–40A)

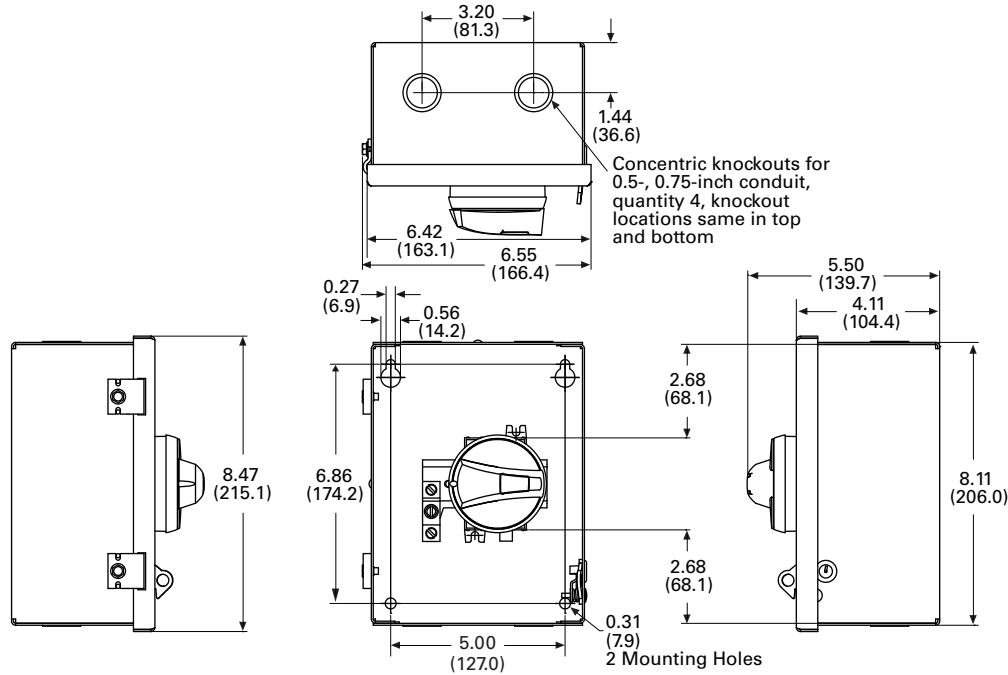

Note:

Wire range of switch lugs for 16–25A is #6–#10 copper, and for 30–40A is #8–#14.
Wire range of ground lugs is #2–#14 copper or aluminum.

NEMA Type 1 (60–80A)

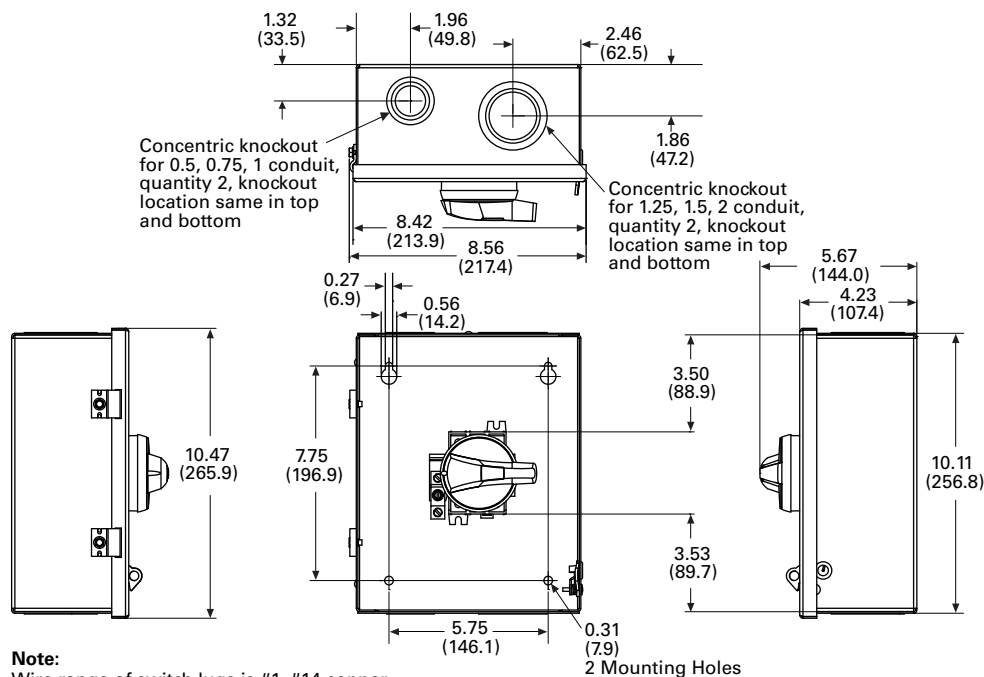

Note:

Wire range of switch lugs is #1–#14 copper.
Wire range of ground lugs is #2–#14 copper or aluminum.

Approximate Dimensions in Inches (mm)

NEMA Type 12/3R (16–40A)

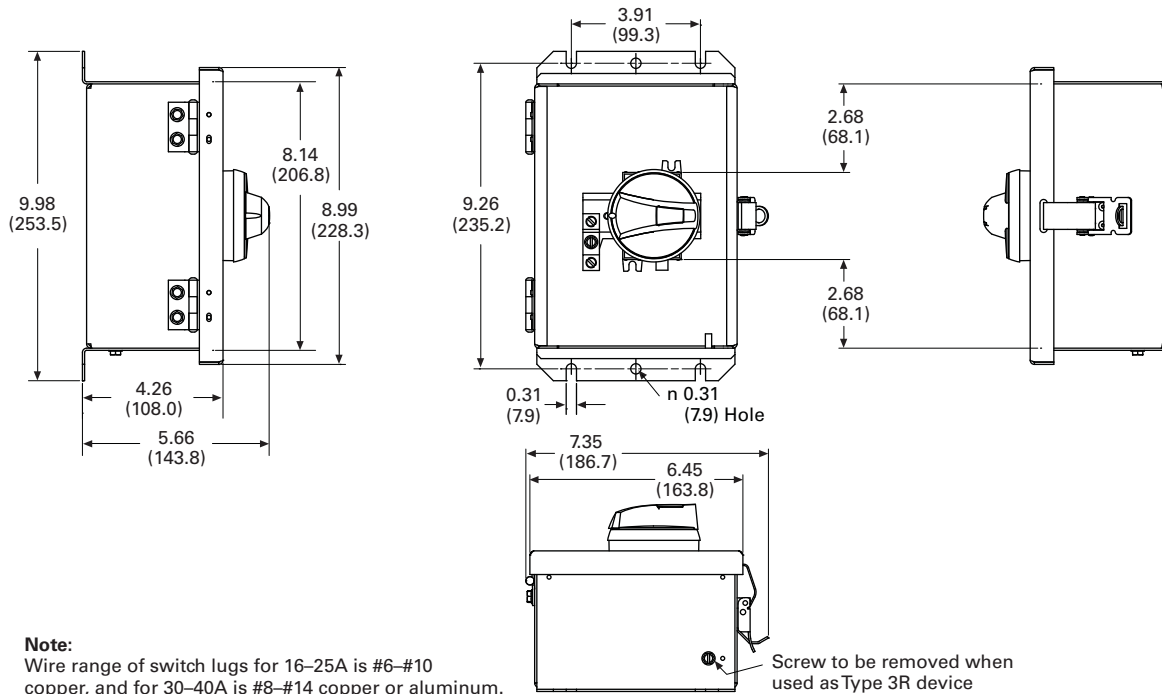

NEMA Type 12/3R (60–80A)

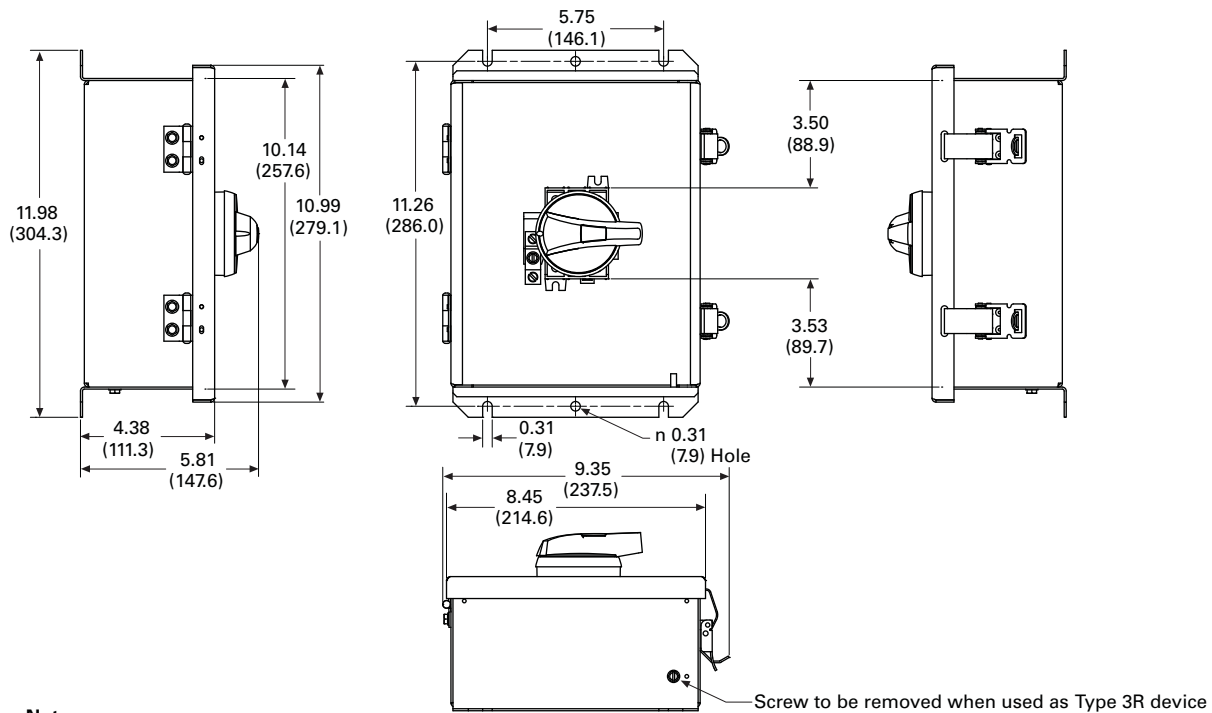

1.3

Switching Devices

Enclosed Rotary Disconnects

1

Approximate Dimensions in Inches (mm)

NEMA Type 4X Stainless (16–40A)

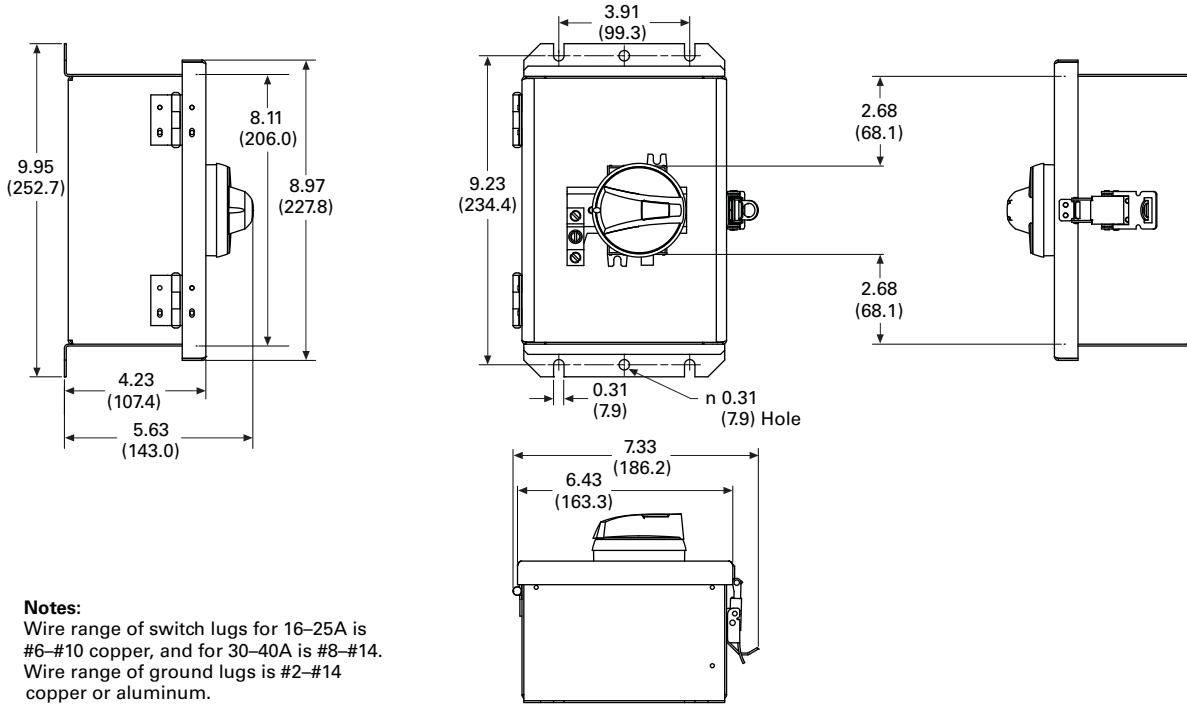

NEMA Type 4X Stainless (60–80A)

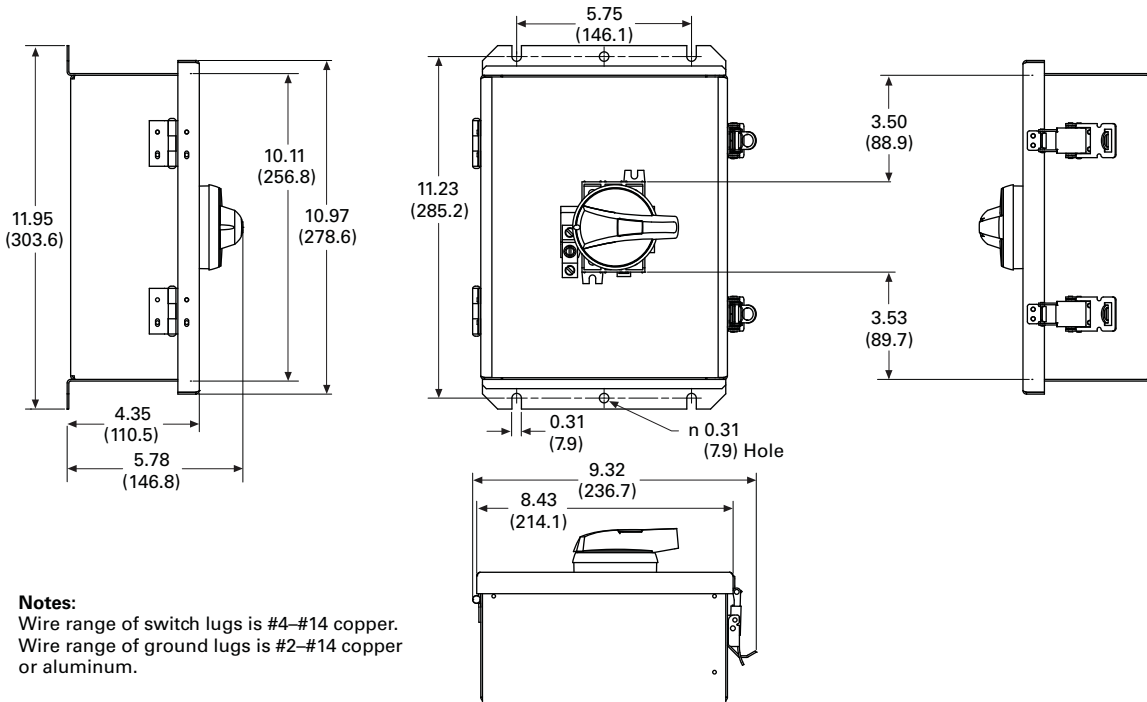

Approximate Dimensions in Inches (mm)

NEMA Type 4X Thermoset Polyester (16–40A)

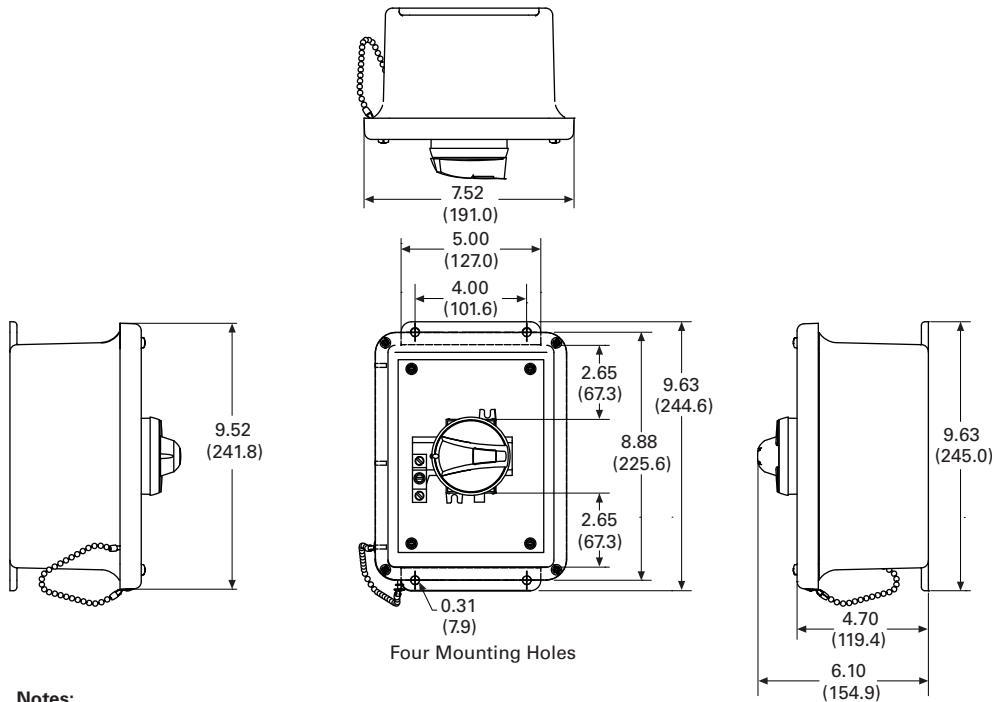

Notes:

Wire range of switch lugs for 16–25A is #6–#10 copper, and for 30–40A is #8–#14.
Wire range of ground lugs is #2–#14 copper or aluminum.

NEMA Type 4X Thermoset Polyester (60–80A)

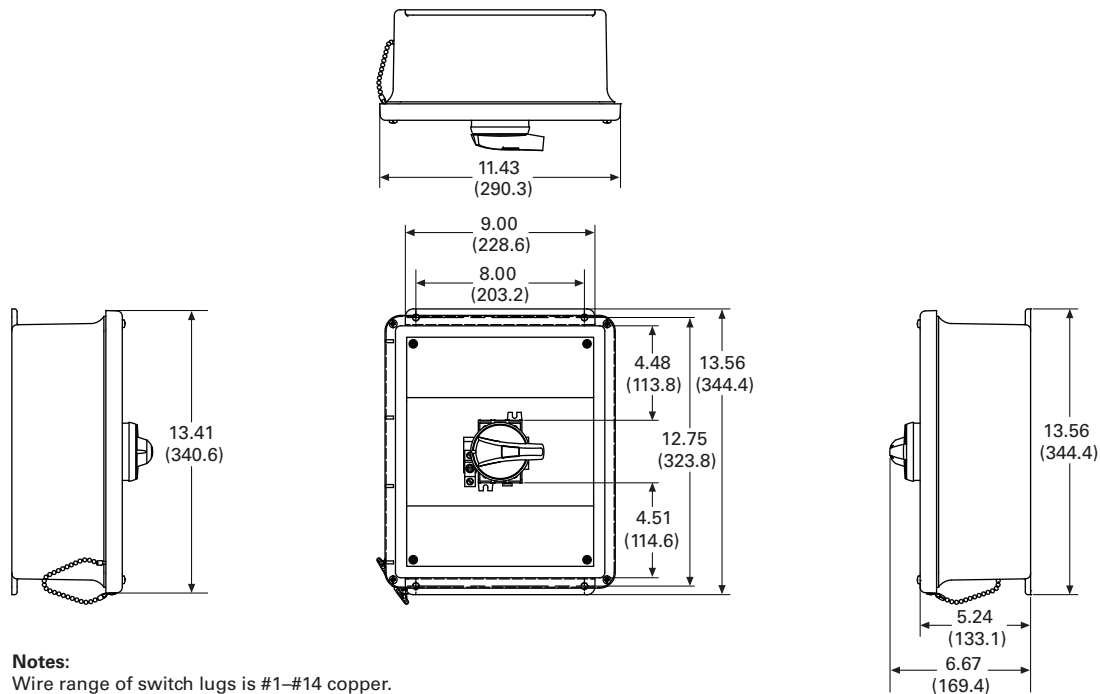

Notes:

Wire range of switch lugs is #1–#14 copper.
Wire range of ground lugs is #2–#14 copper or aluminum.

1.3

Switching Devices

Enclosed Rotary Disconnects

1

Approximate Dimensions in Inches (mm)

NEMA Type 4X—Polycarbonate (30A)

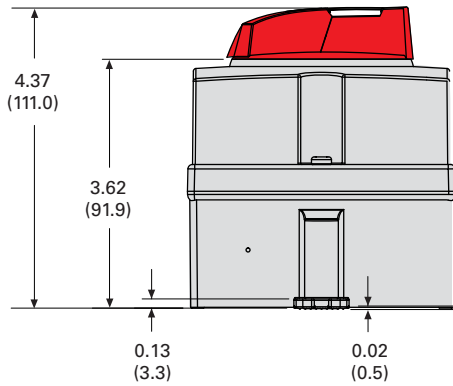
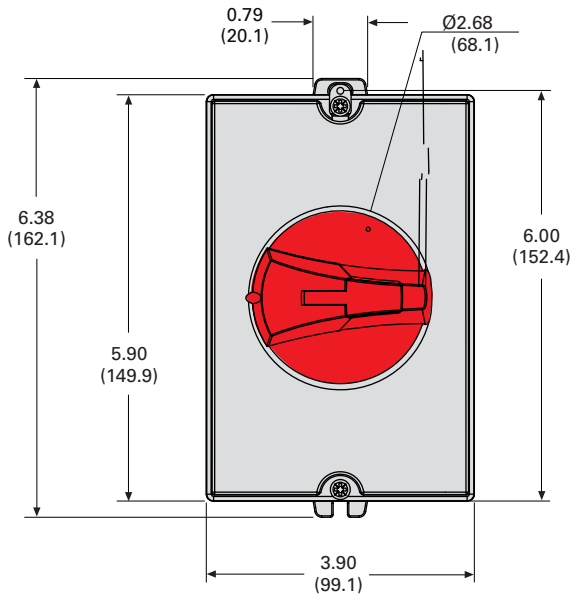

NEMA Type 4X—Polycarbonate (60A)

